

Insight standard field electrical connections are at the top left of the merchandiser

DOE 2017
Energy Efficiency
Compliant

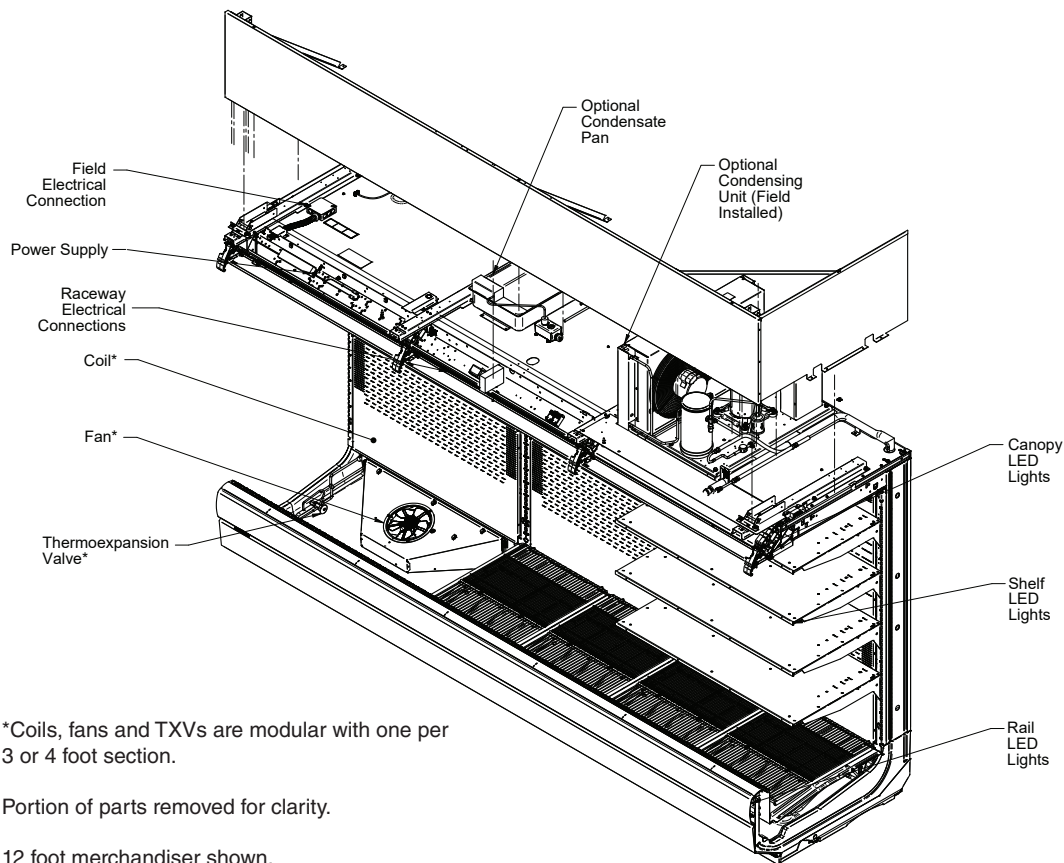

*Coils, fans and TXVs are modular with one per 3 or 4 foot section.

Portion of parts removed for clarity.

12 foot merchandiser shown.

NSF Certification

This merchandiser model is manufactured to meet NSF/ANSI (National Sanitation Foundation) Standard #7 requirements for construction, materials and cleanability.

| | | | |
|--------------------------------|--------|---|---------|
| Performance Data | Page 2 | Estimated Shipping Weights | Page 6 |
| Product Data (AHRI Statistics) | Page 2 | Shelf Options | Page 6 |
| Cross Section | Page 3 | Wiring Diagrams | Page 7 |
| Plan View | Page 4 | Computing Refrigeration and Electrical Load | Page 10 |
| Electrical Loads | Page 5 | QR Code for Parts and Product Information | Page 10 |
| | | Revision History | Page 10 |

Data sheet-Insight IDF5SL

We reserve the right to change or revise specifications and product design in connection with any feature of our products. Such changes do not entitle the buyer to corresponding changes, improvements, additions or replacements for equipment previously sold or shipped.

Insight IDF5SL
Dairy / Deli / Beverage /
Produce / Meat

Refrigeration Data ¹

| IDF5SL | | Optimal Shelf Life | | | | Energy Comparison |
|------------------------------|---|-------------------------------------|----------------------|------------------------------------|-------------------|--|
| Application | | Dairy/Deli/ Beverage/ Produce | Convertible/ Meat | NSF Type 2 Ambient ³ | Pegs ⁴ | AHRI 1200 Rating Point ⁵ |
| Unlit Shelves | Discharge Air °F (°C) | 32 (0) | 31 (-0.55) | 30 (-1.11) | 30 (-1.11) | 35 (1.66) |
| | Average Evaporator °F (°C) ² | 28 (-2.22) | 27 (-2.77) | 26 (-3.33) | 26 (-3.33) | 31 (-1.1) |
| | Parallel Btu/hr/ft (Watts/m) ⁶ | 1020 (981) | 1120 (1077) | 1295 (1245) | 1245 (1197) | 955 (918) |
| | Conventional Btu/hr/ft (Watts/m) ⁶ | 1115 (1072) | 1220 (1173) | 1410 (1356) | 1360 (1308) | 1040 (1000) |
| Lit Shelves | Discharge Air °F (°C) | 31 (-0.55) | 30 (-1.11) | 29 (-1.66) | -- | 34 (1.11) |
| | Average Evaporator °F (°C) ² | 27 (-2.77) | 26 (-3.33) | 25 (-3.88) | -- | 30 (-1.11) |
| | Parallel Btu/hr/ft (Watts/m) ^{6,7} | 1040 (1000) | 1130 (1087) | 1320 (1269) | -- | 965 (928) |
| | Conventional Btu/hr/ft (Watts/m) ^{6,7} | 1135 (1091) | 1230 (1183) | 1440 (1385) | -- | 1055 (1014) |
| Fan Speed⁸ | IDF5SL6 (8.25") | 1300 | 1500 ⁸ | 1500 ⁸ | 1300 | 1300 |
| | IDF5SL4, 8, 12 (8.25") | 1300 | 1500 ⁸ | 1500 ⁸ | 1300 | 1300 |

Notes:

- All data based on store temperature and humidity that does not exceed NSF Type 1 ambient conditions of 75°F and 55% relative humidity except where noted.
- Average evaporator temperature shown. Use dew point for high glide refrigerants for unit sizing. Care should be taken to use the dew point in PT tables for measuring and adjusting superheat. Adjust evaporator pressure as needed to maintain discharge air temperature shown.
- Data for operation in NSF Type 2 ambient of 80°F and 55% relative humidity.
- Hussmann Peg Shelves for Dairy/Deli applications only.
- AHRI 1200 Rating Point for energy consumption comparison only.
- Subtract 60 Btu/hr/ft (57.7 Watts/m) for front glass (on applicable models).
- Add 10 Btu/hr/ft (9.6 Watts/m) per shelf row for LED shelf light fixtures.
- Some lengths and/or applications require optional fan speed control kits applied by the Hussmann Product Configurator.
- Reduce refrigeration load by 15% if fitted with CaseShieldPTM.

Defrost Data

Frequency (hours between defrost) 4

OFFTIME IDF5SL
Time (minutes) 20

ELECTRIC OR GAS Not Available

Defrost Water ¹⁰ 8.1 lb/ft/day
(12 kg/m)

¹⁰ (± 15% based on case configuration and product loading).

Conventional Controls

IDF5SL
Low Pressure Backup Control CI/CO ¹¹
20°F / 10°F
-6.67°C / -12.2°C

Indoor Unit Only, Pressure Defrost Termination ¹¹
48°F (8.89°C)

¹¹ Use a Temperature Pressure Chart to determine PSIG conversions.

Product Data

Gross Refrigerated Volume ¹² (Cu Ft/Ft) 11.5 ft³/ft (1.07 m³/m)

AHRI Total Display Area ¹³ (Sq Ft/Ft) 4.56 ft²/ft (1.39 m²/m)

Shelf Area ¹⁴ (Sq Ft/Ft) 9.85 ft²/ft (3.00 m²/m)

¹² AHRI Gross Refrigerated Volume: Refrigerated Volume/Unit of Length, ft³/ft [m³/m]

¹³ Computed using AHRI 1200 standard methodology: Total Display Area, ft² [m²]/Unit of Length, ft [m]

¹⁴ Shelf surface area is composed of bottom deck plus standard shelf complement for this model: (4) rows of 22-inch shelves

Refrigeration Data Continued

Total Working Refrigerant Charge ¹⁵

Air-Cooled

With Recommended Condensing Unit Installed

| | | | |
|--------------|-------------|---|---------|
| 4 ft | 5 lb, 6 oz | / | 2.45 kg |
| 6 ft | 7 lb | / | 3.18 kg |
| 8 ft | 7 lb, 6 oz | / | 3.36 kg |
| 12 ft | 8 lb, 13 oz | / | 4.00 kg |

Water-Cooled

With Recommended HMDSLMT Condensing Unit Installed

| | | | |
|--------------|-------------|---|---------|
| 4 ft | 3 lb, 10 oz | / | 1.63 kg |
| 6 ft | 3 lb, 13 oz | / | 1.73 kg |
| 8 ft | 4 lb | / | 1.82 kg |
| 12 ft | 5 lb, 2 oz | / | 2.32 kg |

¹⁵ The Total Refrigerant Charge includes the case and condensing unit. Both ship pre-charged with a portion of the total refrigerant.

Insight IDF5SL
 Dairy / Deli / Beverage /
 Produce / Meat

Insight Multideck Merchandiser, Freedom,
 5 Display Levels, Standard Bottom, Low Height Front

DOE 2017
 Energy Efficiency
 Compliant

Hussmann refrigerated merchandisers configured for sale for use in the United States meet or surpass the requirements of the DOE 2017 energy efficiency standards.

Shelf complement shown as tested:
 Four rows of 22-in. shelves spaced
 equally between bottom display pan
 and interior top panel.

**Other optional kits (top
 piping and vent fans) add to
 the overall case height.**

**A minimum 1 1/2-in. clearance
 required to remove raceway
 cover, 6 1/2-in. for full access.
 See the Installation manual
 for instructions.**

**3-in. between back to back
 cases.**

**Shown with Ellipse Option
 Canopy and Bumper.**

OPTIONAL RAIL LIGHT

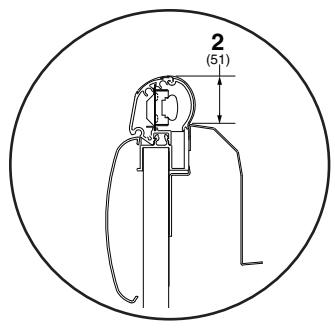

OPTIONAL GLASS FRONT

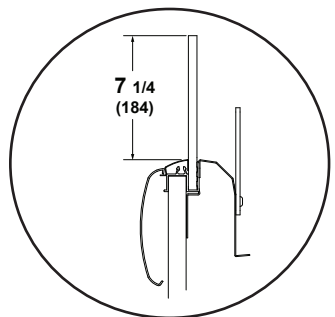

Dimensions shown as in. and (mm).

IDF5SL

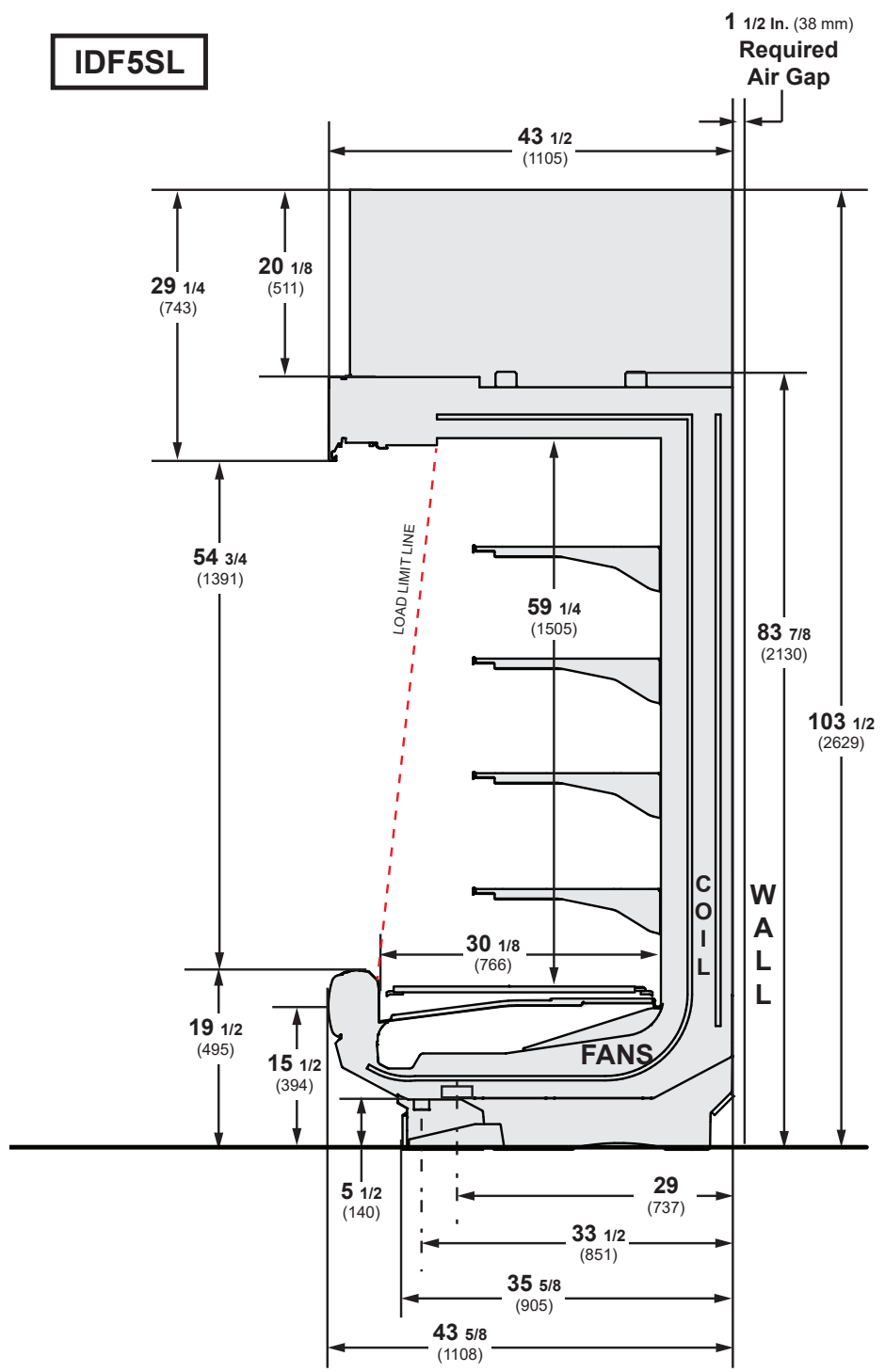

Engineering Plan View

Insight IDF5SL
Dairy / Deli / Beverage /
Produce / Meat

Dimensions shown as in. and (mm).

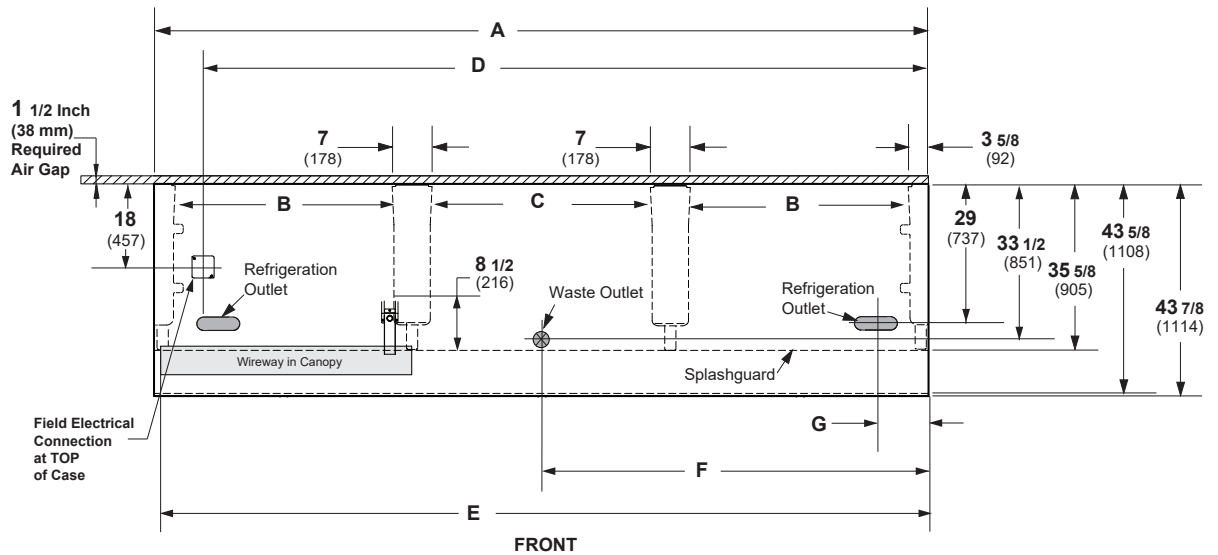

(12 Foot Model shown above)

| | 4 ft | 6 ft | 8 ft | 12 ft |
|--|---------------|---------------|---------------|----------------|
| General | | | | |
| (A) Case Length (<i>without ends or partitions</i>) (Each end and insulated partition adds 1 1/2 in. (38 mm) to case line up.) | 48 1/8 (1222) | 72 1/4 (1835) | 96 1/4 (2445) | 144 3/8 (3668) |
| Maximum O/S dimension of case back to front (<i>includes bumper</i>) | 43 5/8 (1108) | 43 5/8 (1108) | 43 5/8 (1108) | 43 5/8 (1108) |
| Back of case to front of splashguard | 35 5/8 (905) | 35 5/8 (905) | 35 5/8 (905) | 35 5/8 (905) |
| (B) Distance between edges of external legs and center legs | NA | 29 (737) | 41 (1041) | 41 (1041) |
| (C) Distance between edges of center legs | 41 1/8 (1045) | NA | NA | 41 1/8 (1045) |
| Distance between front legs and splashguard | 8 (203) | 8 (203) | 8 (203) | 8 (203) |
| Electrical Service (<i>Field Electrical Wiring Connection</i>) | | | | |
| (D) RH End of case to center of Field Electrical Wiring Connection (<i>top of case</i>) | 39 3/8 (1000) | 63 1/2 (1613) | 87 1/2 (2223) | 135 1/2 (3442) |
| Back of case to center of Field Electrical Wiring Connection | 18 (457) | 18 (457) | 18 (457) | 18 (457) |
| Length of electrical wireway | 44 5/8 (1133) | 33 1/2 (851) | 45 7/8 (1165) | 45 7/8 (1165) |
| (E) RH end of case to LH end of electrical wireway (<i>top of case</i>) | 46 1/2 (1181) | 70 1/2 (1791) | 94 1/2 (2400) | 142 5/8 (3630) |
| Waste Outlets | | | | |
| (F) RH End of case to the center of waste outlet | 24 1/8 (613) | 24 1/8 (613) | 24 1/8 (613) | 72 1/4 (1835) |
| Back O/S of case to center of waste outlet(s) | 33 1/2 (851) | 33 1/2 (851) | 33 1/2 (851) | 33 1/2 (851) |
| Schedule 40 PVC drip pipe | 1 1/4 (32) | 1 1/4 (32) | 1 1/4 (32) | 1 1/4 (32) |
| Refrigeration Outlet | | | | |
| (G) Back of case to center of refrigeration outlet | 29 (737) | 29 (737) | 29 (737) | 29 (737) |
| End of case to center of refrigeration outlet | 8 1/2 (216) | 8 1/2 (216) | 8 1/2 (216) | 8 1/2 (216) |

| |
|--|
| Insight IDF5SL Dairy / Deli / Beverage / Produce / Meat |
|--|

Electrical Data

| | | | | |
|-----------------------|-------------|-------------|-------------|--------------|
| Number of Fans | 4 ft | 6 ft | 8 ft | 12 ft |
| 8.25-in. | 1 | 2 | 2 | 3 |

| Evaporator Fan | Amperes | | | | Watts | | | |
|-------------------------------|----------------|-------------|-------------|--------------|--------------|-------------|-------------|--------------|
| | 4 ft | 6 ft | 8 ft | 12 ft | 4 ft | 6 ft | 8 ft | 12 ft |
| 120V 60Hz Energy Efficient | 0.25 | 0.50 | 0.50 | 0.75 | 16 | 32 | 32 | 48 |
| 230V 50/60Hz Energy Efficient | 0.13 | 0.26 | 0.26 | 0.39 | 16 | 32 | 32 | 48 |

| | | | | |
|---------------------------------|------|------|------|------|
| Minimum Circuit Ampacity | | | | |
| 120V 60Hz Energy Efficient | 1.30 | 2.06 | 2.61 | 3.93 |
| 230V 50/60Hz Energy Efficient | 0.68 | 1.07 | 1.36 | 2.04 |

| | | | | |
|---|-----------|-----------|-----------|-----------|
| Maximum Over Current Protection 120V | 20 | 20 | 20 | 20 |
| Maximum Over Current Protection 230V | 15 | 15 | 15 | 15 |

Lighting

ONLY LIGHTING CONFIGURATIONS THAT ARE COMPLIANT WITH THE U.S. DEPT. OF ENERGY (DOE) 2017 REGULATION ARE AVAILABLE FOR SALE FOR USE IN THE U.S.A.

| | Amperes | | | | Watts | | | |
|----------------------------|----------------|-------------|-------------|--------------|--------------|-------------|-------------|--------------|
| | 4 ft | 6 ft | 8 ft | 12 ft | 4 ft | 6 ft | 8 ft | 12 ft |
| LED LIGHTING | | | | | | | | |
| ULTRA Canopy Lights | | | | | | | | |
| 1 Row ULTRA | 0.16 | 0.26 | 0.36 | 0.54 | 19 | 31 | 43 | 64 |
| Canopy Lights | | | | | | | | |
| 1 Row | 0.16 | 0.26 | 0.32 | 0.48 | 19 | 32 | 39 | 58 |
| 1 Row HO | 0.22 | 0.33 | 0.44 | 0.66 | 27 | 40 | 53 | 79 |
| Shelf Lights | | | | | | | | |
| 1 Row of Shelves | 0.08 | 0.12 | 0.16 | 0.25 | 10 | 14 | 20 | 30 |
| 2 Rows of Shelves | 0.16 | 0.23 | 0.33 | 0.49 | 20 | 28 | 40 | 59 |
| 3 Rows of Shelves | 0.25 | 0.35 | 0.49 | 0.74 | 30 | 42 | 59 | 89 |
| 4 Rows of Shelves | 0.33 | 0.47 | 0.66 | 0.99 | 40 | 56 | 79 | 119 |
| 5 Rows of Shelves | 0.41 | 0.59 | 0.82 | 1.24 | 49 | 71 | 99 | 148 |
| 6 Rows of Shelves | 0.49 | 0.70 | 0.99 | 1.48 | 59 | 85 | 119 | 178 |
| Rail Light-1 Row | 0.08 | 0.12 | 0.16 | 0.25 | 10 | 14 | 20 | 30 |

120V Lighting Circuit Total = Standard Lighting + Total Optional Lighting + Optional Shelf Lighting

230V Lighting Circuit Total = Multiply 120V Lighting Circuit Total by 0.52

ENDS or PARTITIONS

Each standard end and each insulated partition adds 1 1/2 in. (38 mm) to case line up. Optional view end with end bumper adds 3 3/4 in. (95 mm).

PHYSICAL DATA

| | |
|---------------------------------|-------|
| Merchandiser Drip Pipe (in.) | 1 1/4 |
| Schedule 40 PVC | |
| Merchandiser Liquid Line (in.) | 3/8 |
| Merchandiser Suction Line (in.) | 5/8 |

ESTIMATED SHIPPING WEIGHT †

| Case | 4 ft | 6 ft | 8 ft | 12 ft | Solid End (each) |
|----------------|-----------|-----------|------------|------------|---------------------|
| lb (kg) | 700 (318) | 850 (386) | 1000 (454) | 1100 (499) | 80 (36) |

† Actual weights will vary according to optional kits included.

Shelf Options

Approved shelf sizes for standard (horizontal, 2-3 position brackets) displays:

- 18-inch
- 20-inch
- 22-inch
- 24-inch

Contact engineering for non-standard (4 position brackets or other) display recommendations.

Minimum number of Shelves:3

Optimal number of Shelves:4

Maximum number of Shelves:8

Maximum number of Lighted Shelves:6

Standard shelf complement for test purposes: (4) 22-in. shelves, evenly distributed vertically

Insight IDF5SL
 Dairy / Deli / Beverage /
 Produce / Meat

Fan Wiring
Offtime Defrost

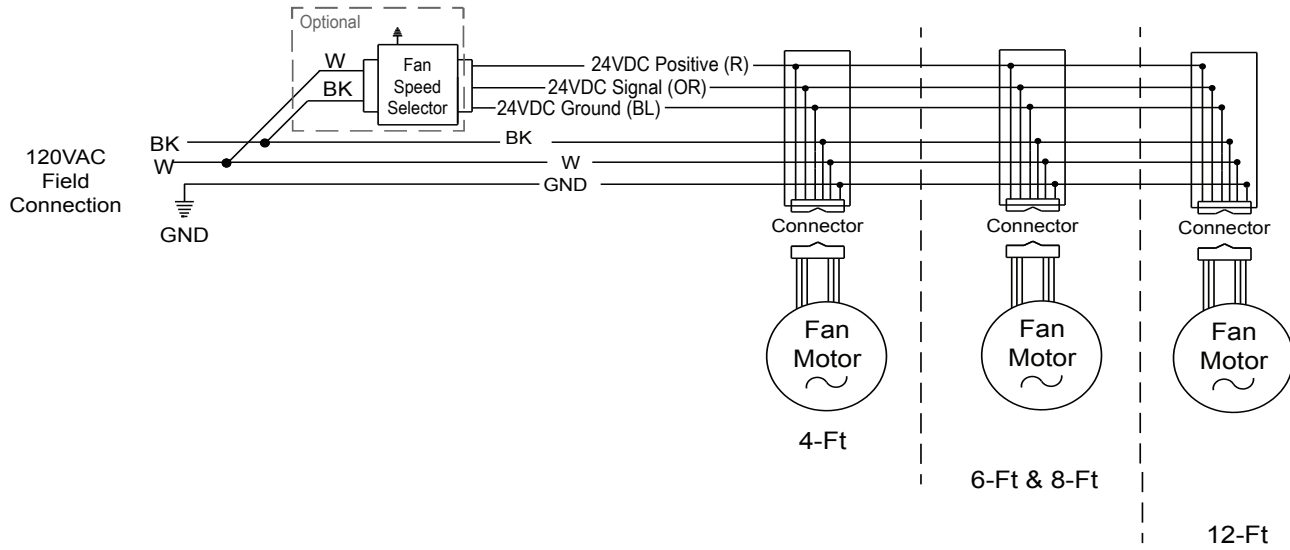

LED Canopy Light Circuits

LED Canopy Lighting - 1 Row

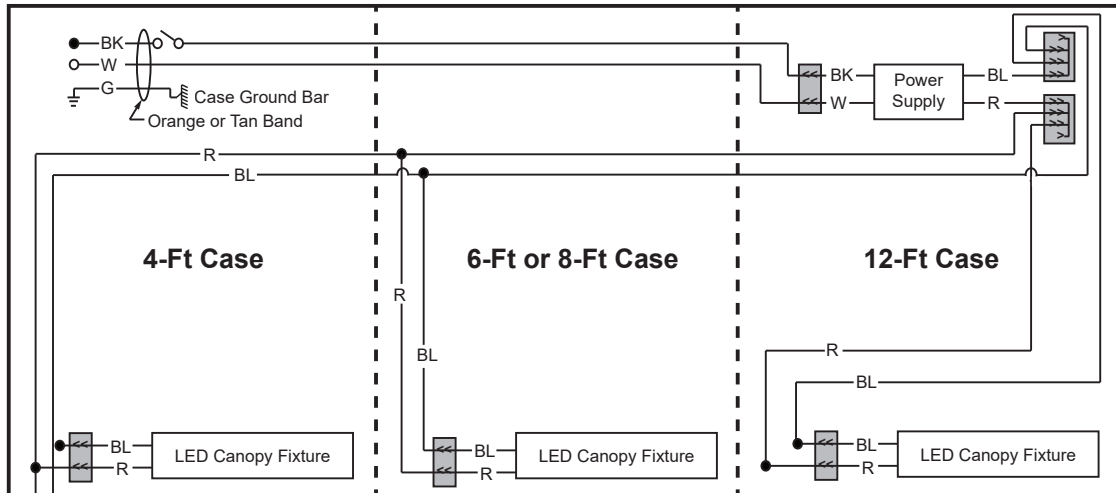

Optional Lighting - LED Rail - 1 Row

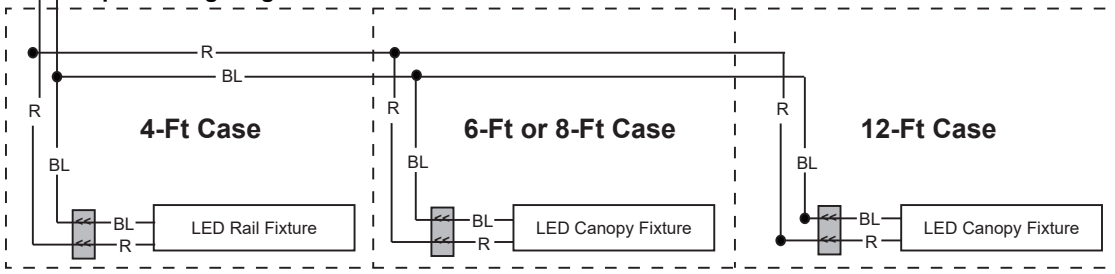

WARNING

All components must have mechanical ground, and the merchandiser must be grounded.

R = Red Y = Yellow G = Green BL = Blue BK = Black W = White
 ● = 120V POWER ○ = 120V NEUTRAL ≡ = FIELD GROUND ≡≡ = CASE GROUND

Optional LED Shelf Lighting

Insight **IDF5SL**
Dairy / Deli / Beverage /
Produce / Meat

Shelf Harness and LED Light Circuits for 4 or 5 Rows of Shelves

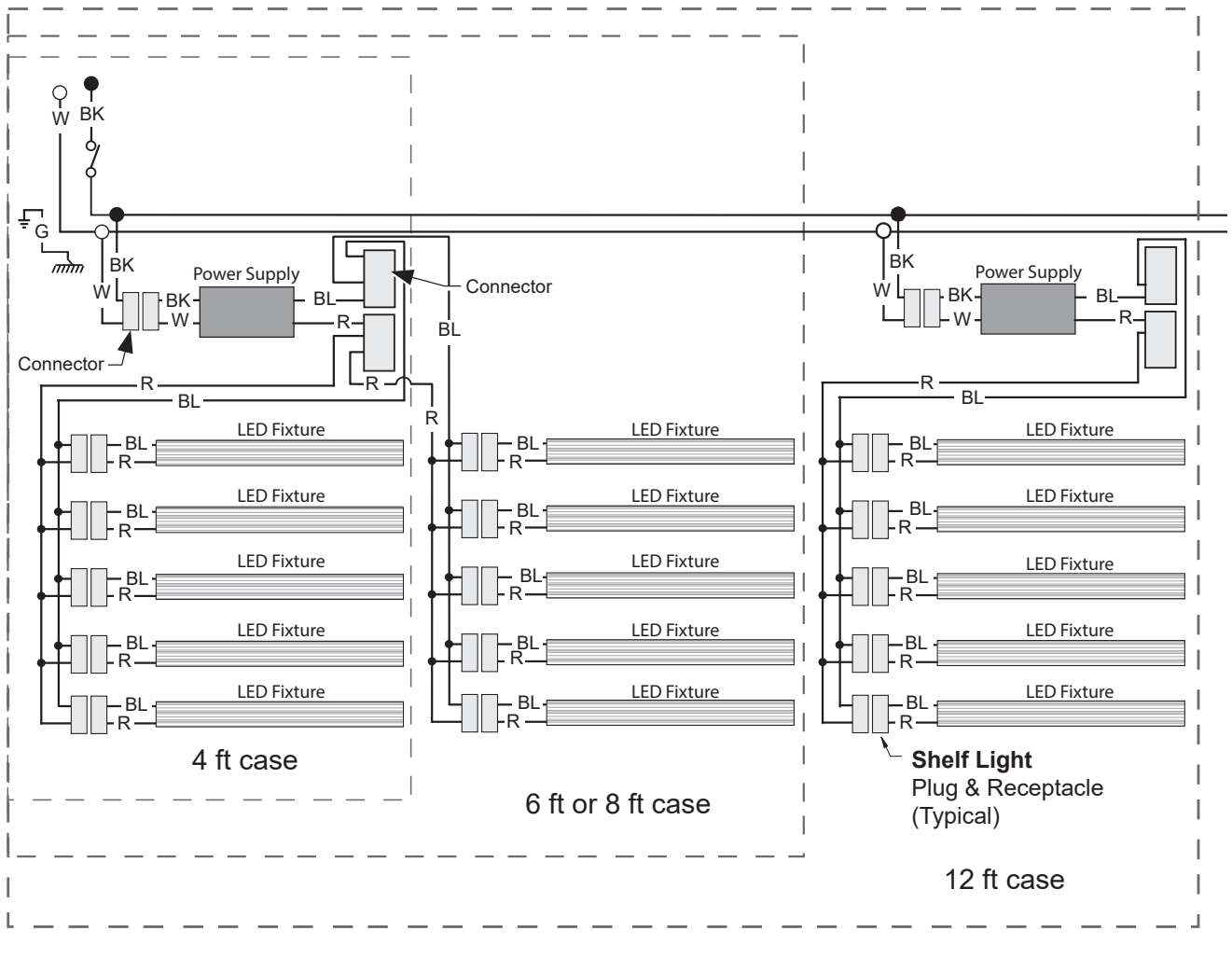

WARNING

All components must have mechanical ground, and the merchandiser must be grounded.

R = Red Y = Yellow G = Green BL = Blue BK = Black W = White
 ● = 120V POWER ○ = 120V NEUTRAL ⊥ = FIELD GROUND ≡ = CASE GROUND

Shelf Harness and LED Light Circuits for 6 or 7 Rows of Shelves

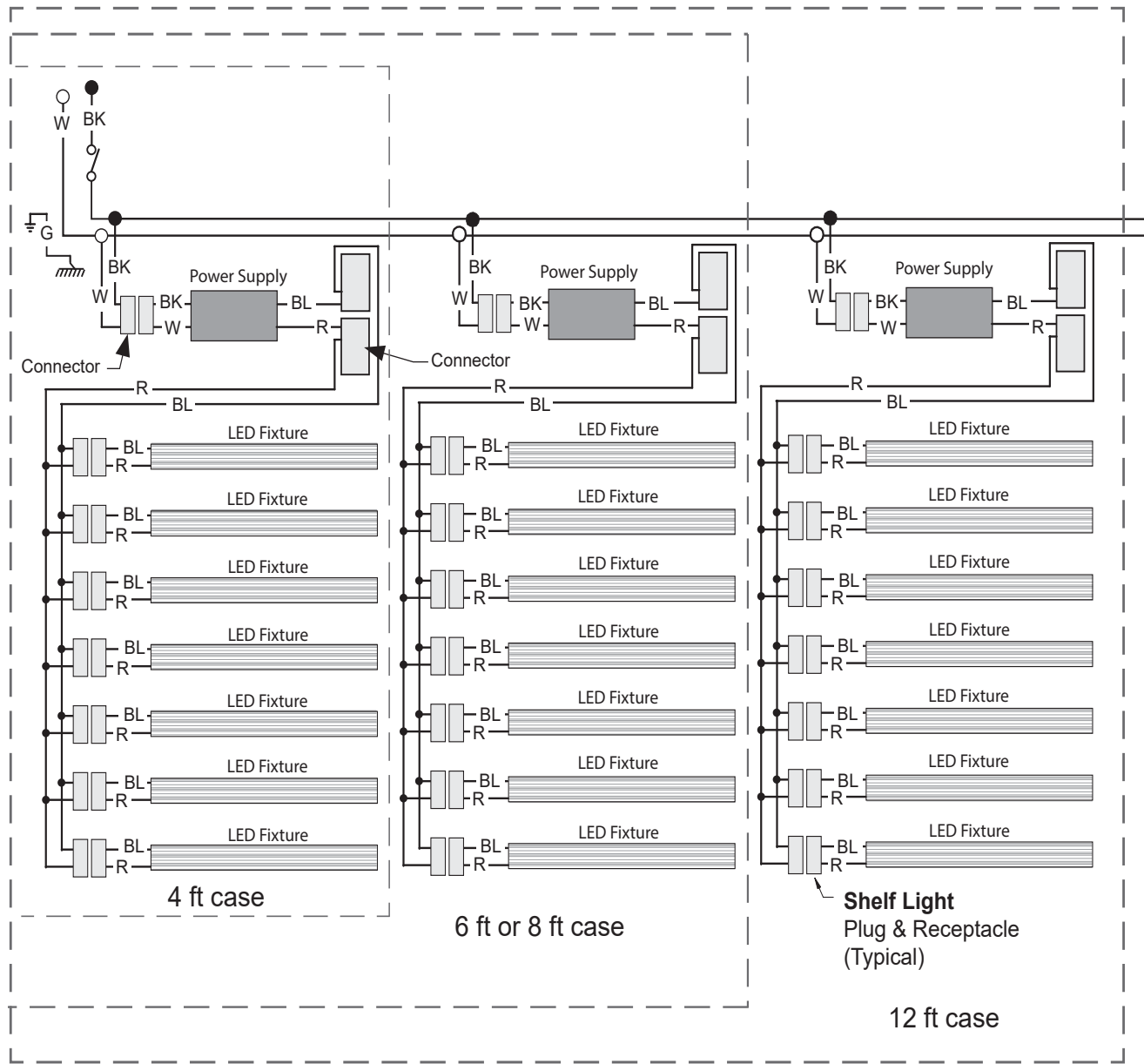

WARNING

All components must have mechanical ground, and the merchandiser must be grounded.

R = Red Y = Yellow G = Green BL = Blue BK = Black W = White
 ● = 120V POWER ○ = 120V NEUTRAL ⊥ = FIELD GROUND mm = CASE GROUND

Estimating Refrigeration and Electrical Load (for comparison purposes only)

Case Btu

To determine Btu for a case, refer to the performance data chart on page 2. Select lit or unlit shelves, then select the type of remote refrigeration system (parallel or conventional), which will give Btu/hr/ft. Multiply this number by the length of the case to determine Btu per hour. Add 10 BTU per foot per hour for each row of LED shelf lights.

Case Electrical

Refer to store legend to determine number of circuits. Lighting should be specified in store legend.

Fan electrical load for a case is computed by selecting the case length and fan voltage on page 6. For example, a 12 ft case uses 3 fans. The store legend specifies fans on a 230V circuit. In this instance, fans use 0.39 Amps and the MCA is 0.59. When applied, ambient fans, anti-sweat heaters, controllers, etc. must be included in the MCA. Include lights in the MCA if lights are on same circuit.

Lights may be on a separate circuit. To estimate lighting load: select case length (12 ft), canopy lighting [standard or optional] (here 0.70 for standard), and shelf or rail lighting [maximum for which case is wired] (1.48 for six shelves); then add together $[0.48 + 1.48 = 1.96 \text{ amps for } 120\text{V}]$ (for 230V, multiply $1.96 * 0.52 = 1.02$).

Line Sizing — Refer to store legend.

Hussmann Line Sizing Charts are engineered for use with Hussmann refrigeration equipment.



Scan the QR code with your mobile device to access additional product information or order parts.

Parts may also be ordered at:

parts.hussmann.com

Call toll free: 1.855.487.7778

Revision History

Revision A: September 2022: Original Issue