

Insight®

WARNINGS:

If the information in these instructions are not followed exactly, a fire or explosion may result, causing property damage, personal injury or death.

Installation and service must be performed by a qualified installer or service agency.

READ THE ENTIRE MANUAL BEFORE INSTALLING OR USING THIS EQUIPMENT.

The unit uses R-290 (propane) gas as the refrigerant. R-290 (propane) is flammable and heavier than air. It collects first in low areas but can be circulated by the fans. If propane gas is present or even suspected, do not allow untrained personnel to attempt to find the cause. The propane gas used in the unit has no odor. The lack of smell does not indicate a lack of escaped gas. If a leak is detected, immediately evacuate all persons from the store, and contact the local fire department to advise them that a propane leak has occurred. Do not let any persons back into the store until the qualified service technician has arrived and that technician advises that it is safe to return to the store. No open flames, cigarettes or other possible sources of ignition should be used inside or in the vicinity of the units.

FAILURE TO ABIDE BY THIS WARNING COULD RESULT IN AN EXPLOSION, DEATH, INJURY AND PROPERTY DAMAGE.

Medium Temperature with R-290 (Propane) Refrigerant



IMPORTANT

Keep in store for future reference!

Installation & Operation Manual

Shipped With Case Data Sheets

P/N 3074287_J

May 2023

Spanish P/N 3074288

⚠ WARNING

This equipment uses a flammable refrigerant. Installation, service and repair should be done only by qualified and trained technicians in accordance with this manual.

If a leak is detected, follow store safety procedures. It is the store's responsibility to have a written safety procedure in place. The safety procedure must comply with all applicable codes such as local fire department's codes.

At minimum, the following actions are required:

- Immediately evacuate all persons from the store, and contact the local fire department to advise them that a propane leak has occurred.
- Call Hussmann and/or a qualified service agent and inform them that a propane sensor has detected the presence of propane.
- Do not let any persons back into the store until the qualified service technician has arrived and that technician advises that it is safe to return to the store.
- The propane gas used in the unit has no odor. The lack of smell does not indicate a lack of escaped gas.
- A hand-held propane leak detector ("sniffer") should be used before any repair and/or maintenance is attempted. All repair parts must be identical models to the ones they are replacing.
- No open flames, cigarettes or other possible sources of ignition should be used inside the building where the units are located until the qualified service technician and/or local fire department determines that all propane has been cleared from the area and from the refrigeration systems.

⚠ WARNING

- » Do not use mechanical devices or other means to accelerate the defrosting process.
- » Do not use electrical appliances inside the food storage compartments of the case(s).

⚠ WARNING

- » Do not remove shipping crate until the merchandiser is positioned for installation.

⚠ WARNING

- » Case ventilation openings must be clear of any obstructions. Do not damage the refrigerant circuit.



BEFORE YOU BEGIN

Read these instructions completely and carefully.



PERSONAL PROTECTION EQUIPMENT (PPE)

Personal Protection Equipment (PPE) is required whenever installing or servicing this equipment. Always wear safety glasses, gloves, protective boots or shoes, long pants, and a long-sleeve shirt.

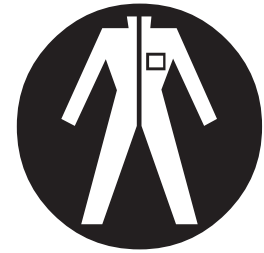
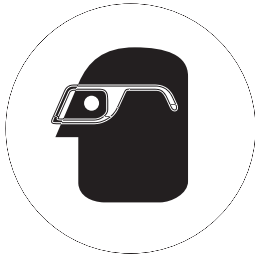

1. If the information in these instructions are not followed exactly, a fire or explosion may result, causing property damage, personal injury or death.
2. Installation and service must be performed by a qualified installer or service agency.
3. This unit is designed only for use with R-290 (propane) gas as the designated refrigerant.

THE REFRIGERANT LOOP IS SEALED. ONLY A QUALIFIED TECHNICIAN SHOULD ATTEMPT TO SERVICE!

- Propane is flammable and heavier than air.
- It collects first in the low areas but can be circulated by the fans.
- If R-290 (propane) is present or even suspected, do not allow untrained personnel to attempt to find the cause.
- The propane gas used in the unit has no odor.
- The lack of smell does not indicate a lack of escaped gas.
- If a leak is detected, immediately evacuate all persons from the store, and contact the local fire department to advise them that a propane leak has occurred.
- Do not let any persons back into the store until the qualified service technician has arrived and that technician advises that it is safe to return to the store.
- A hand-held propane leak detector (“sniffer”) shall be used before any repair and/or maintenance.
- No open flames, cigarettes or other possible sources of ignition should be used inside the building where the units are located until the qualified service technician and/or local fire department determines that all propane has been cleared from the area and from the refrigeration systems.
- Component parts are designed for propane and non-incendive and non-sparking. Component parts shall only be replaced with identical repair parts.

FAILURE TO ABIDE BY THIS WARNING COULD RESULT IN AN EXPLOSION, DEATH, INJURY AND PROPERTY DAMAGE.

ATTENTION

Merchandiser must operate for 24 hours before loading product!

Regularly check merchandiser temperatures.

Do not break the cold chain. Keep products in freezer before loading into merchandiser.

Medium temperature merchandisers are designed for loading **ONLY** pre-chilled products.

Low temperature merchandisers are designed for loading **ONLY** frozen products.



This warning does not mean that Hussmann products will cause cancer or reproductive harm, or is in violation of any product-safety standards or requirements. As clarified by the California State government, Proposition 65 can be considered more of a 'right to know' law than a pure product safety law. When used as designed, Hussmann believes that our products are not harmful. We provide the Proposition 65 warning to stay in compliance with California State law. It is your responsibility to provide accurate Proposition 65 warning labels to your customers when necessary. For more information on Proposition 65, please visit the California State government website.

A 3 inch (76 mm) space between the rear of the merchandiser and wall must be maintained for air circulation. However, in high ambient conditions, sweating may still occur. If this happens install a method of forced ventilation such as a fan ventilation kit.

IMPORTANT
KEEP IN STORE FOR FUTURE REFERENCE
Quality that sets industry standards!

12999 St. Charles Rock Road • Bridgeton, MO 63044-2483

U.S. & Canada 1-800-922-1919 • Mexico 1-800-890-2900

www.hussmann.com

© 2023 Hussmann Corporation

ANSI Z535.5 DEFINITIONS

The definitions below are used to clarify the magnitude and urgency of harm and damage, considering problems arising from misuse. Relative to their potential danger, the definitions are divided into five parts according to ANSI Z535 Series.



DANGER indicates a hazardous situation which, if not avoided, will result in death or serious injury.



WARNING indicates a hazardous situation which, if not avoided, could result in death or serious injury.



CAUTION indicates a hazardous situation which, if not avoided, could result in minor or moderate injury.



NOTICE is used to address practices not related to personal injury.



SAFETY INSTRUCTIONS (or equivalent) signs indicate specific safety-related instructions or procedures.

INSTALLATION TOOL LIST

Unloading From Trailer:

Lever Bar (also known as a Mule,
Johnson Bar, J-bar, Lever Dolly,
and pry lever)
Moving Dolly

Setting Case Line-Up:

Level, 4 ft suggested
Ratchet
1/4 in. Socket
5/16 in. Socket
1/2 in. Socket
Battery Drill/Screw Gun
Caulking Gun
10 in. Adjustable Crescent Wrench

REVISION HISTORY

REVISION J

1. Removed Page 5-4; Revised fan motor service instructions, Page 6-1, 6-2. Updated cleaning procedures, Page 5-1. Updated warning colors

REVISION H

1. Revised procedures for fan motor harness connector, Section 5 & 6.

REVISION G

1. Added Additional start up instructions and troubleshooting guidance, Page 4-2 to 4-6.

REVISION F

1. Added connection procedure for main fan motor harness connector, Page 6-4 & 6-5
2. Added serial plate note, Page 1-3

REVISION E

Added to Page 2-4 Additional Safeties; Removed info from Page 2-5; Updated CoreLink info, Page 2-6; updated with CoreLink Quick connect Guide Rev. B

REVISION D

Added Warnings to Page

REVISION C

Updated Rear Mounted Condensing Unit Drawings
Optional Drip Pipe, Connecting to CoreLink, Page 4-5 LEDs

REVISION B

Page 1-7, 1-9; Steps to Recover Refrigerant, Page 6-2

ORIGINAL ISSUE — DECEMBER 2018

WARNING

- » Excessive ambient conditions may cause condensation and therefore sweating of doors. Facility operators should monitor doors and floor conditions to ensure safety of persons.

TABLE OF CONTENTS

INSTALLATION TOOL LIST	v	Electrical Access for Sign-Ready and Fascias	2-28
ANSI Z535.5 DEFINITIONS	v	Handling Electrostatic Sensitive Devices	2-29
INSTALLATION		Installing Type II Fan Speed Selector Kit	2-30
UL Listing	1-1	Type II Fan Speed Selector Location	2-31
Federal / State Regulations	1-1	DRIP PIPING / FIT & FINISH / SPLASHGUARDS	
Location	1-1	Waste Outlet and Water Seal	3-1
Product Temperatures	1-1	Installing Drip Piping	3-2
Shipping Damage	1-2	Optional Hub Drain Drip Piping Example for	
Apparent Loss or Damage	1-2	Ultra Low Front Cases	3-4
Concealed Loss or Damage	1-2	Drain Location with Drain Extension Kit	3-5
Unloading	1-2	Final Alignment / Fit & Finish	3-7
Exterior Loading	1-2	Fascia Panel Alignment	3-8
Unloading using a Pallet Jack	1-3	Front Panel Alignment	3-9
Optional Casters and Dollies	1-3	Installing End Splashguards	3-10
Serial Plate Location	1-3	Installing Splashguard Brackets	3-12
QR Code	1-3	Installing Splashguards	3-13
Merchandisers Shipped with End Installed	1-4	Splashguard Alignment	3-14
End Shipping Braces	1-4	START-UP / OPERATION	
Shipping Rider	1-4	Start-Up Procedures and Start-Up Troubleshooting	4-1
Merchandise Leveling	1-5	12 Hour after Start-Up Checklist	4-7
Joining and Sealing Hardware	1-6	Condensing Unit Components	4-7
Apply Gasket (Multi-Deck)	1-7	Load Limits	4-8
Case Joining (Multi-Deck)	1-8	Stocking	4-8
Joining Door Cases	1-11	Shelf Maximum Weight Limits	4-9
Doors (Installing, Removing, Adjusting)	1-14	Multi-Deck Shelf Configuration	4-9
Adjusting EcoVision Doors	1-14	LED Fixtures	4-10
Adjusting Door Closing Speed	1-15	Procedure for Installing Lighted Shelves	4-11
Replacing LED Vertical Mullion Light Bars	1-15	Shelf LED Clip Installation	4-13
Sealing Lineup Joints	1-16	Product Stop Installation	4-13
Installing End Assemblies	1-17	Installing FDA/NSF Required Thermometer	4-14
Partition Hardware	1-20	MAINTENANCE	
Acrylic Partition Hardware	1-26	Identification of Case Parts	5-1
Installing Bumpers	1-28	Care & Cleaning	5-2
Installing Night Blinds	1-29	Fan Motor Harness Plug	5-4
Loading Blind Spring	1-31	Recommended Cleaning Instructions	5-5
Troubleshooting Night Blinds	1-32	Cleaning Honeycomb Assemblies	5-6
ELECTRICAL / CONTROLLER / WATER / REFRIGERATION		Bottom Liner Repair	5-7
Working with R-290 Refrigerant	2-1	Cleaning Coils	5-8
Electrical	2-2	Cleaning Stainless Steel Front Rails	5-8
Merchandise Electrical Data	2-2	Removing Scratches from Bumper	5-8
Electrical Connections	2-2	Cleaning Under Merchandisers	5-8
Field Wiring	2-2	Cleaning Mirrors	5-9
Case Electronic Controller	2-3	Removing Interior Back Panels	5-9
Controller - Common Problems	2-17	SERVICE	
Replacing Refrigeration System Components	2-19	Service Warning	6-1
Charging	2-19	Replacing Refrigeration System Components	6-2
Water (for Condensers)	2-20	Cleaning and Flushing	6-2
Inhibited Propylene Glycol System Requirements	2-21	Steps to Recover Refrigerant	6-2
Piping Requirements	2-21	Charging	6-3
Pre-Installation System Cleaning	2-22	Replacing Fan Motor	6-4
Top Mounted Water & Electrical Connections	2-23	Repairing Aluminum Coil	6-6
Refrigeration	2-25	Warranty Information	6-7
Condensing Unit Access	2-25		
Rear-Mounted Condensing Unit Views	2-26		
Identification of Wiring	2-27		
Sensor Location	2-27		

INSTALLATION

UL LISTING

These merchandisers are manufactured to meet ANSI/ UL 471 standard requirements for safety. Proper installation is required to maintain the listing.

FEDERAL / STATE REGULATION

These merchandisers at the time they are manufactured, meet all federal and state/ provincial regulations. Proper installation is required to ensure these standards are maintained. Near the serial plate, each merchandiser carries a label identifying the environment for which the merchandiser was designed for use. A Type II fan speed control kit is required for each merchandiser to operate at Type II conditions.

**ANSI/NSF-7 Type I – Display Refrigerator / Freezer
Intended for 75°F (24°C) / 55% RH Ambient Application**

**ANSI/NSF-7 Type II – Display Refrigerator / Freezer
Intended for 80°F / 55% RH Ambient Application**

**ANSI/NSF-7 – Display Refrigerator
Intended for Bulk Produce**

LOCATION

These merchandisers are designed for displaying products in air conditioned stores where temperature is maintained at or below the ANSI/ NSF-7 specified level and relative humidity is maintained at or below 55%.

Placing refrigerated merchandisers in direct sunlight, near hot tables or near other heat sources could impair their efficiency. Like other merchandisers, these are sensitive to air disturbances. Air currents passing around merchandisers will seriously impair their operation. Do NOT allow air conditioning, electric fans, open doors or windows, etc. to create air currents around the merchandisers.

PRODUCT TEMPERATURES

Product should always be maintained at proper temperature. This means that from the time the product is received, through storage, preparation and display, the temperature of the product must be controlled to maximize product life

This equipment uses a flammable refrigerant. Installation, service and repair should be done only by qualified and trained technicians in accordance with this manual.

If a leak is detected, follow store safety procedures. It is the store's responsibility to have a written safety procedure in place. The safety procedure must comply with all applicable codes such as local fire department's codes. At minimum, the following actions are required:

- Immediately evacuate all persons from the store, and contact the local fire department to advise them that a propane leak has occurred.
- Call Hussmann and/or a qualified service agent and inform them that a propane sensor has detected the presence of propane.
- Do not let any persons back into the store until the qualified service technician has arrived and that technician advises that it is safe to return to the store.
- The propane gas used in the unit has no odor. The lack of smell does not indicate a lack of escaped gas.
- A hand-held propane leak detector (“sniffer”) should be used before any repair and/or maintenance is attempted. All repair parts must be identical models to the ones they are replacing.
- No open flames, cigarettes or other possible sources of ignition should be used inside the building where the units are located until the qualified service technician and/or local fire department determines that all propane has been cleared from the area and from the refrigeration systems.

SHIPPING DAMAGE

All equipment should be thoroughly examined for shipping damage before and during unloading.

This equipment has been carefully inspected at our factory. Any claim for loss or damage must be made to the carrier. The carrier will provide any necessary inspection reports and/or claim forms.

Apparent Loss or Damage

If there is an obvious loss or damage, it must be noted on the freight bill or express receipt and signed by the carrier’s agent; otherwise, carrier may refuse claim.

Concealed Loss or Damage

When loss or damage is not apparent until after equipment is uncrated, retain all packing materials and submit a written request to the carrier for inspection, within 15 days.

UNLOADING

Improper handling may cause damage to the merchandiser when unloading. Use the shipping brace and arched pod locations to lift when unloading cases.

1. Do not drag the merchandiser out of the trailer. Use a Johnson bar (mule).
2. Do not lift the case by the liner. Lift with the metal case base, arched plastic pods or the shipping brace.
3. Do not lift from the bottom edge of the end panel.

EXTERIOR LOADING

Do NOT walk on top or inside of merchandisers or damage to the merchandisers and serious personal injury could occur. **THEY ARE NOT STRUCTURALLY DESIGNED TO SUPPORT EXCESSIVE EXTERNAL LOADING** such as the weight of a person. Use caution when working around refrigeration lines or water lines, damage to equipment and personal injury could occur.

⚠ WARNING

» If the case is to be moved using a fork lift, position the forks of the lift directly under the arched pods or shipping rails. Use extreme caution when transporting cases. Personal injury or death could result if a case falls on personnel.

⚠ WARNING

» Do not walk on case. Do not store items or flammable materials atop the case.

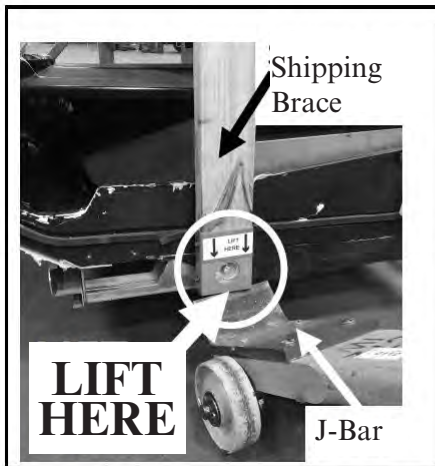

LIFT POINTS
Shipping Brace & Arched Pod

Installer lift at either of **THESE POINTS** with J-Bar when moving case.

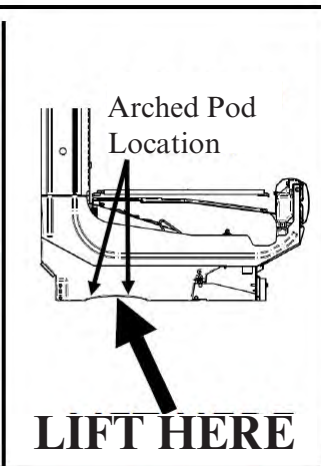

UNLOADING USING A PALLET JACK

A pallet jack is also very helpful in moving a merchandiser to its permanent location. It can also be used to remove optional casters or to shim the case.



OPTIONAL CASTERS AND DOLLIES

Cases may be equipped with factory installed casters or dollies. Instructions for removing the casters or dollies are included in a separate document, shipped with the case. Use caution when transporting cases from the truck to the store location.

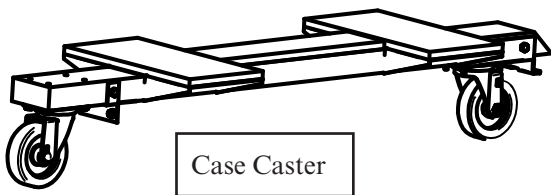

WARNING

- » Use caution when moving cases with casters or dollies. Damage to equipment and personal injury could occur from improper handling.

WARNING

- » Use caution when working around refrigeration lines or water lines. Damage to equipment and personal injury could occur.

SERIAL PLATE LOCATION

Serial plates are located on the left side, facing the case. The serial plate contains information about the specific model and its operating parameters.

A second serial plate for these multi-deck cases is also located behind the return air grille in the same location as single-deck cases (shown below).

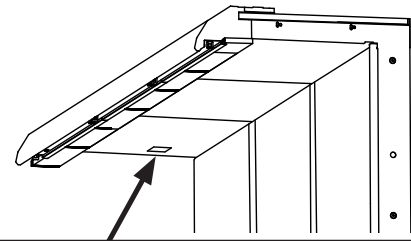

Serial Plate inside Canopy (multi-deck)

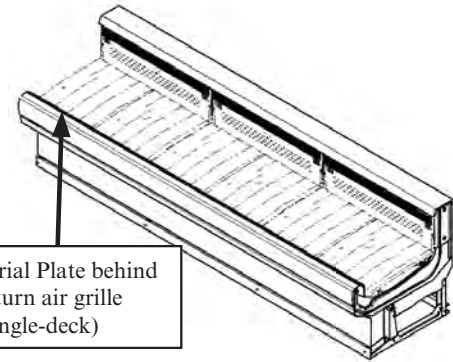

Serial Plate behind return air grille (single-deck)

QR CODE

Cases have a QR code located on the serial plate. Once you scan the QR code with a smart phone, all of the information about that case will be at your fingertips. Links to installation videos, data sheets with case specifications, the installation and operation manual, as well as a link to replacement parts from Hussmann's Performance Parts Website.



MERCHANDISERS SHIPPED WITH END INSTALLED

If the merchandiser was shipped with the end installed, two long bolts were used to hold the shipping brace to the end. If the shipping bolts are reinserted after removing the brace, they will extend into the product area. **THEREFORE, BE SURE TO REPLACE THESE BOLTS WITH THE SHORTER BOLTS PROVIDED.** NSF requires any bolt or screw in the product area be capped or cut off if it has more than three exposed threads.



Be careful not to damage the factory installed end while moving the merchandiser.

CAUTION
» Do not remove shipping braces until the merchandisers are positioned for installation.

END SHIPPING BRACES

Move the merchandiser as close as possible to its permanent location, then remove all packaging. Check for damage before discarding packaging. Remove all separately packed accessories such as kits and shelves.

Do not remove end braces until joining begins.
Recycle wooden braces and hardware.

SHIPPING RIDER

Some merchandisers are shipped on a rider to protect the factory installed front legs, and to make positioning the merchandiser easier. To remove the rider, remove bolts attaching rider to each leg.

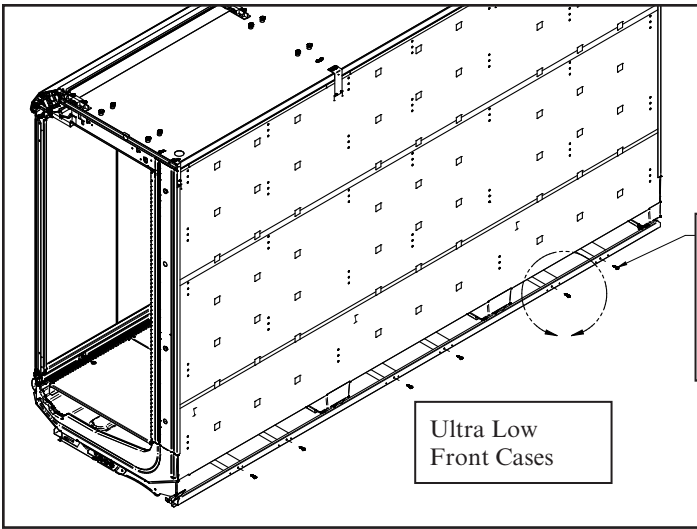
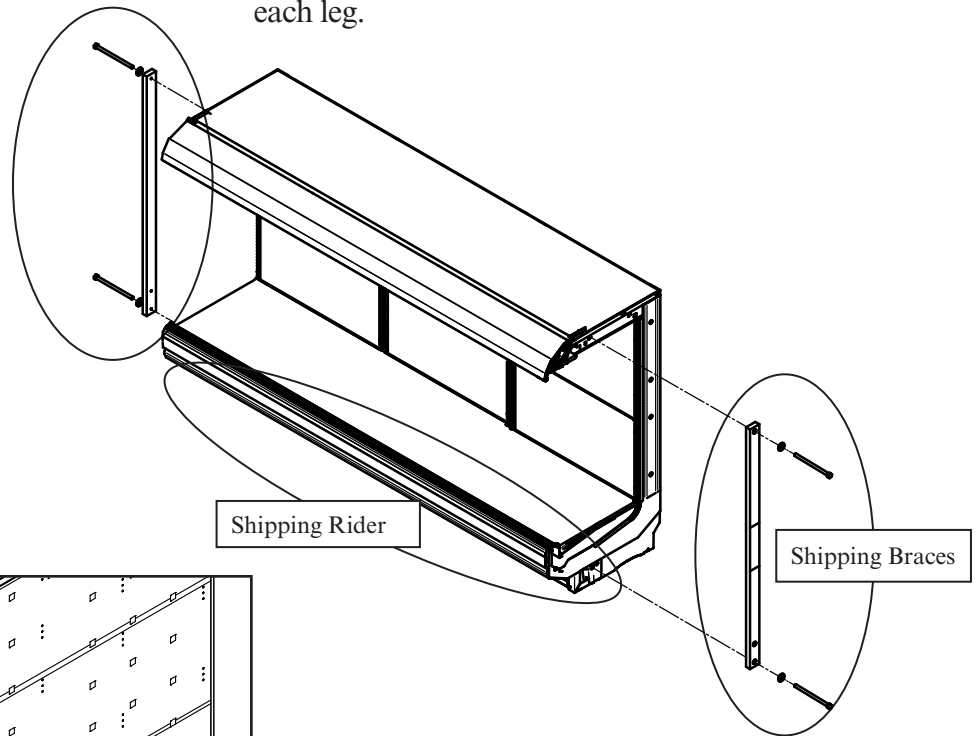

Remove 6 Screws and Wooden Supports Prior to Moving Case into Position (rear rail will remain attached to merchandiser)

MERCHANDISER LEVELING

IMPORTANT

Merchandisers must be installed level to ensure proper operation of the refrigeration system and to ensure proper drainage of defrost water. Pay close attention to case position during all steps of setting, joining and leveling.

NOTE: BEGIN LINEUP LEVELING FROM THE HIGHEST POINT OF THE STORE FLOOR.

Preparation

1. Using store blueprints, measure off and mark on floor the exact dimensions/locations of the merchandiser footprint. **A 2 inch space is required behind each merchandiser to prevent condensation.**
2. Snap a chalk line for the front and rear positions of the base pods.
3. Mark the location of each joint from front to back lines.
4. **USE SUPPLIED SHIMS TO LEVEL CASE. Shims are to be inserted under the black, plastic base pods.**

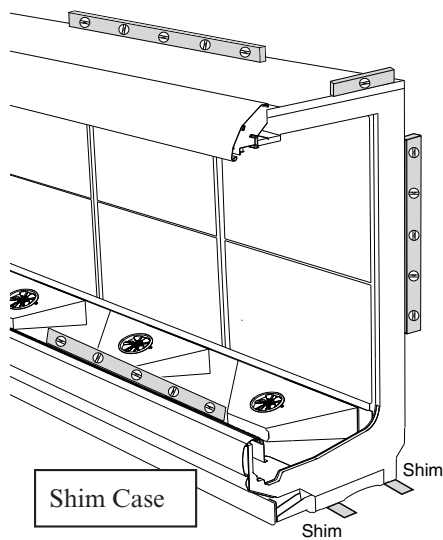

CAUTION

- » Tipping Hazard! Case tipping may occur if cases are not properly leveled and secured, or if cases are not properly loaded.



Case Lineup Leveling

1. **FLOORS ARE NOT LEVEL!** The whole lineup must be leveled on the same plane, left to right and front to back. This means that the entire lineup must be brought up to the level of the highest case in the lineup.



















Along the lines previously marked, find the highest point of the floor by:

- Walking the floor and noticing any dips or mounds;
- Using a string level; and
- Using a transit.

2. Position the first merchandiser at the highest point on the floor. Work outward from that point to create the merchandiser lineup.
3. Use a 48 inch (1220 mm) or longer level for end-to-end leveling. The rear edge of the top foam panel of the merchandiser is a good location for the level at the rear of the case.
4. For leveling the merchandiser front-to-rear, a 24 inch (610 mm) level should be placed on the lower flange of the merchandiser end frame. If the merchandiser has a factory installed end, the level should be placed on the canopy support brackets on top of the merchandiser. Suggested level locations are shown in the illustration.

JOINING CASES IN A LINEUP JOINING AND SEALING HARDWARE

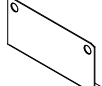
Description	Multi Deck Qty/Each	Convertible Qty/Each	Single Deck Qty/Each	Door Multi Deck Qty/Each
SEALER SILICONE ADHESIVE	1	1	1	1
GASKET 1/2 X 1/2 X 180	2	1	1	2
SCREW-SHEET METAL #8 X 5/8 PHIL HX HD	N/A	1	N/A	N/A
SCREW-CAP 1/4 x 3/4 HEX	N/A	N/A	N/A	2
BOLT HEX CAP 5/16 x 3/4	1	1	1	1
BOLT 5/16 x 2 3/4 GRADE 5 ZINC PLATED TAP	2	N/A	N/A	2
BOLT- TAP, 5/16 x 4 1/2, STEEL, ZINC FINISH, GR5 (Qty Varies)	5	2	1	5
BOLT- TAP, 5/16 x 7, STEEL, ZINC FINISH, GR5	1	1	1	1
WASHER-FLAT 5/16" ZINC (Qty Varies)	13	5	3	13
LOCKWSHR 1/4 SPLT STL	N/A	N/A	N/A	2
LOCKWSHR 5/16 SPLT STL	1	1	1	1
NUT-HEX 1/4	N/A	N/A	N/A	2
NUT-HEX 5/16 STEEL ZINC FINISH GRADE 8 (Qty Varies)	9	4	3	9
NUT-HEX 3/8-24 SERRATED FLANGE	4	N/A	N/A	4
PIN-ALIGNMENT	1	1	1	N/A
CONE-CASE ALIGNMENT (Qty Varies)	4	2	2	4
PLATE-BOTT DOOR RAIL ALIGNMENT	N/A	N/A	N/A	1
BRACKET-CASE JOINING	4	N/A	N/A	4
BRACKET-FASCIA ALIGNMENT IC2 & IC3	N/A	1	N/A	N/A
COVER-HAND RAIL JOINT	1	1	1	N/A
TAPE-BUTYL 1/16 x 2" X 49"	1	1	1	1

- Screw-Sheet Metal #8 x 5/8 
- Screw-Cap 1/4 x 3/4 
- Bolt-5/16 x 3/4 
- Bolt-5/16 x 2 3/4 
- Bolt-5/16 x 4 1/2 
- Bolt-5/16 x 7 
- Washer Flat-5/16 
- Washer Lock-1/4 
- Washer Lock-5/16 
- Nut Hex-1/4 
- Nut Hex-5/16 
- Nut Hex-3/8 Serr Flange 
- Pin-Alignment 
- Cone-Alignment 
- Plate-Bottom Door Rail Alignment 
- Bracket-Case Joining 
- Bracket-Fascia Alignment IC2 & IC3 
- Cover-Handrail Joint 

IMPORTANT:

Do not pull cases together with bolts. Cases must be moved together as close as possible. Follow sequence balloons to tighten bolts.

Apply gasket to only one side of case joint.

Remove end shipping braces as described on Page 1-4.

Cases must be leveled as described on Page 1-5.

Removed any casters - if installed.

Install case lineup from left to right.

Remove shelves, display racks, pans & interior back panels at the joining area.

Insert gasket into case channels the entire length with no gaps.

Do not stretch gasket, especially around corners.

Do not butt gaskets, always overlap them.

Remove paper backing after gasket has been applied.

Perimeter gasket is required by NSF.

Apply a continuous bead of neutral curing silicone sealant.

Joints must be air tight to prevent formation of ice or condensation.

**APPLY GASKETS
(MULTI-DECK)**

Case bolting details begin on the next page.

LEGEND:

- A = 1/2 x 1/2 INCH GASKET
- B = NEUTRAL CURING SILICONE SEALANT
- C = PIN-ALIGNMENT
- D = COVER-HAND RAIL JOINT

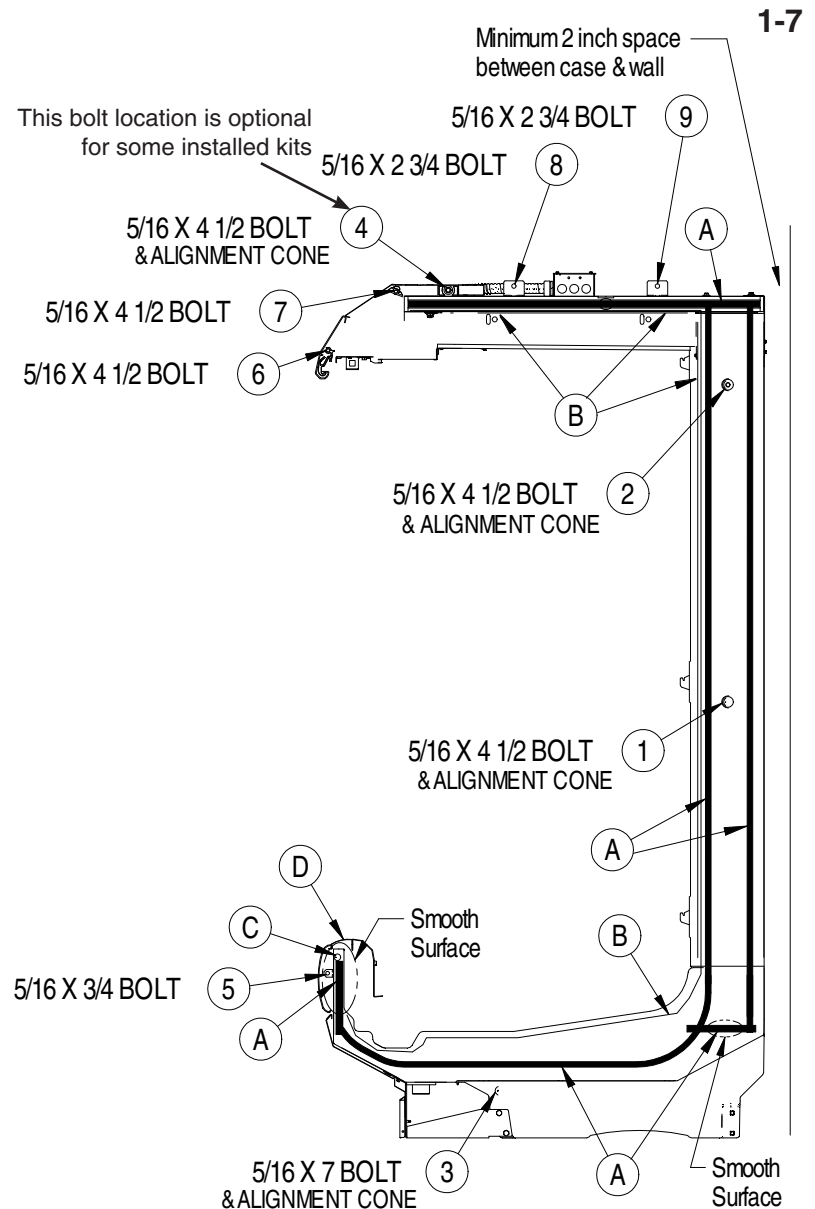

IMPORTANT:

- Do not pull cases together with bolts. Cases must be moved together as close as possible Follow sequence balloons to tighten bolts.
- Merchandiser case joint & end gasket to be applied on only one side of joint.
- Merchandiser partition gasket to be applied on both sides of joint.
- Remove end shipping braces as described on Page 1-4
- Cases must be leveled as described on Page 1-5
- Removed any casters - if installed
- Install case lineup from left to right
- Remove shelves, display racks, pans & interior back panels at the joining area
- Insert gasket into case channels the entire length with no gaps
- Do not stretch gasket, especially around corners
- Do not butt gaskets, always overlap them
- Remove paper backing after gasket has been applied
- Perimeter gasket is required by NSF
- Apply a continuous bead of neutral curing silicone sealant
- Joints must be air tight to prevent formation of ice or condensation.

CASE JOINING (MULTI-DECK)

Refer to detail views

LEGEND:

C = PIN-ALIGNMENT

Do not pull cases together with bolts. Cases must be moved together as close as possible. Follow sequence balloons 1, 2, 3 to tighten bolts.

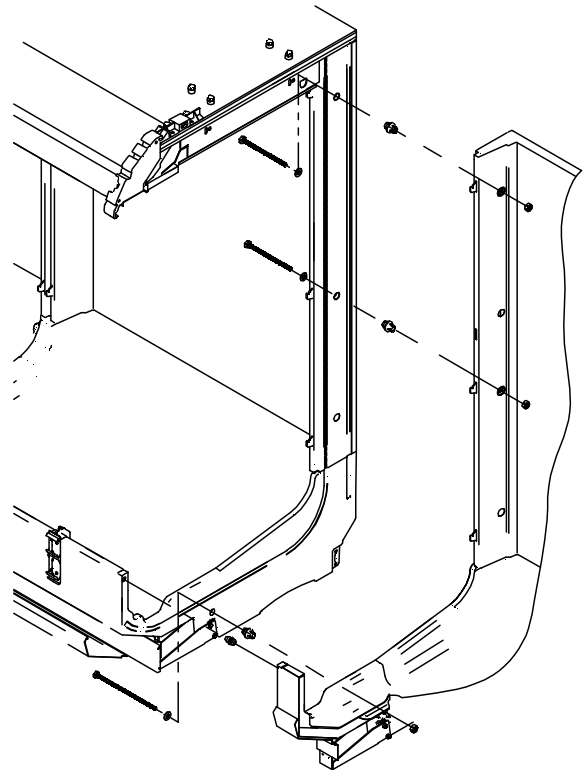
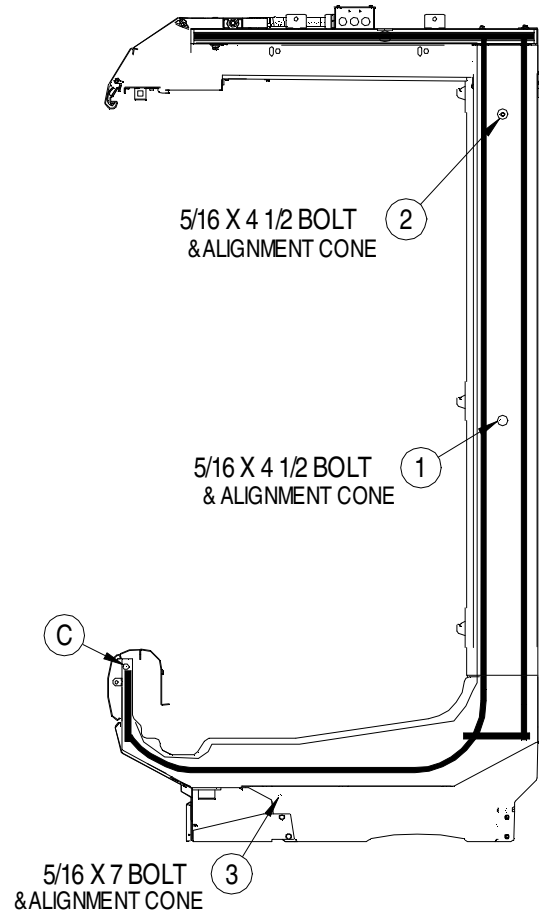

CASE JOINING (MULTI-DECK)

Refer to detail views

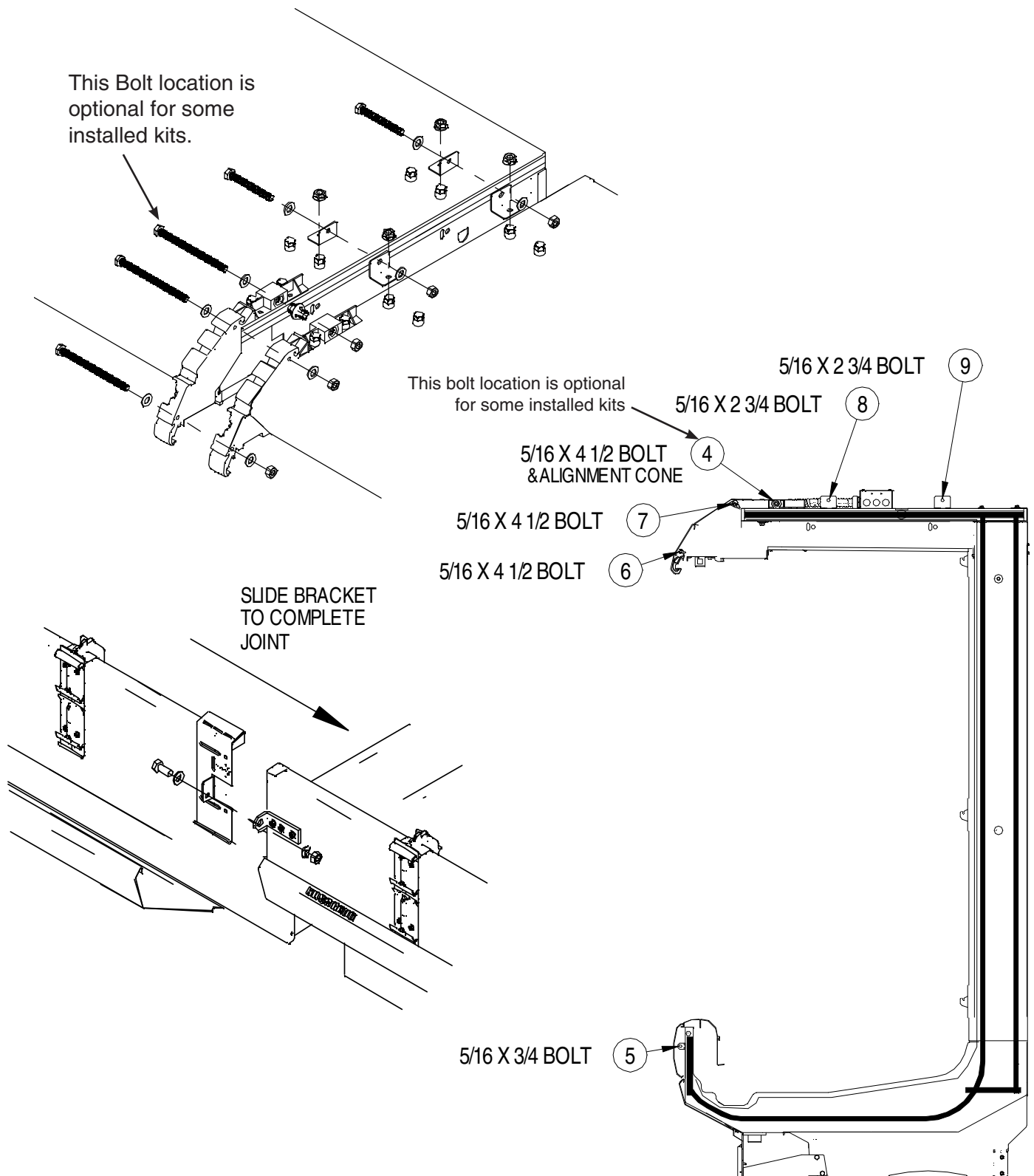

1-10

CASE JOINING (MULTI-DECK)

Refer to detail views

LEGEND:

D = COVER-HAND RAIL JOINT

Push Cover
in this direction
to snap fit

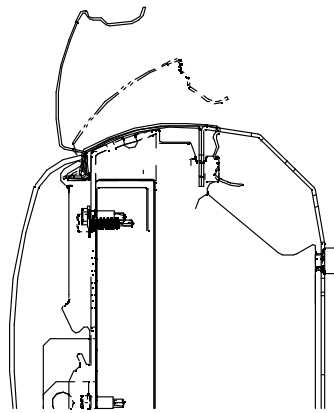

Cover-Hand Rail Joint

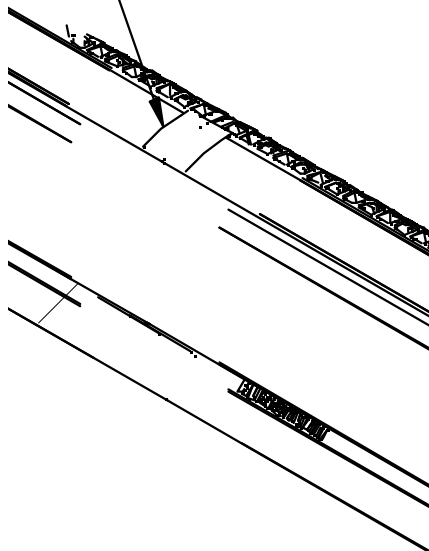

D

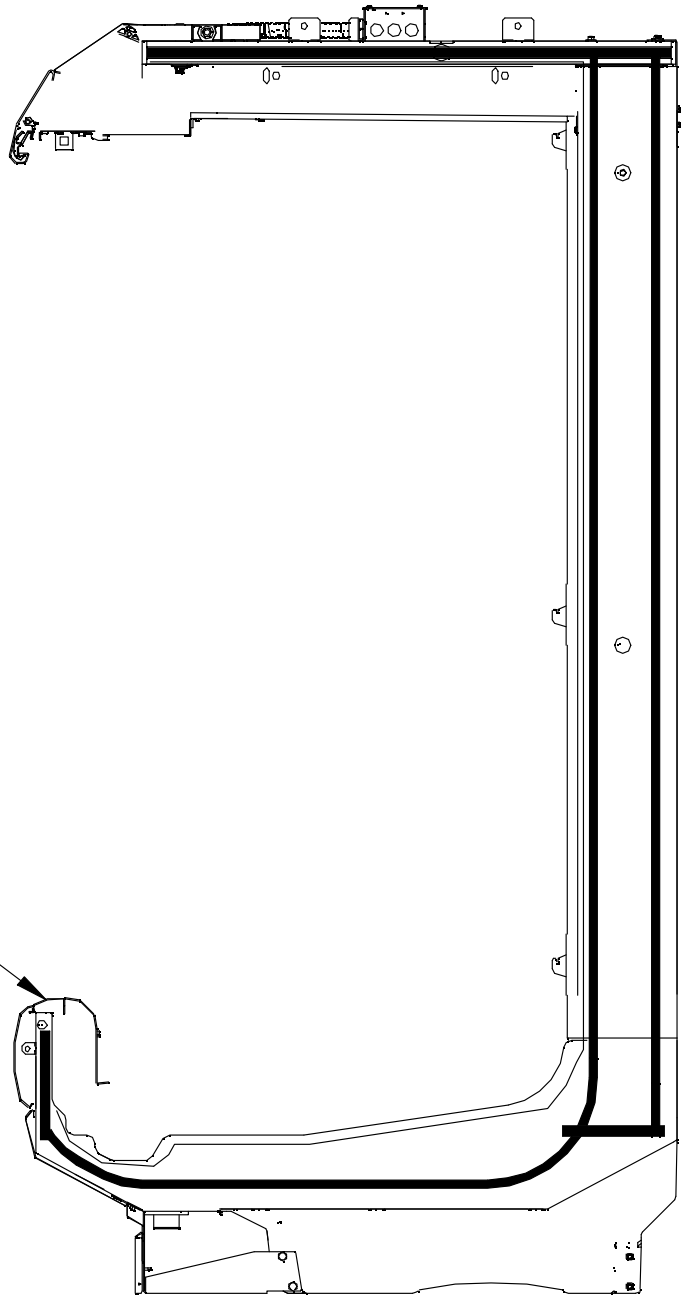

P/N 3074287_J

JOINING DOOR CASES - APPLY GASKETS (DOOR CASES)

Case bolting details begin on the next page.
Refer to Page 1-6 for hardware list.

Do not pull cases together with bolts.
Cases must be moved together as close
as possible. Follow sequence balloons
to tighten bolts.

LEGEND:

A = 1/2 x 1/2 INCH GASKET

B = NEUTRAL CURING SILICONE SEALANT

C = PIN-ALIGNMENT

F = PLATE BOTTOM DOOR RAIL ALIGNMENT

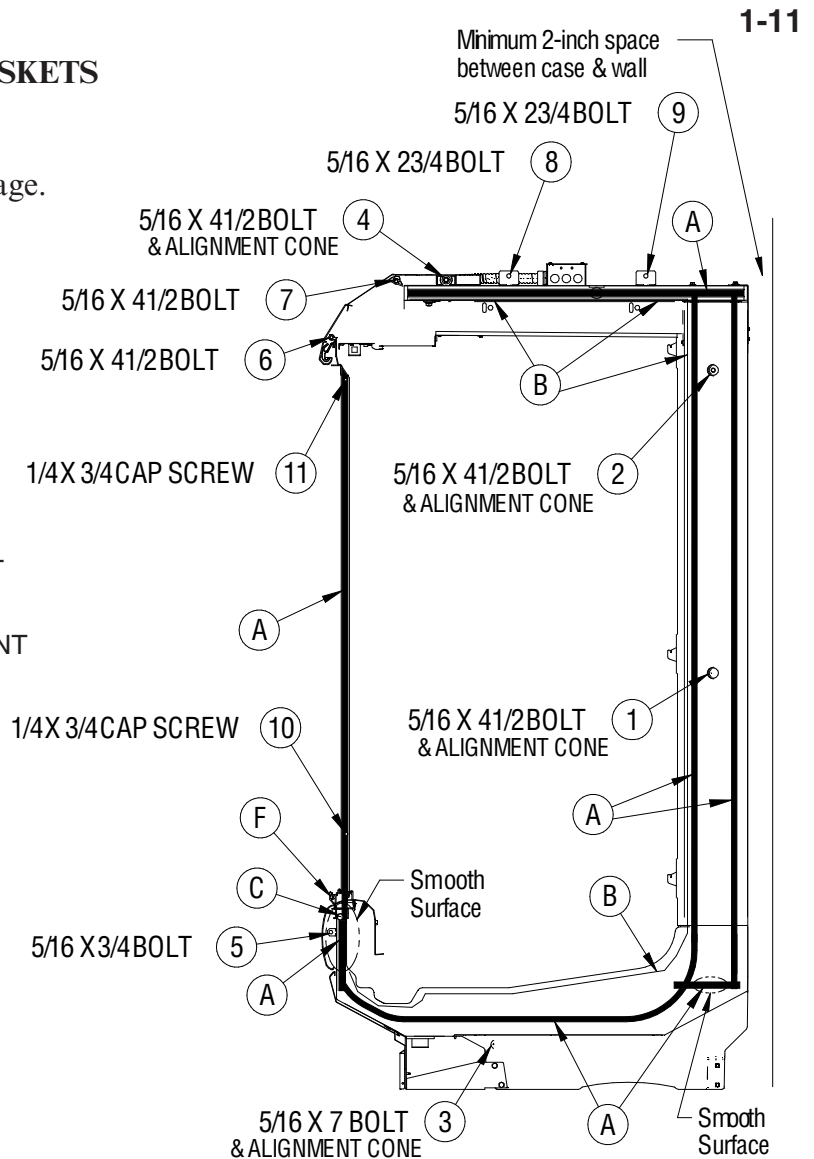

IMPORTANT:

Do not pull cases together with bolts. Cases must be moved together as close as possible. Follow sequence balloons to tighten bolts.

Merchandiser case joint & end gasket to be applied on only one side of joint.

Merchandiser partition gasket to be applied on both sides of joint.

Remove end shipping braces as described on Page 1-4

Cases must be leveled as described on Page 1-5

Remove any casters - if installed

Install case lineup from left to right

Remove shelves, display racks, pans & interior back panels at the joining area

Insert gasket into case channels the entire length with no gaps

Do not stretch gasket, especially around corners

Do not butt gaskets, always overlap them

Remove paper backing after gasket has been applied

Perimeter gasket is required by NSF

Apply a continuous bead of neutral curing silicone sealant

Joints must be air tight to prevent formation of ice or condensation.

**CASE JOINING
(DOOR CASES)
CONTINUED**

LEGEND:

C=PIN-ALIGNMENT

F=PLATE-BOTT DOOR RAIL ALIGNMENT

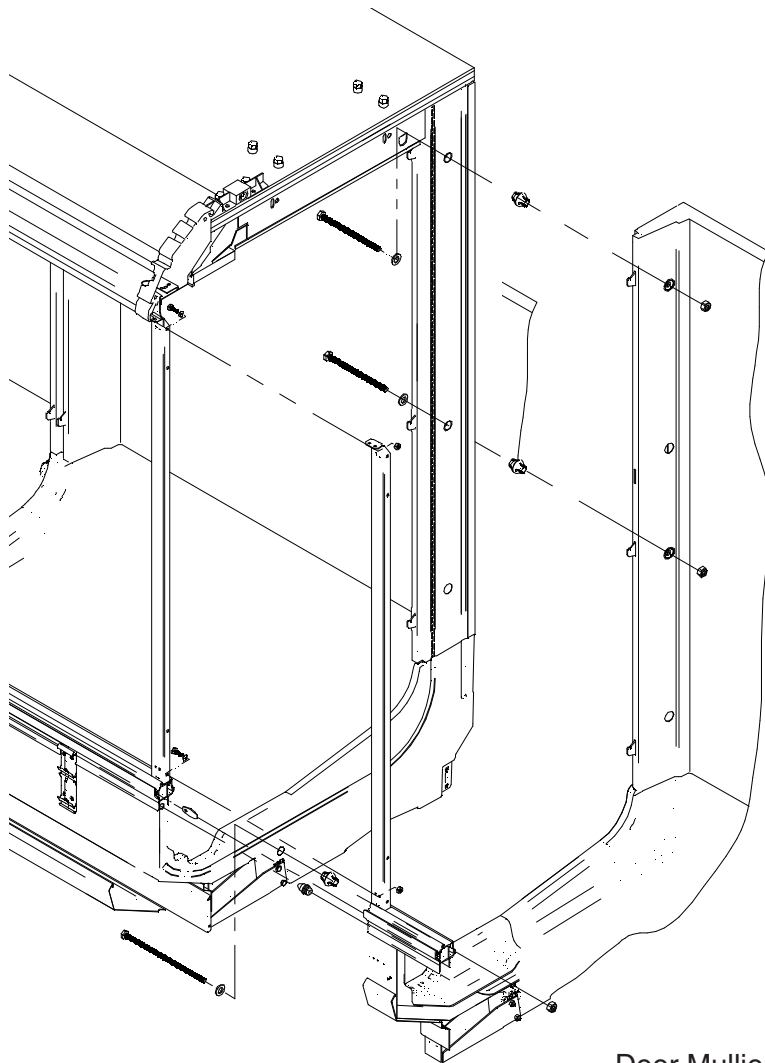

1/4 X 3/4 CAP SCREW 11

5/16 X 4 1/2 BOLT & ALIGNMENT CONE 2

1/4 X 3/4 CAP SCREW 10

5/16 X 4 1/2 BOLT & ALIGNMENT CONE 1

F

C

5/16 X 7 BOLT & ALIGNMENT CONE 3

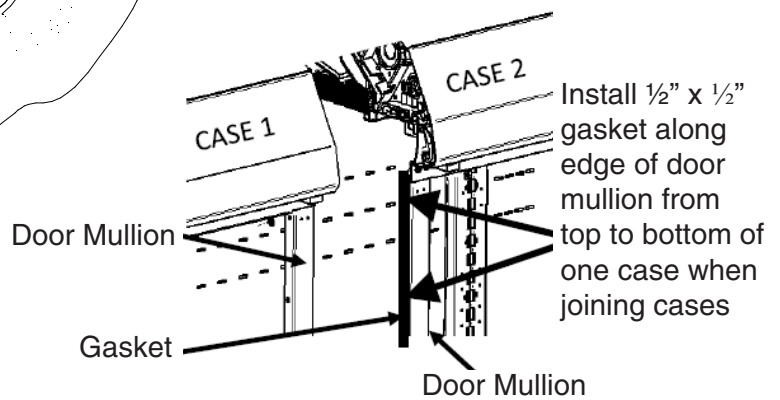

Door Gasket Installation

CASE JOINING (DOOR CASES)

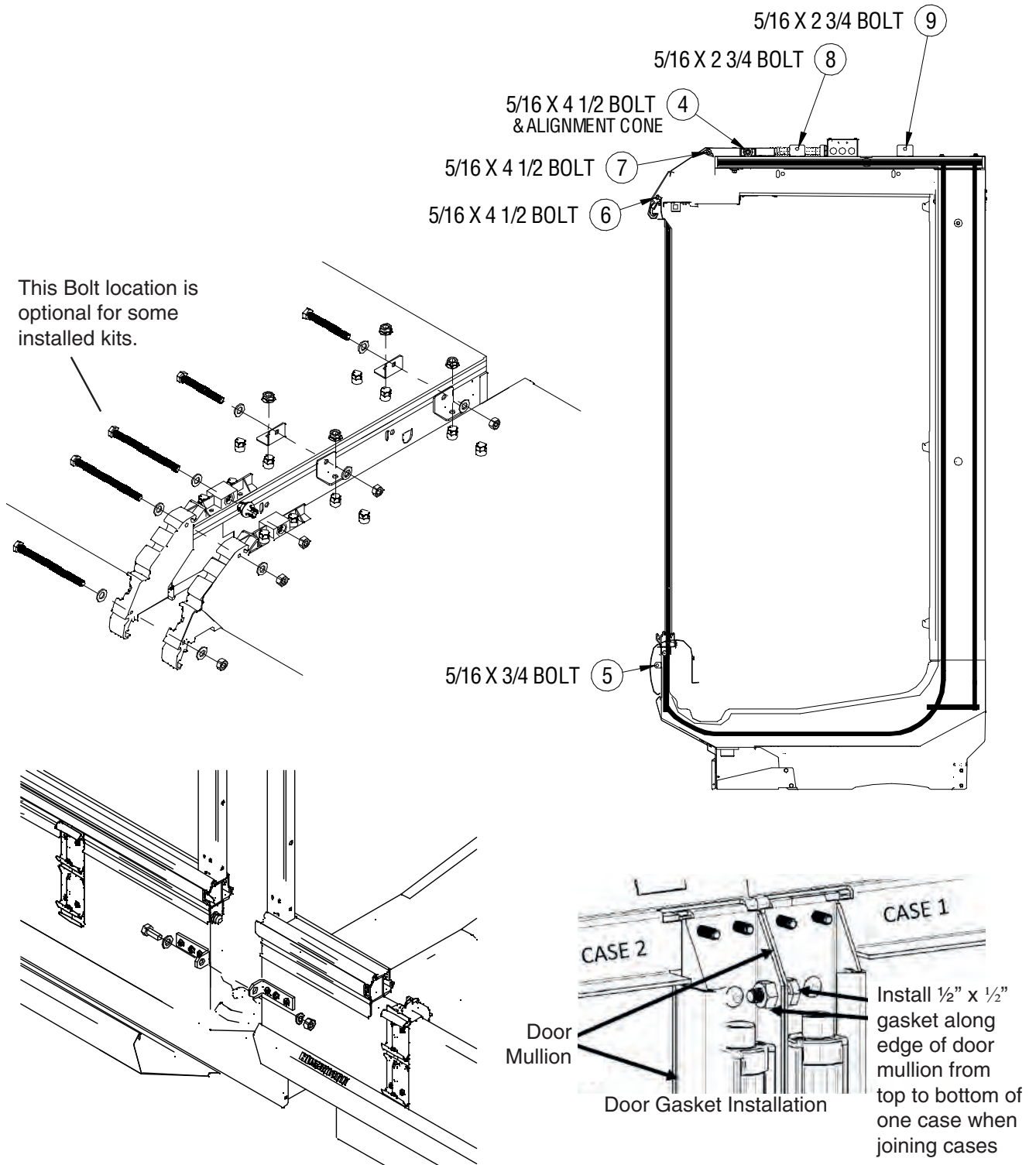

**DOORS
(INSTALLING, REMOVING, ADJUSTING)**

A. To install a door:
Lean door back, and push pin into mullion.
Ensure push pins are fully seated in canopy support bracket.

B. To remove a door:
Raise door up and lift rod bottom out of bottom hinge plate hole

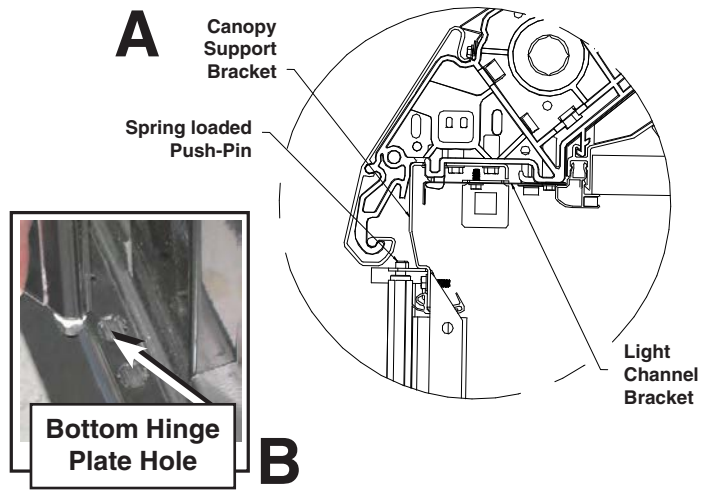

ADJUSTING ECOVISION DOORS

Check that all doors open and close properly.

Excessive ambient conditions may cause condensation and therefore sweating of doors. Facility operators should monitor doors and floor conditions to ensure safety of persons.

A. Leveling — Merchandisers must be installed level to ensure proper operation of the refrigeration system, and to ensure proper drainage of defrost water.

B. Door Adjustment — Loosen the screws A, B and C as shown below (Do not remove the screws completely).

Glass alignment is also affected with improper leveling of the merchandisers. All steps of setting joining and case leveling attention to the glass position is critical. Do not attempt to make glass adjustments prior to case leveling.

Slide the bottom plate left and right until proper alignment is achieved. Retighten the screws A, B and C. Install fasteners in locations 1 and 2 as shown below.

EcoVision Door Alignment - Modular Bottom Hinge Plate

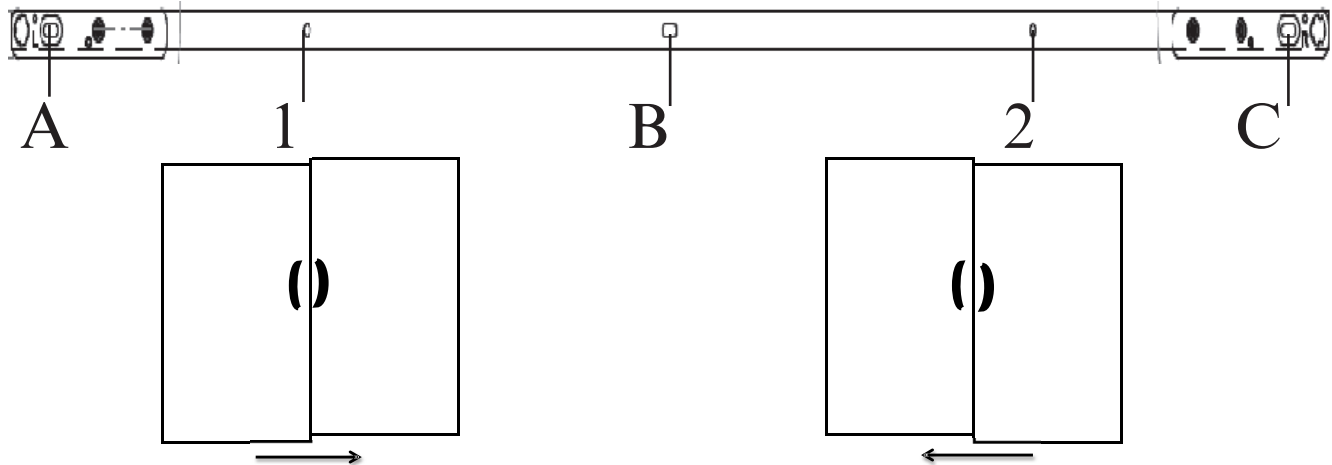

To Correct Shift the Bottom Plate to the Right

To Correct Shift the Bottom Plate to the Left

ADJUSTING DOOR CLOSING SPEED

The door's closing speed is factory adjusted, but the door may also be field adjusted.

Do the following to adjust the doors:

1. To release door tension, open the door to 90° and lift up the door from the bottom. Lift the torsion rod out of the star pattern in the bottom hinge plate. (The door should be lifted out of the star pattern in the hinge plate to prevent any damage to the star pattern.)
2. Use a ½ in. open end wrench to tighten the torsion of the door. Adjust tension with each audible click. Doors should be adjusted to 4 clicks, more if needed. Door must be properly resealed in star pattern of hinge plate after torsion tension is applied.

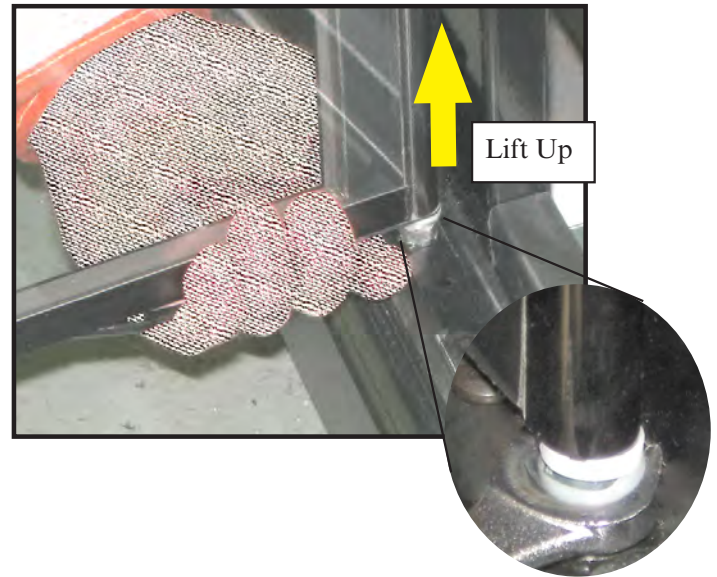

REPLACING LED VERTICAL MULLION LIGHT BARS

LED vertical mullion lights are an available lighting option for EcoVision doors. Center fixtures illuminate the middle of the case, and the end fixtures illuminate the ends, or sides of the case.

These LEDs have different shaped lenses. They are not to be interchanged. Contact your Hussmann representative to order replacements.

The light bars are attached to the door mullions with mounting clips, and can be replaced similar to the canopy lights — just remove them from the mounting clips, and connect new wires at quick connect.

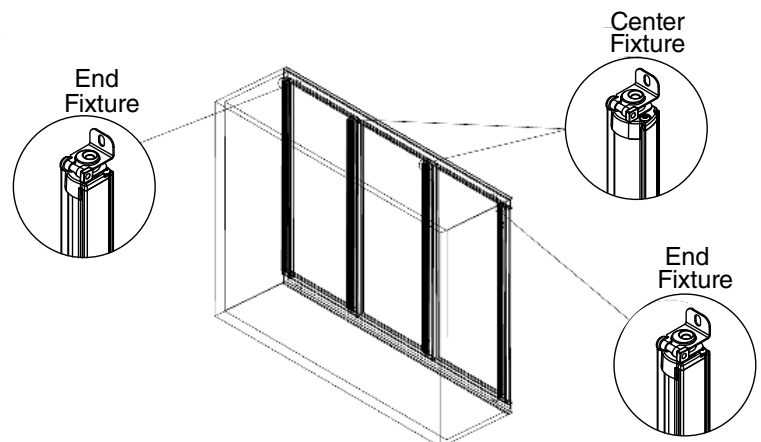

SEALING LINEUP JOINTS (all cases)

The joint between the two joined case must be sealed for sanitation. Apply Butyl tape across the case joint. Apply a long, continuous bead of silicone to fill any gaps between the cases.

Be sure to start from the back and go all the way to the air return as shown in the illustration below.

⚠ WARNING

» Use caution when working around refrigeration lines or water lines, damage to equipment and personal injury could occur.

📄 ! IMPORTANT Fill any gaps between cases with silicone.

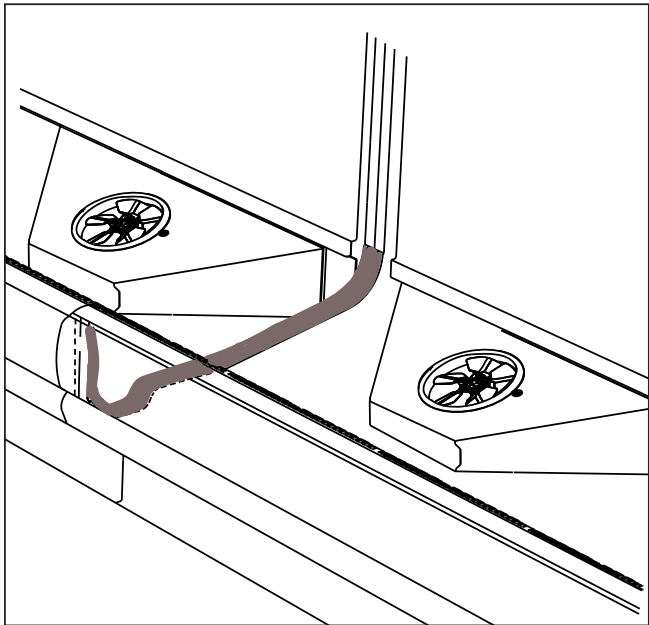

Apply Butyl Tape

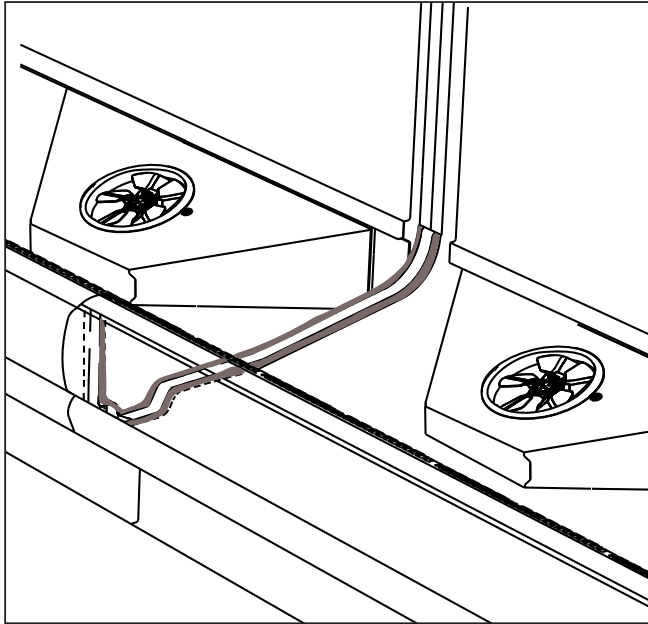

**Apply Neutral Curing
Silicone Sealant**

**Apply Neutral Curing Silicone Sealant
in any gaps between the Case Joints.**













INSTALLING END ASSEMBLIES

Remove shipping brace. Brace screws will be replaced with shorter screws found in packout kit. Ensure Nut Retainers are in place. Apply Gaskets and Silicone to End Frame.

Apply 1/2 x 1/2 in. (12.7 mm) x (12.7 mm) gaskets into the case channels. Check that the gasket is properly inserted into the entire length of the channels with no gaps. Apply silicone between case end cap and end.

FIELD INSTALLED HARDWARE	Multi Deck Qty/Each	Convertible Qty/Each	Single Deck Qty/Each	View End Multi Deck Qty/Each
Description				
SEALER SILICONE ADHESIVE	1	1	1	1
GASKET 1/2 X 1/2 X 180	1	1	1	1
SCREW SM 10-16X3/4 HX WASHER	1	1	1	N/A
BOLT 5/16 x 2 3/4 GRADE 5 ZINC PLATED TAP*	4	2	1	5
BOLT- TAP, 5/16 x 4 1/2, STEEL, ZINC FINISH, GR5	1	1	1	1
WASHER-FLAT 5/16" ZINC*	7	4	2	8
NUT-HEX 5/16 STEEL ZINC FINISH GRADE 8*	3	2	2	4
NUT-PUSH 5/16" RETAINER STEEL ZINC*	2	1	1	2
NUT-J RETAINER 5/16"	2	1	N/A	2
BUTTON-PLUG 7/8 DIA*	5	3	2	6

*Quantities may vary depending on which type of end is to be placed on case.

- Screw-sm #10 x 3/4 Hex Washer  
- Bolt-5/16 x 2 3/4  
- Bolt-5/16 x 4 1/2  
- Washer Flat-5/16  
- Nut Hex-5/16  
- Nut-Push 5/16 
- Nut-J Retainer 
- Button-Plug 

IMPORTANT:

Do not pull cases together with bolts. Cases must be moved together as close as possible. Follow sequence balloons to tighten bolts.

Apply case end gasket to only one side of case joint.

Remove end shipping braces as described on Page 1-4.

Cases must be leveled as described on Page 1-5.

Removed any casters - if installed.

Install case lineup from left to right.

Remove shelves, display racks, pans & interior back panels at the joining area.

Insert gasket into case channels the entire length with no gaps.

Do not stretch gasket, especially around corners.

Do not butt gaskets, always overlap them.

Remove paper backing after gasket has been applied.

Perimeter gasket is required by NSF.

Apply a continuous bead of neutral curing silicone sealant.

Joints must be air tight to prevent formation of ice or condensation.

CASE END INSTALLATION MULTI-DECK (DOOR)

Refer to detail views

LEGEND:

A = 1/2 x 1/2 INCH GASKET

B = NEUTRAL CURING SILICONE SEALANT

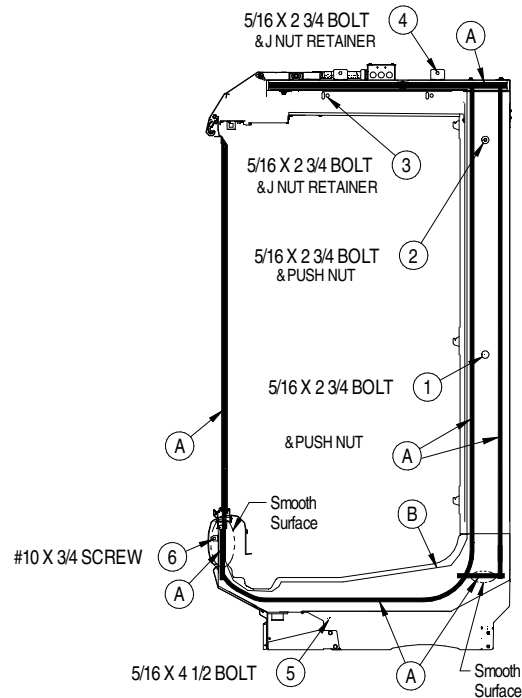
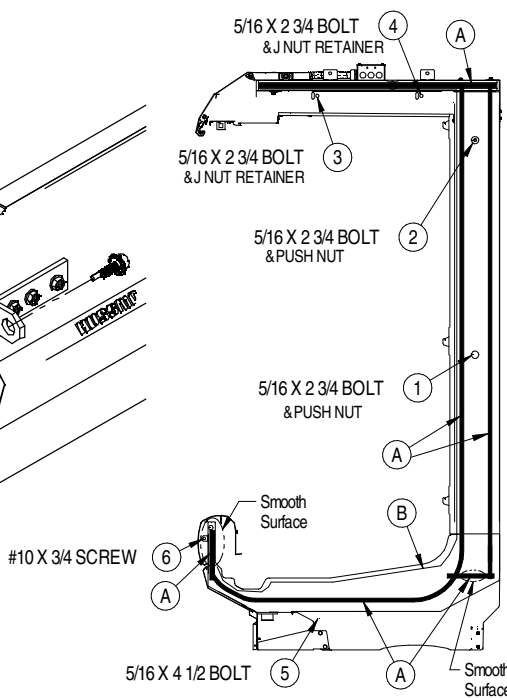
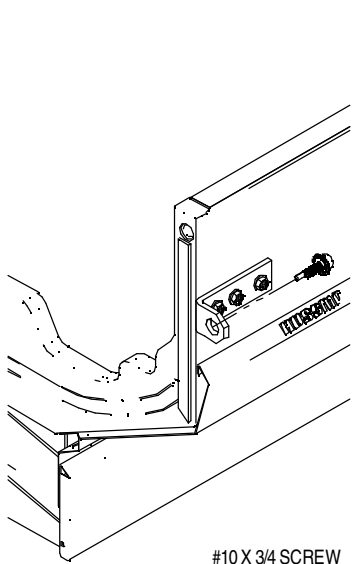
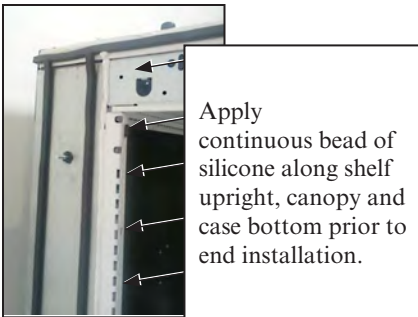
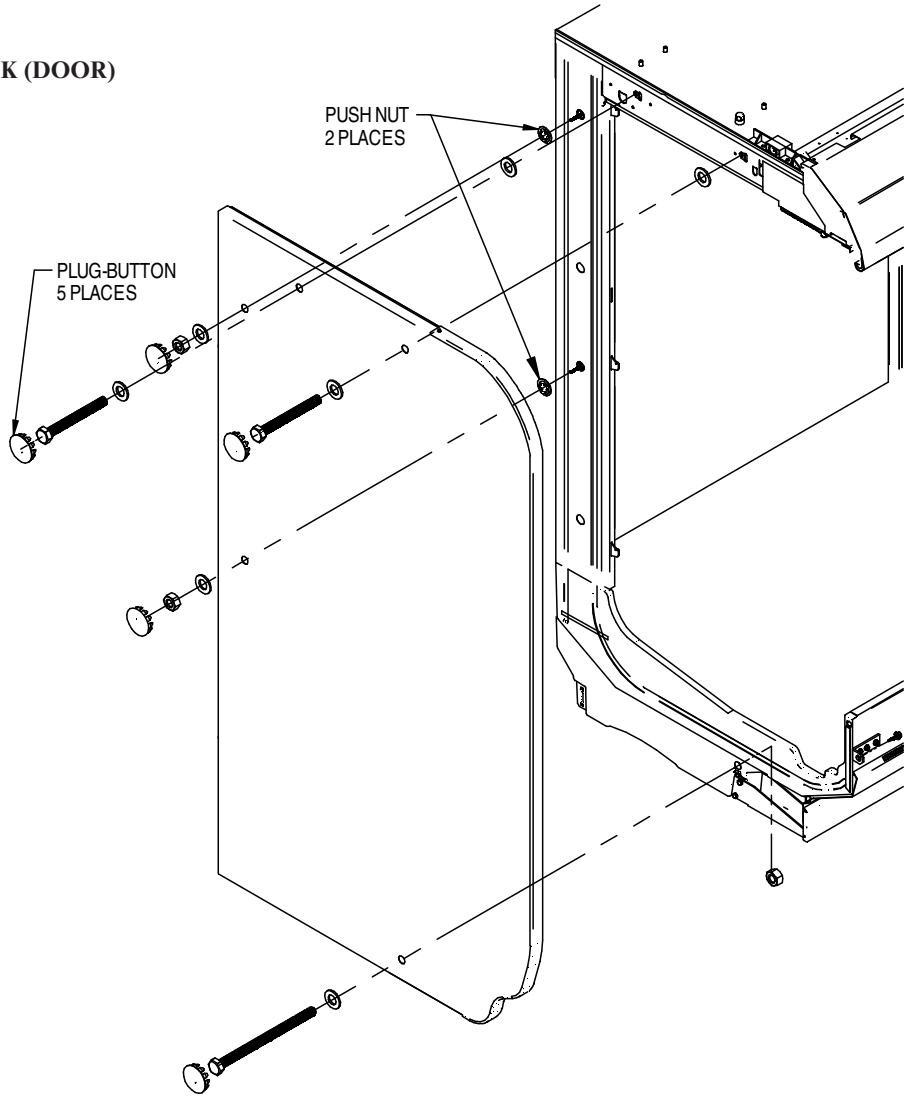

CASE VIEW END INSTALLATION MULTI-DECK (DOOR)

Refer to detail views

LEGEND:

A = 1/2 x 1/2 INCH GASKET

B = NEUTRAL CURING SILICONE SEALANT

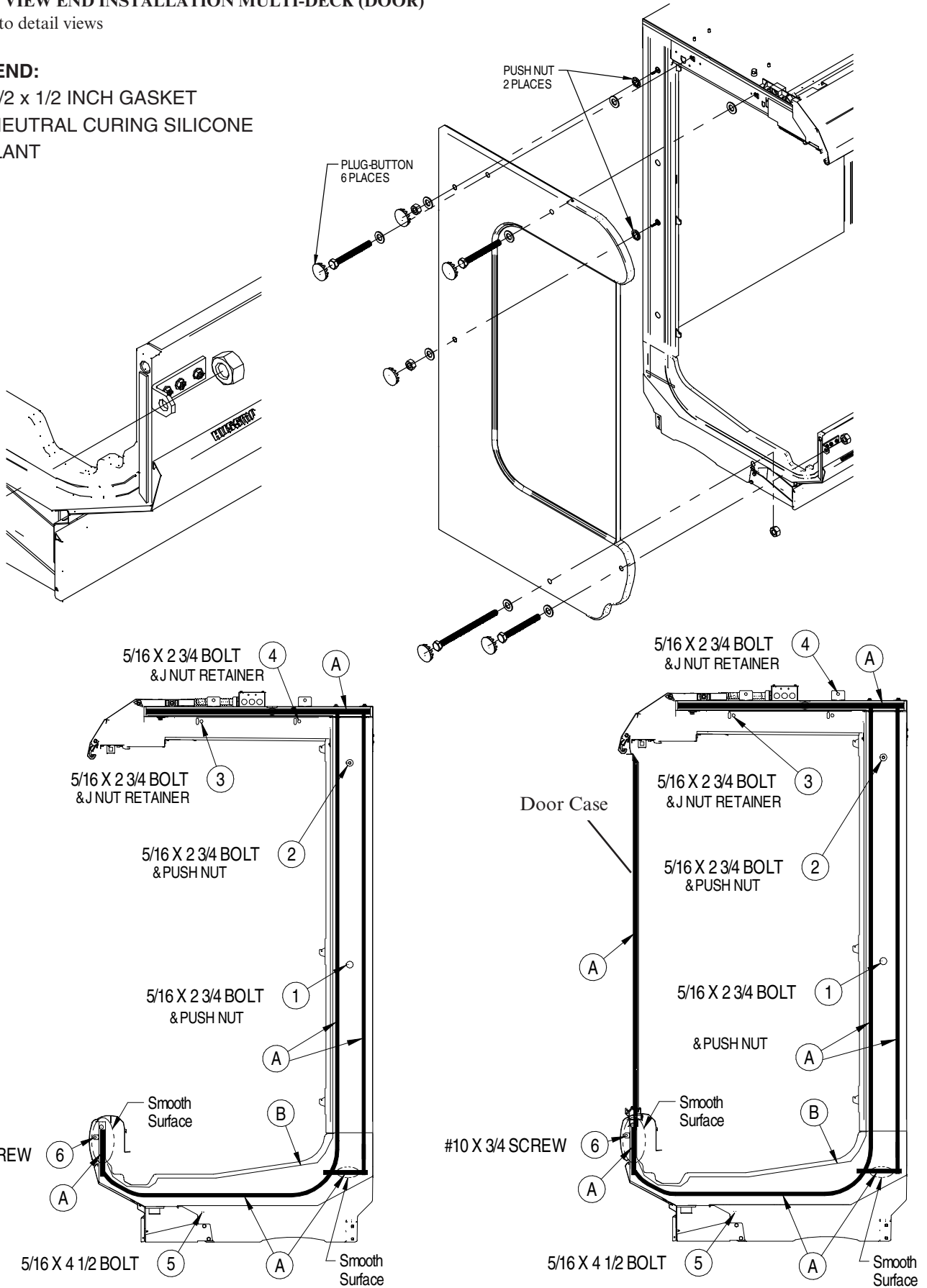

PARTITION HARDWARE

Remove shipping brace. Brace screws will be replaced with shorter screws found in packout kit. Ensure Nut Retainers are in place. Apply Gaskets and Silicone to End Frame.

Apply 1/2 x 1/2 in. (12.7 mm) x (12.7 mm) gaskets into the case channels. Check that the gasket is properly inserted into the entire length of the channels with no gaps. Apply silicone between case end cap and end.

Description	Alt Canopy Applications	Multi Deck/Door Same Case Qty/ Each	Multi Deck/Door Different Case Qty/ Each	Convertible Different Case Qty/ Each
SEALER SILICONE ADHESIVE	Refer to Multi Deck Different Case	2	2	2
GASKET 1/2 X 1/2 X 180	Refer to Multi Deck Different Case	2	2	2
SCREW-SHEET METAL #8 X 5/8 PHIL HX HD	3 or 4	1	1	1
SCREWSM10-16X3/4 HX WASHER	1	2	2	2
BOLT HEX 1/4 x 1 1/2	Refer to Multi Deck Different Case	N/A	2	N/A
BOLT HEX 1/4 x 2 1/4*	1	N/A	2	2
BOLT HEX 1/4 x 4.0	Refer to Multi Deck Different Case	N/A	1	N/A
BOLT HEX 5/16 x 2 3/4*	Refer to Multi Deck Different Case	1	4	2
BOLT-HEX 5/16 x 4 1/2	Refer to Multi Deck Different Case	2	1	N/A
BOLT-HEX 5/16 x 7.0*	Refer to Multi Deck Different Case	2	N/A	N/A
BOLT-HEX 5/16 x 8.0	Refer to Multi Deck Different Case	1	N/A	1
WASHER-FLAT 1/4*	1	N/A	5	2
WASHER-FLAT 5/16*	Refer to Multi Deck Different Case	8	5	4
NUT-HEX 5/16*	Refer to Multi Deck Different Case	7	3	4
NUT-HEX 3/8-24 SERRATED FLANGE	1	4	2	N/A
NUT-PUSH5/16" RETAINERSTEEL ZINC*	Refer to Multi Deck Different Case	2	N/A	N/A
NUT-J RETAINER5/16*	Refer to Multi Deck Different Case	1	2	1
BRACKET-CASE JOINING	N/A	4	2	N/A
BRACKET-CANOPY (ALT APPLICATIONS)	1	N/A	N/A	N/A
BRACKET-UNIBODY (ALT APPLICATIONS)	1	N/A	N/A	N/A
BUTTON-PLUG7/8 DIA*	Refer to Multi Deck Different Case	N/A	2	1
BRACKET-CLOSEOFF SPLASHGUARD	Refer to Multi Deck Different Case	1	1	1
CLOSEOFF-SPLASHGUARD	Refer to Multi Deck Different Case	1	1	1

*Quantities may vary depending on which type of end is to be placed on case.

- Screw-Sheet Metal #8 x 5/8
- Screw-sm #10 x 3/4 Hex Washer
- Bolt-1/4 x 1 1/2
- Bolt-1/4 x 2 1/4
- Bolt-1/4 x 4
- Bolt-5/16 x 2 3/4
- Bolt-5/16 x 4 1/2
- Bolt-5/16 x 7
- Bolt-5/16 x 8
- Washer Flat-1/4
- Washer Flat-5/16
- Nut Hex-5/16
- Nut Hex-3/8 Serr Flange
- Nut-Push 5/16
- Nut-J Retainer
- Bracket-Case Joining
- Bracket-Canopy (Alt Applications)
- Bracket-Unibody (Alt Applications)
- Button-Plug
- Bracket-Closeoff Splashguard
- Closeoff-Splashguard

IMPORTANT:

Do not pull cases together with bolts. Cases must be moved together as close as possible. Follow sequence balloons to tighten bolts.

Apply case end gasket to only one side of case joint.

Remove end shipping braces as described on Page 1-4.

Cases must be leveled as described on Page 1-5.

Removed any casters - if installed.

Install case lineup from left to right.

Remove shelves, display racks, pans & interior back panels at the joining area.

Insert gasket into case channels the entire length with no gaps.

Do not stretch gasket, especially around corners.

Do not butt gaskets, always overlap them.

Remove paper backing after gasket has been applied.

Perimeter gasket is required by NSF.

Apply a continuous bead of neutral curing silicone sealant.

Joints must be air tight to prevent formation of ice or condensation.

**MULTI DECK (DOOR)
SAME CASE PARTITIONS**

Refer to detail views

LEGEND:

A = 1/2 x 1/2 INCH GASKET

B = NEUTRAL CURING SILICONE SEALANT

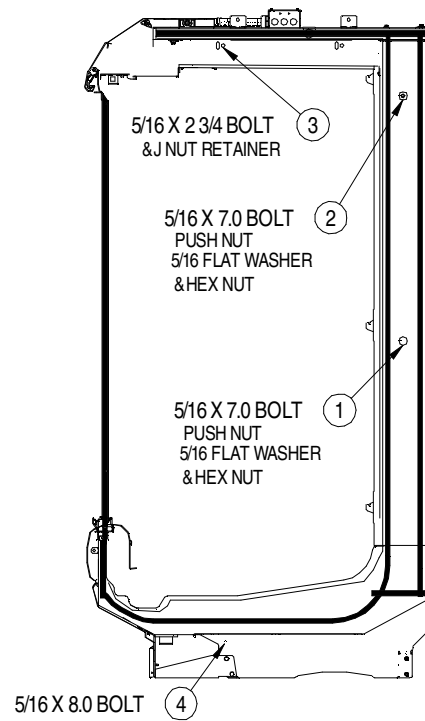
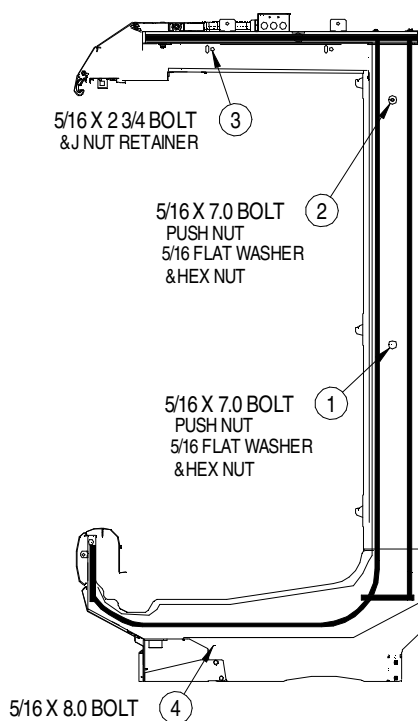
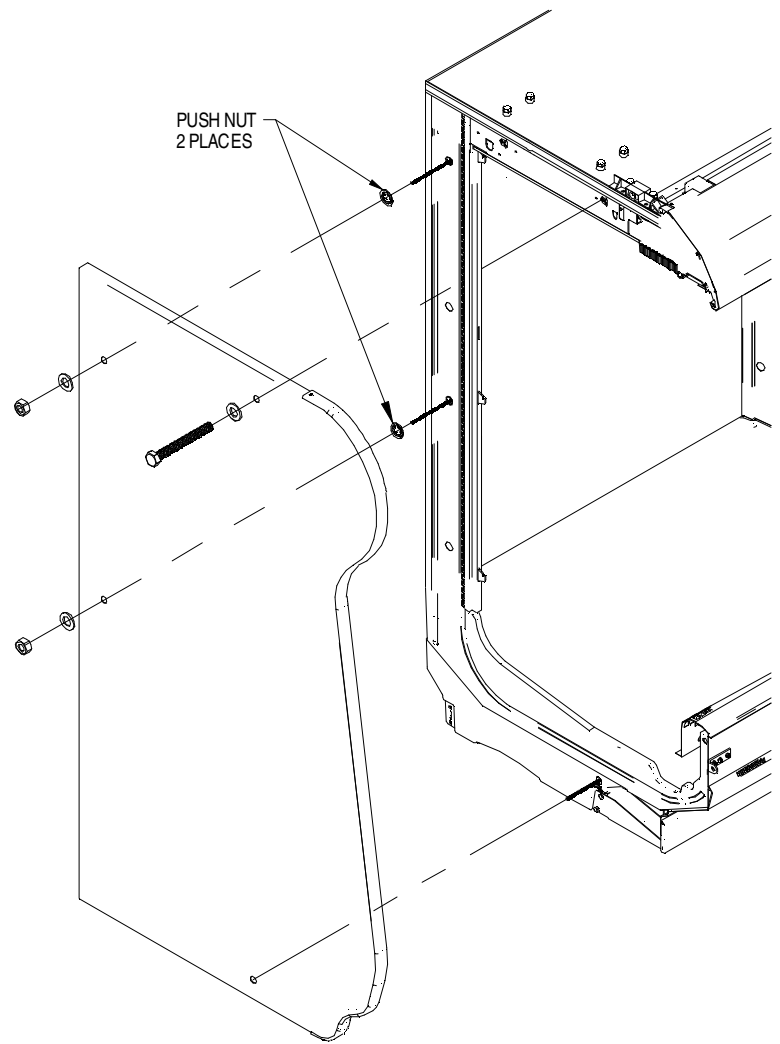

**MULTI DECK (DOOR)
SAME CASE PARTITIONS CONTINUED**

Refer to detail views

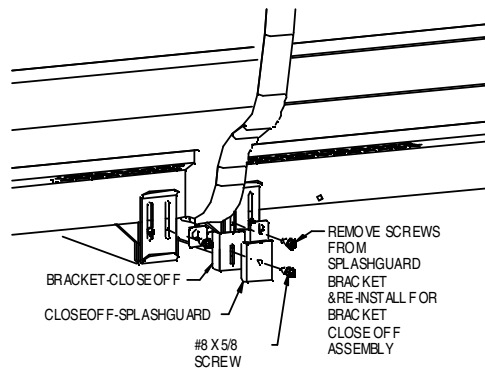
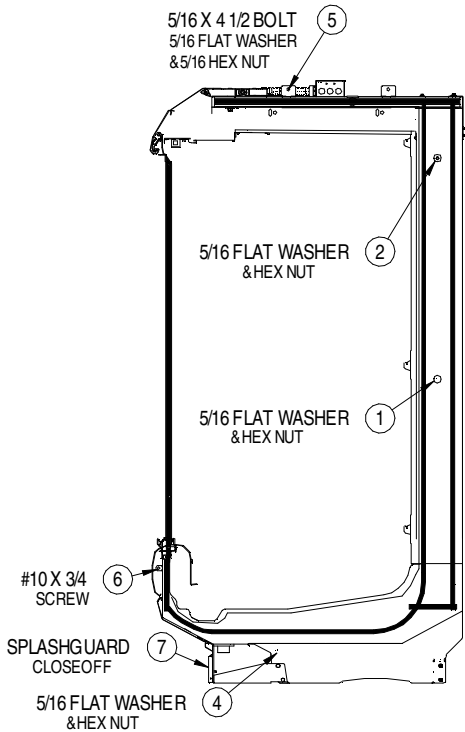
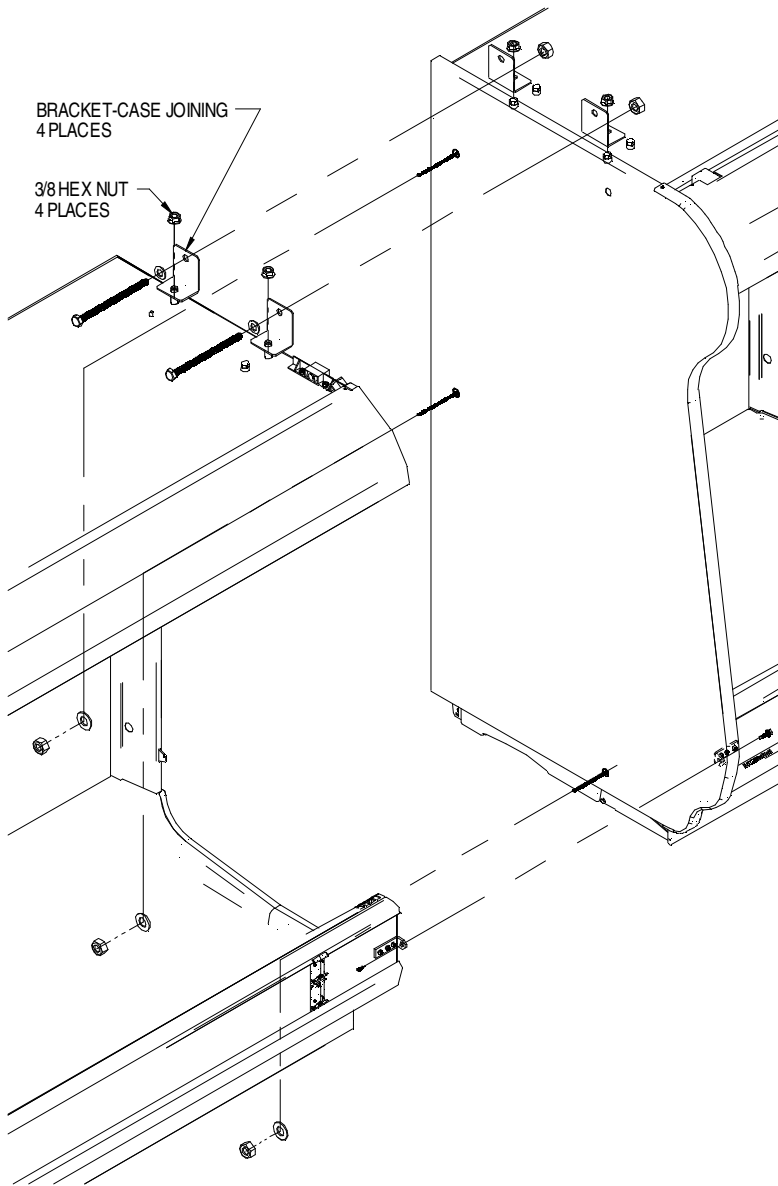
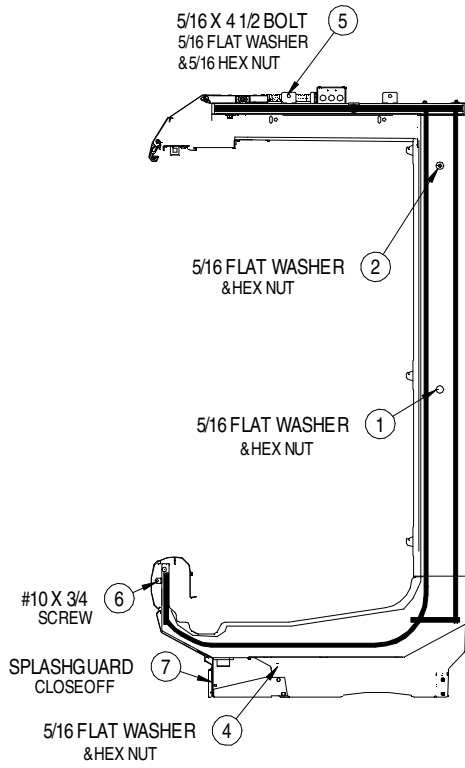

MULTI DECK (DOOR)
DIFFERENT CASE PARTITIONS

Refer to detail views

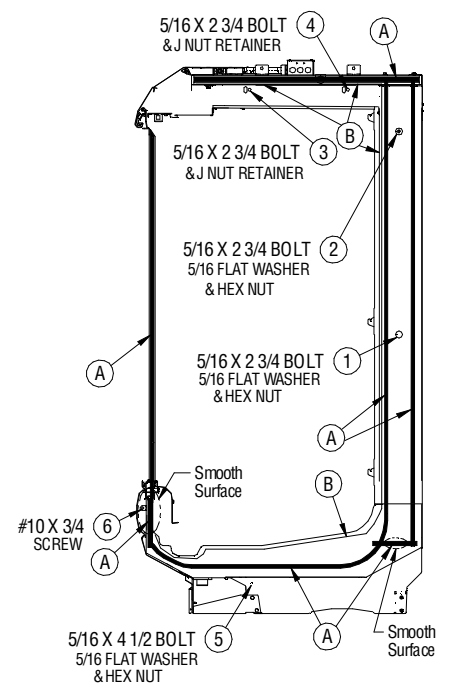
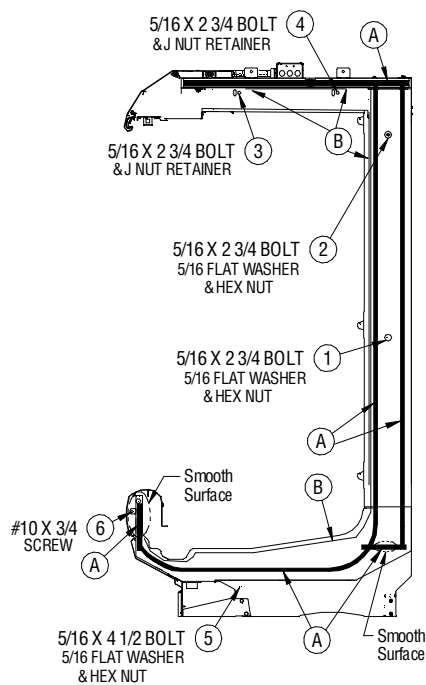
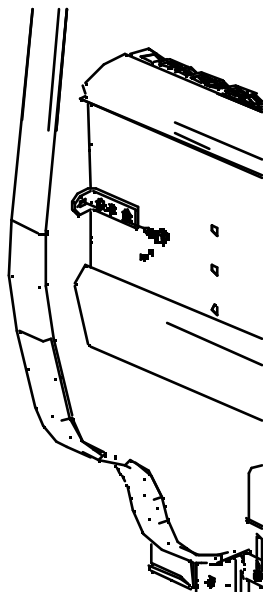
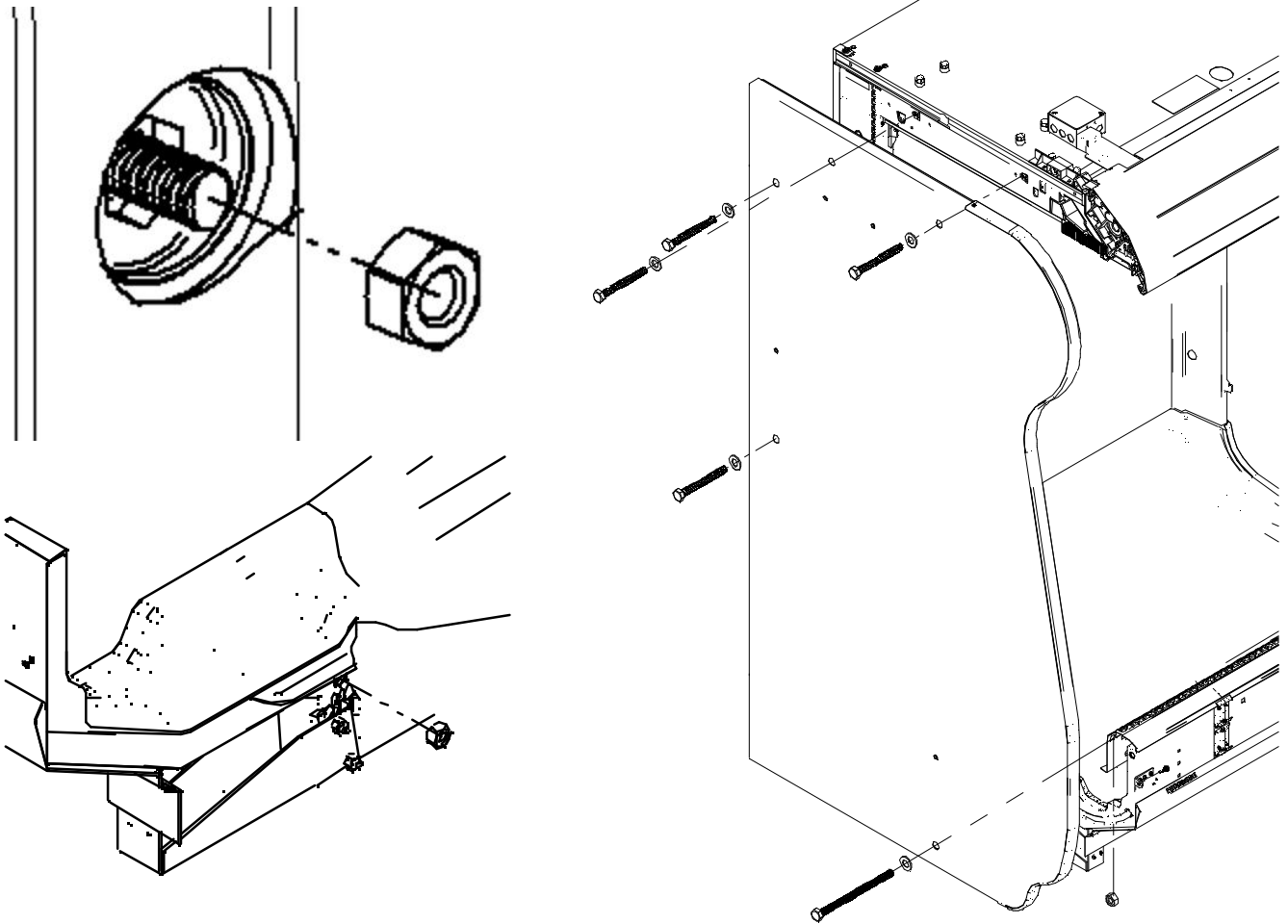

**MULTI DECK (DOOR)
DIFFERENT CASE PARTITIONS
CONTINUED**

Refer to detail views

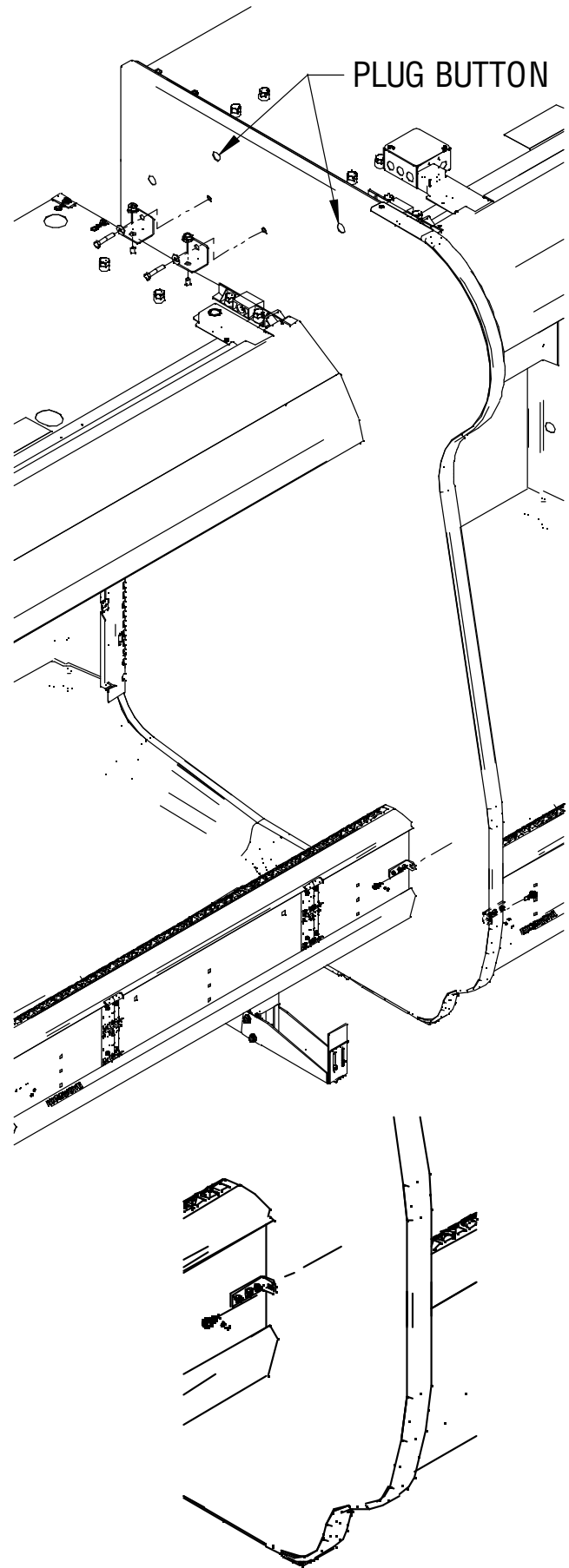
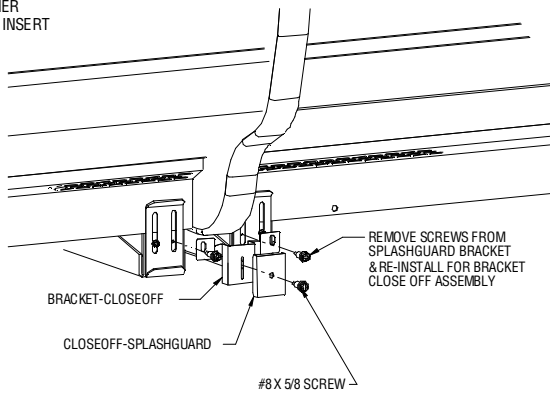
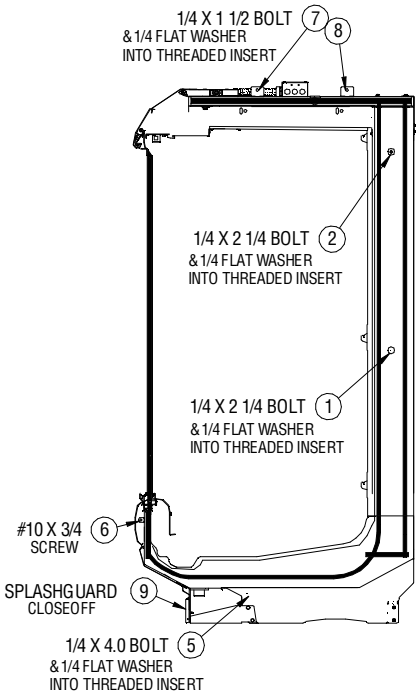
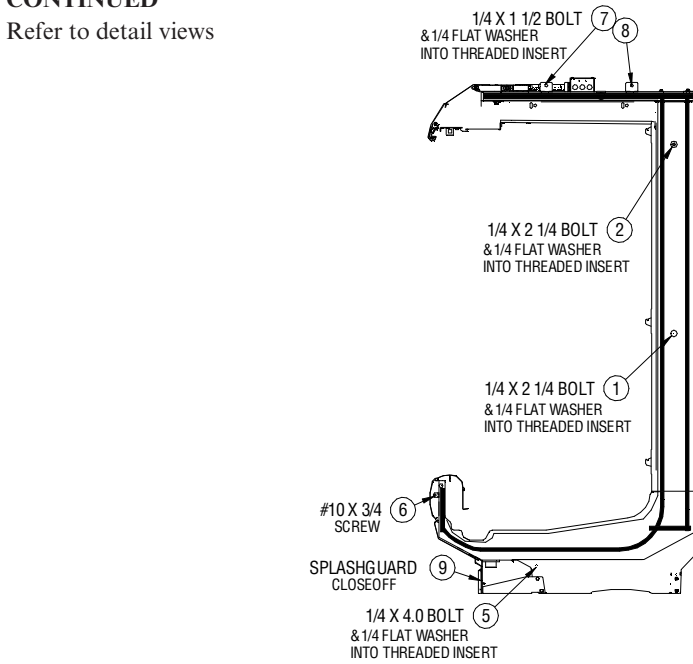

DIFFERENT CASE PARTITIONS MULTI-DECK (DOOR)
ALTERNATIVE CANOPY APPLICATIONS
CONTINUED

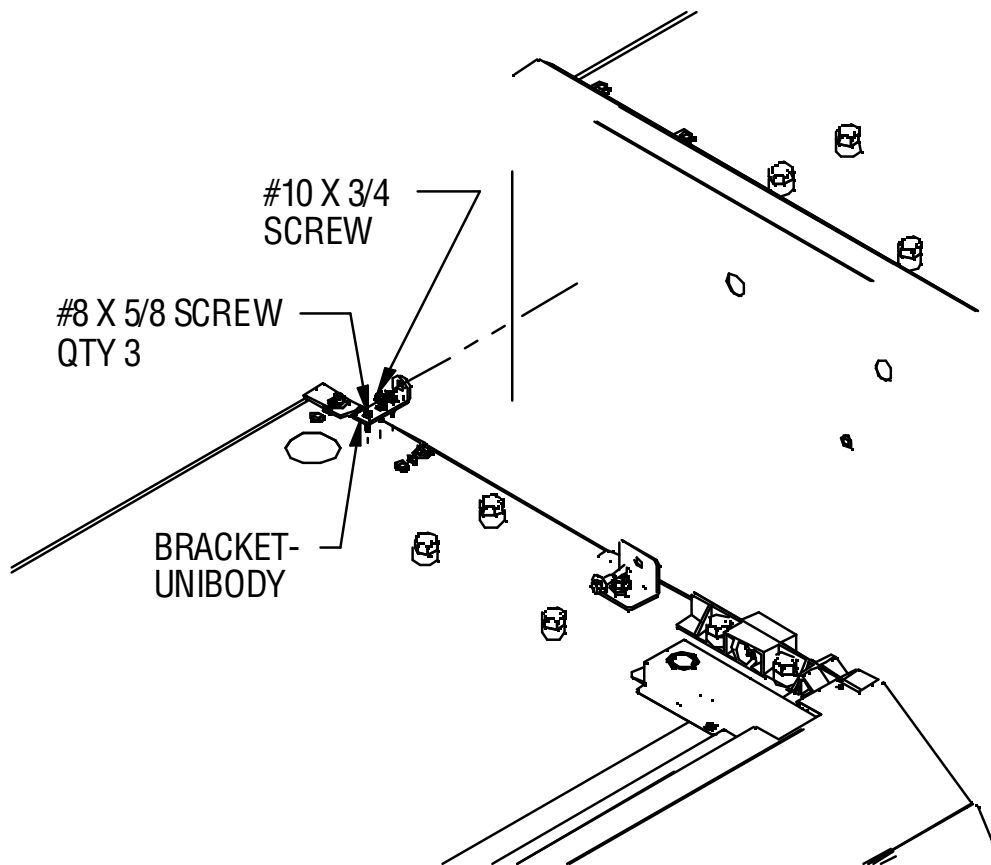
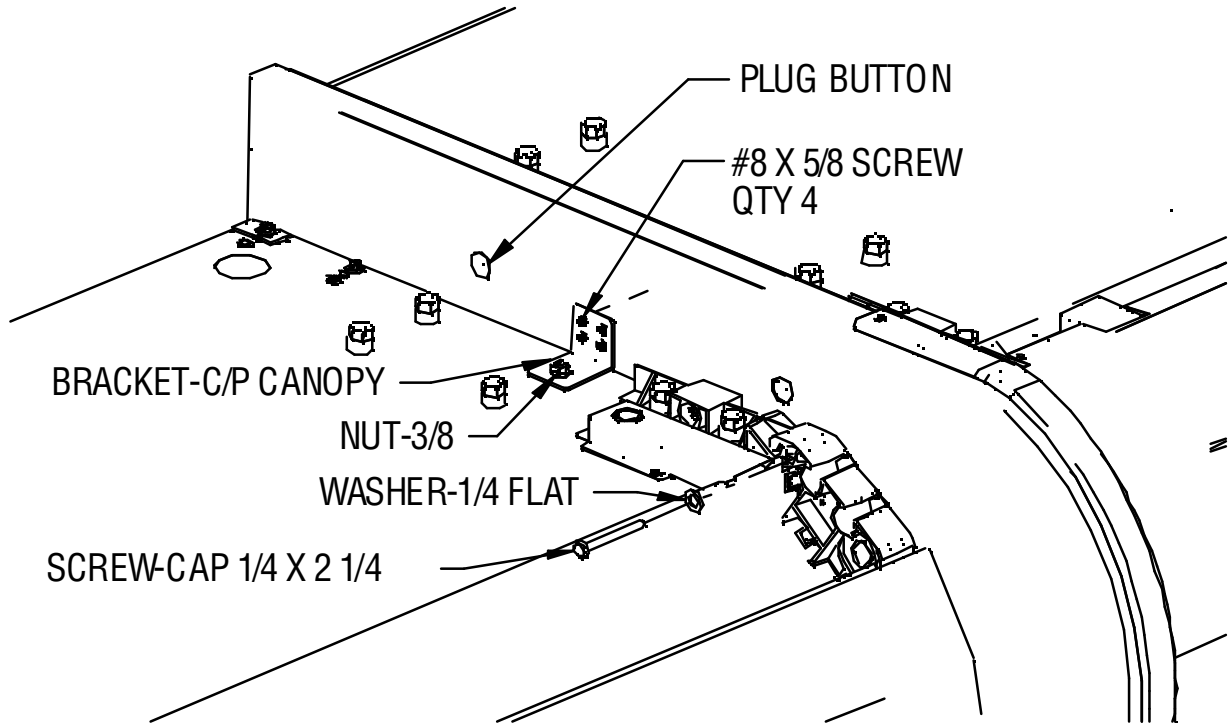

Refer to detail views





ACRYLIC PARTITION HARDWARE

Description	Multi Deck Qty/Each	Convertible Qty/Each
PARTITION-ACRYLIC	1	1
BRACKET-CANOPY	1	1
BRACKET-RETURNAIRGRILL	N/A	1
SCREWSM#8 x 5/8 HEX	3	4
SCREWMACHINE#8 x 1/2 PHILL	3	4
LOCKWASHER-#8 EXT TOOTH	3	4
NUT-#8 MACHINEHEX	3	4

Screw-Sheet Metal #8 x 5/8  

Screw-Machine #8 x 1/2 Phill  

Lockwasher-Ext Tooth #8  

Nut Machine Hex-#8  

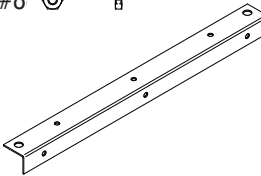
Bracket-Canopy Multideck 

Bracket-Canopy Convertible 

Bracket-Return Air Grill 

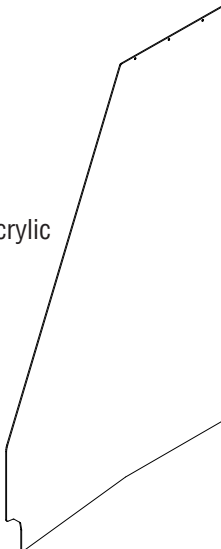
Partition-Acrylic 

**MULTI-DECK
ACRYLIC PARTITIONS**
Refer to detail views

ACRYLIC PARTITION
TO BE MOUNTED
BETWEEN TWO
CASES ATTACH
BRACKET TO ONLY
ONE CASE

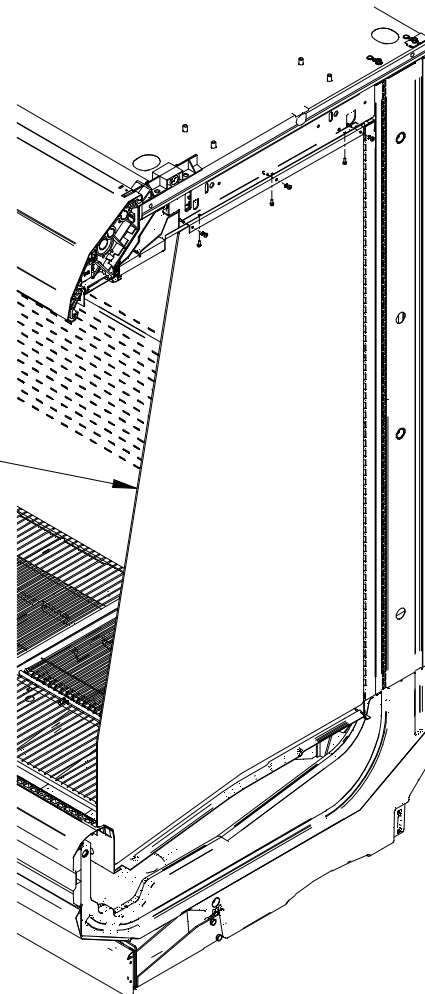

#8 X 1/2 MACHINE SCREW
#8 EXT TOOTH LOCKWASHER
& #8 MACHINE NUT
3 PLACES

3

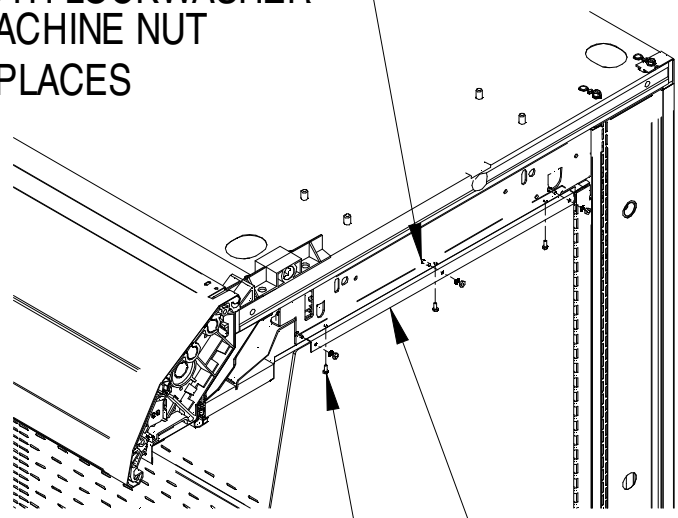

1 BRACKET-CANOPY

2 #8 X 5/8 SCREW
3 PLACES

INSTALLING BUMPERS

1. Bumpers are packed out with the case and snap onto the bumper retainer. Gaskets are factory installed in the bumper retainers to provide support for the bumpers. Do not remove the gaskets.
2. Bumper joint inserts are provided with the case to disguise joints for a lineup of cases.
3. Start at the left end of the lineup. Install 3ft starter bumper first. Refer to bumper side view illustration to ensure the bumper is orientated correctly. Place top of bumper over bumper retainer, then snap bottom of bumper into place at bottom of retainer. Position internal joint trim between the starter bumper and full-length bumper.

4. Continue installing bumper(s) until the lineup is complete. The last piece of bumper will need to be cut so that it is flush with the right end cap. Use a fine tooth saw to cut the bumper vertically at a 90° angle.

5. Ensure joint trim is positioned behind bumper at all joints to close any gaps in the lineup. Remove protective film from bumper once installation is complete.

NOTE  Bumpers come in two styles — **Ellipse and Faceted.**

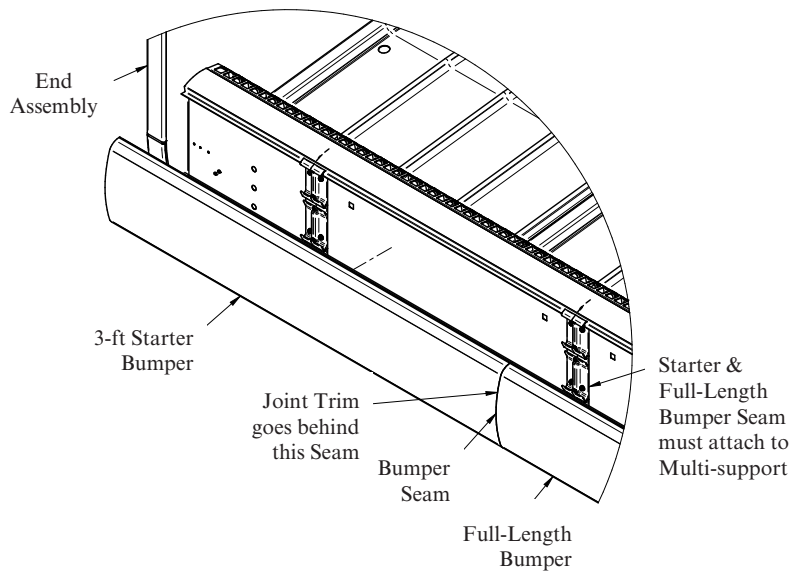
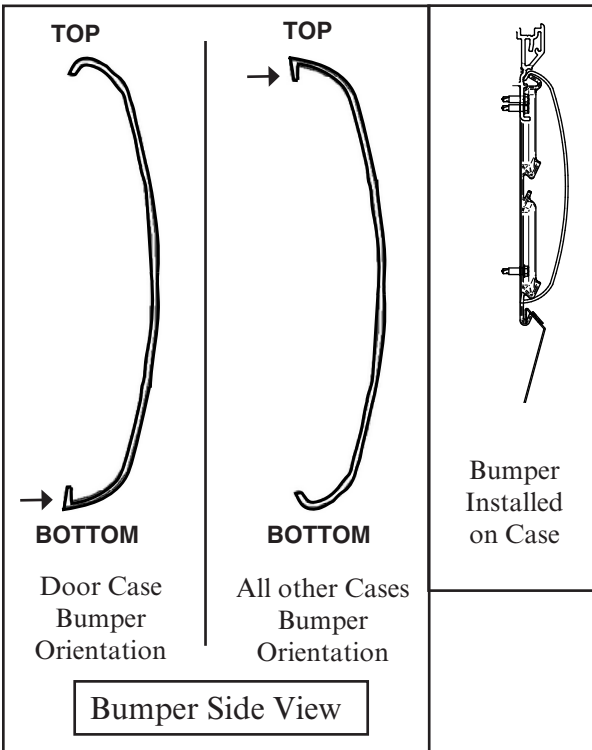
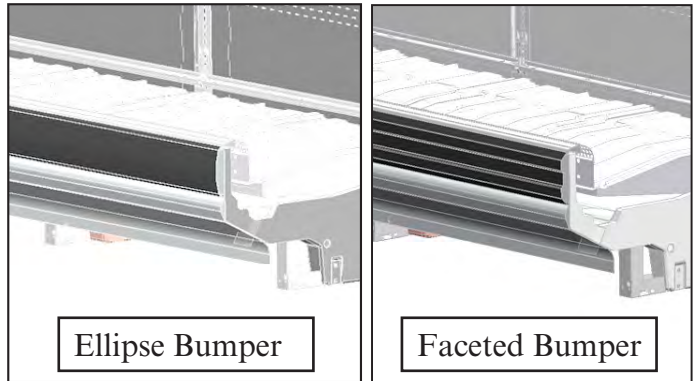

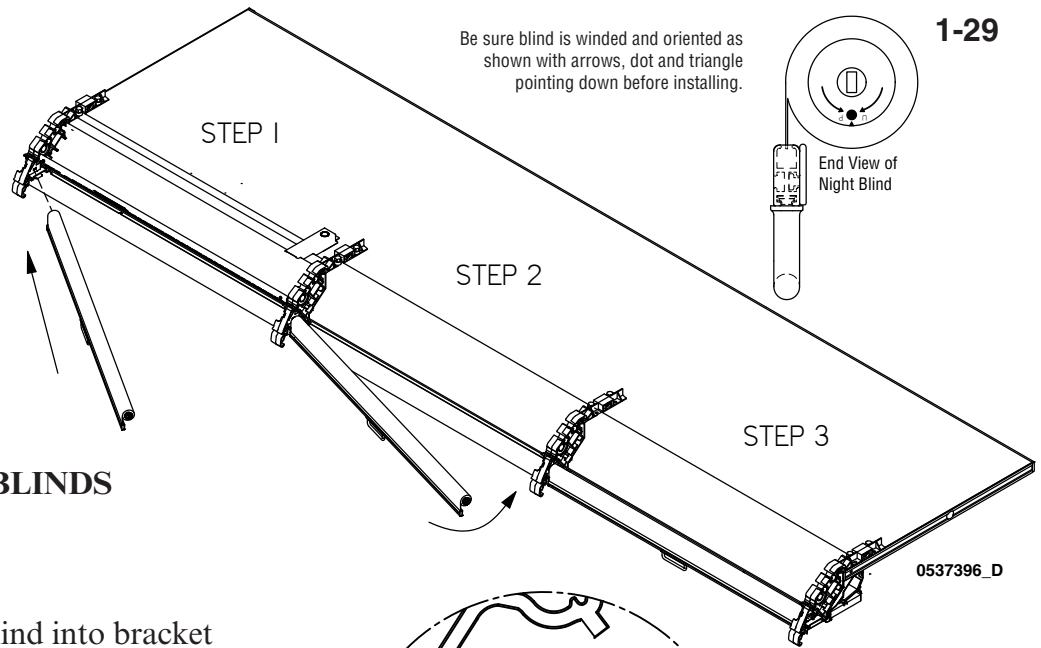

INSTALLING NIGHT BLINDS

STEP 1

Slide the lefthand night blind into bracket cutout.

NOTE Left section of case always uses the front cutout. Alternate front to back for remaining sections.

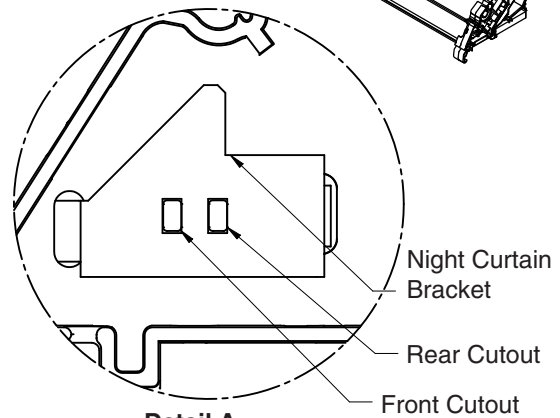

Detail A
Brackets Always on Left Side of Night Curtain

STEP 2

Swing righthand side of night blind into slot on side of canopy support arm.

NOTE Left section of case always uses the bottom slot. Alternate bottom to top for remaining sections.

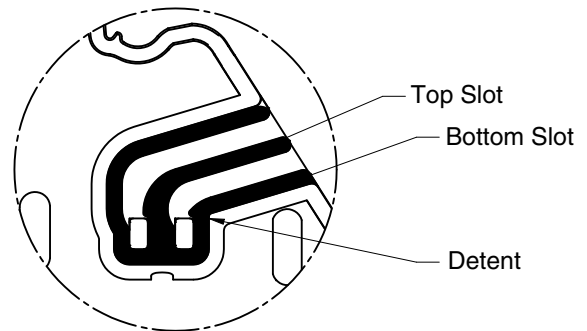

Detail B
Slots always on right side of night blind

STEP 3

Push/pull down on night blind slightly to slide pin past detent.

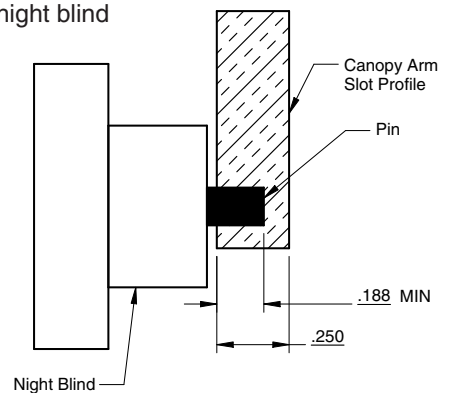

STEP 4

Check pin engagement to ensure at least 3/16" of pin is firmly in the slot.

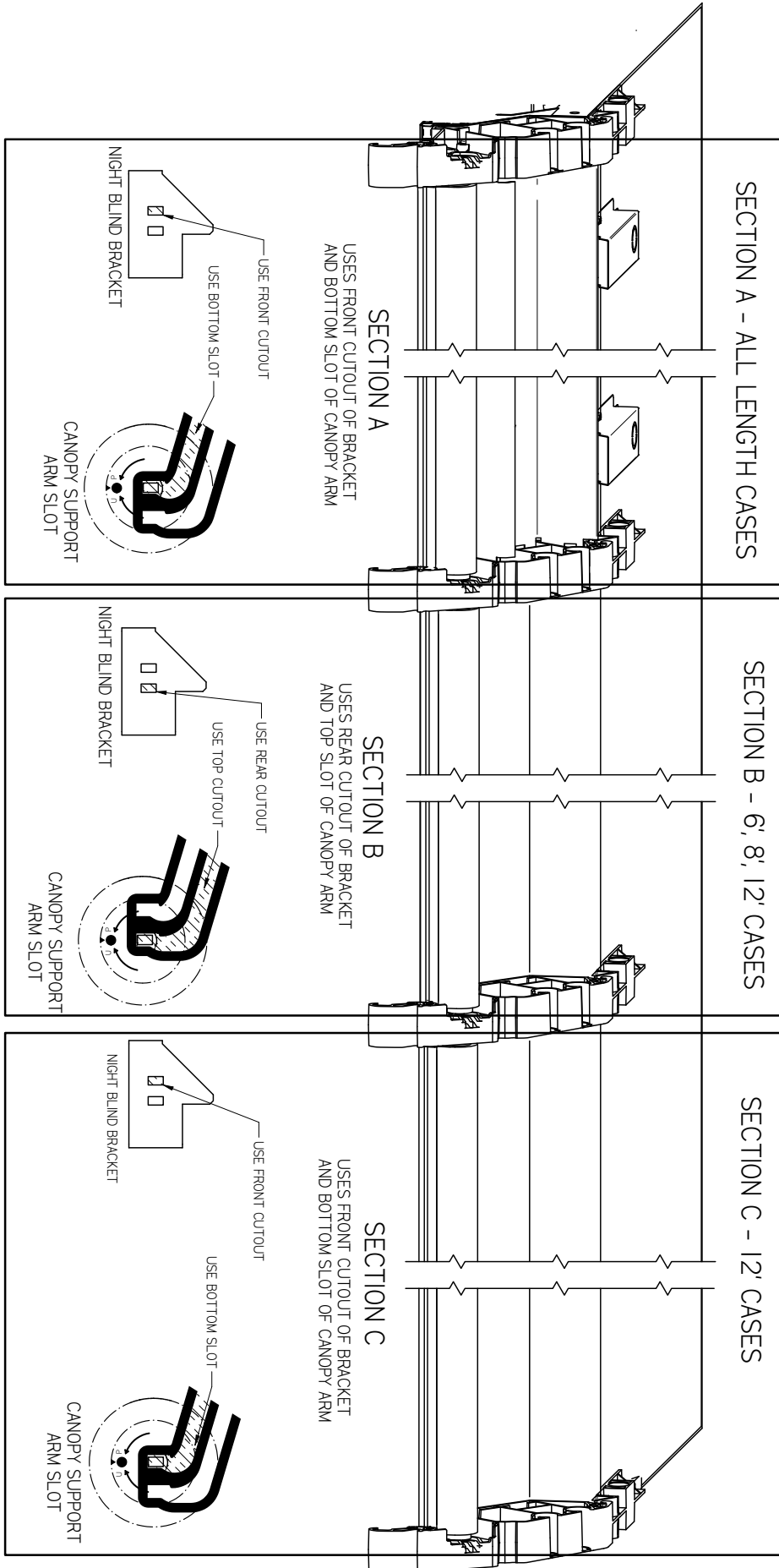

LOADING BLIND SPRING

Night blinds are delivered pre-loaded. However, if it is necessary to load night blind spring, use a wrench (part number 0477098) to twist rectangular pin on right side of night blind. Twist clockwise 14 to 15 full revolutions.

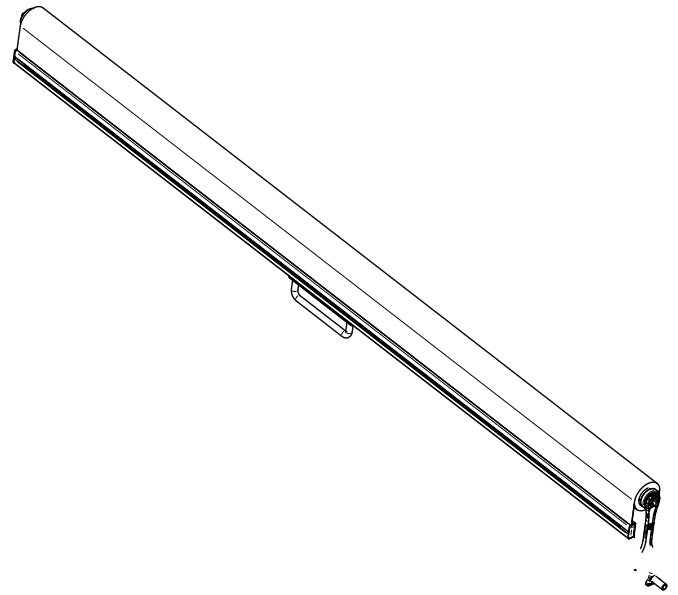

NOTE  **Keep arrow / dot / up pointed up while winding. Keep pointed down when installed.**



Reference Mark (triangle or circle) must be oriented upward when winding and downward during installation.

Image showing wrench tightening night blind

Night Blind Handle

Twist wrench clockwise for 14 to 15 revolutions

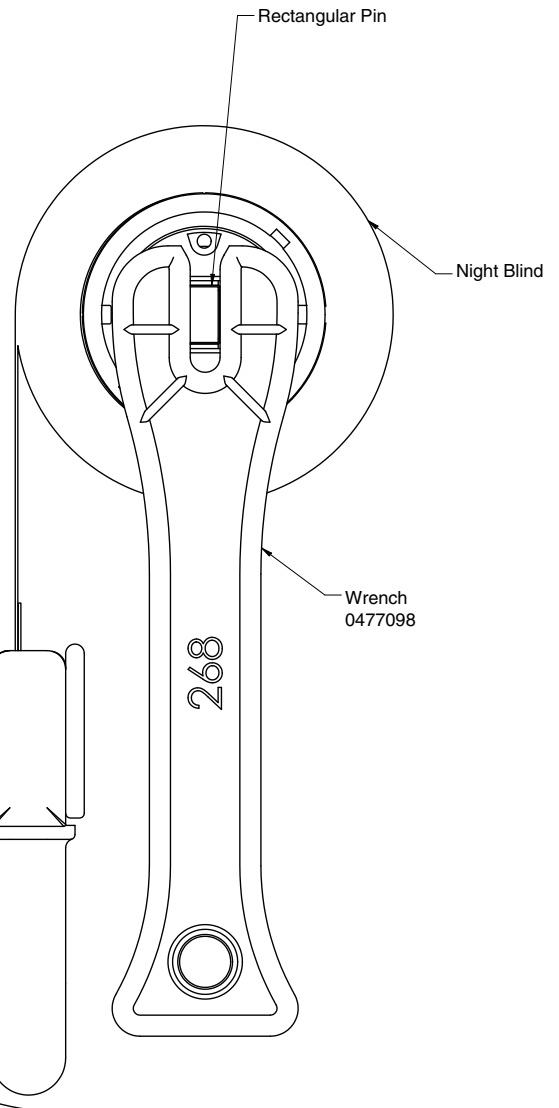

TROUBLESHOOTING NIGHT BLINDS

If night blind is not installed:

STEP 1

Only install brackets on the lefthand support arm and each center support arm.

STEP 2

On the righthand side of each arm, insert front tab of bracket into the front slot, then snap into the rear slot.

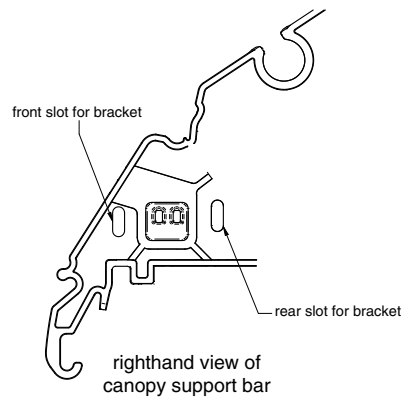
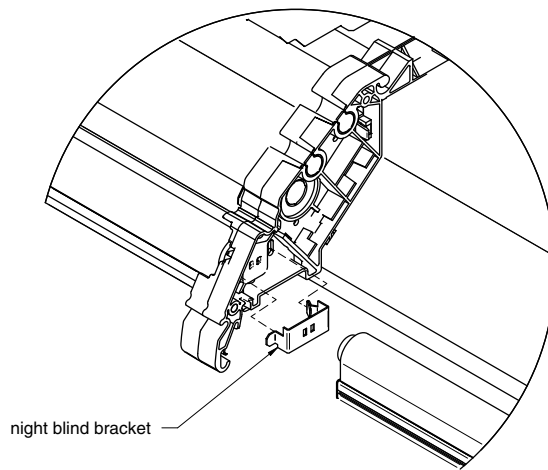

If pin is too short or rounding out canopy arm:

STEP 1

Remove night curtain from case

STEP 2

Use pliers to pull metal pin out to desired length

STEP 3

Replace night curtain into canopy

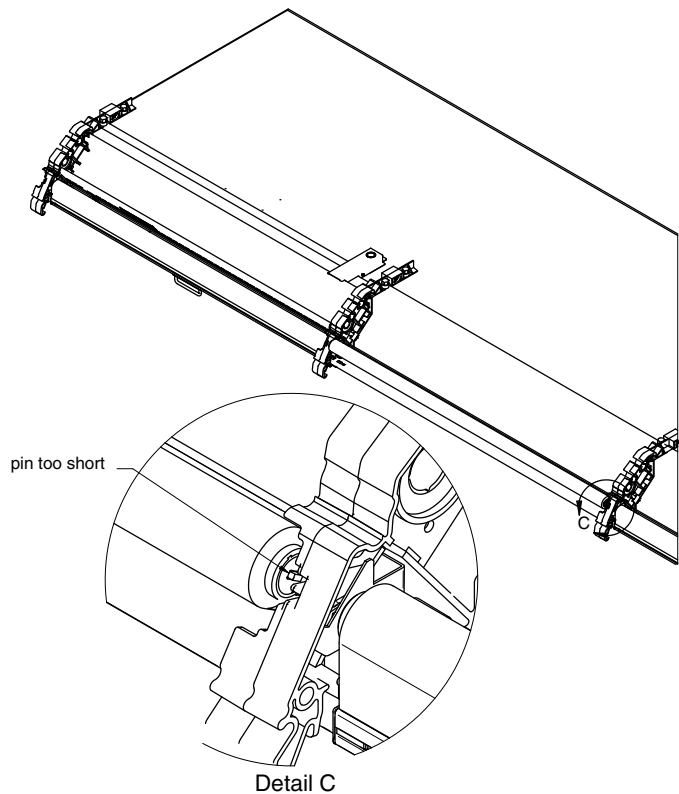

NOTE  **Keep pointed down when installed.**

ELECTRICAL / CONTROLLER / WATER / REFRIGERATION**⚠ DANGER**

- » Due to risk of ignition resulting from incorrect parts or improper service, only Hussmann authorized personnel may service this equipment. Component parts shall be replaced only with like components. FAILURE TO USE AUTHORIZED TECHNICIANS COULD RESULT IN EXPLOSION, DEATH, INJURY AND PROPERTY DAMAGE.

ATTENTION

Merchandiser must operate for 24 hours before loading product!

Regularly check merchandiser temperatures.

Do not break the cold chain. Keep products in freezer before loading into merchandiser.

Medium temperature merchandisers are designed for loading ONLY pre-chilled products.

Low temperature merchandisers are designed for loading ONLY frozen products.

**⚠ WARNING**

— LOCK OUT / TAG OUT —

- » To avoid serious injury or death from electrical shock, always disconnect the electrical power at the breaker when servicing or replacing any electrical component. This includes, but is not limited to, such items as doors, lights, fans, heaters, and thermostats.

This equipment uses a flammable refrigerant. Installation, service and repair should be done only by qualified and trained technicians in accordance with this manual.

If a leak is detected, follow store safety procedures. It is the store's responsibility to have a written safety procedure in place. The safety procedure must comply with all applicable codes such as local fire department's codes.

At minimum, the following actions are required:

- Immediately evacuate all persons from the store, and contact the local fire department to advise them that a propane leak has occurred.
- Call Hussmann and/or a qualified service agent and inform them that a propane sensor has detected the presence of propane.
- Do not let any persons back into the store until the qualified service technician has arrived and that technician advises that it is safe to return to the store.
- The propane gas used in the unit has no odor. The lack of smell does not indicate a lack of escaped gas.
- A hand-held propane leak detector ("sniffer") should be used before any repair and/or maintenance is attempted. All repair parts must be identical models to the ones they are replacing.
- No open flames, cigarettes or other possible sources of ignition should be used inside the building where the units are located until the qualified service technician and/or local fire department determines that all propane has been cleared from the area and from the refrigeration systems.

ELECTRICAL

These self-contained merchandisers have water-cooled condensers. Each 4ft of case module has a dedicated refrigeration system. For multi-deck cases, the condensing unit may be located behind interior back panels or on top of the case.

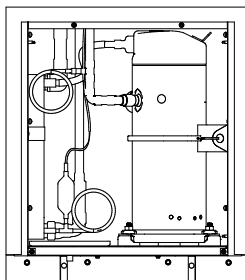

These self-contained merchandisers are controlled by the Corelink electronic control with power relays located inside the sealed box. Hussmann recommends a gateway for defrost coordination or setting the controller with the correct time on the clock, cases with open ends must have the same defrost times.

MERCHANDISER ELECTRICAL DATA

Refer to merchandiser serial plate or case data sheets for electrical information.

ELECTRICAL CONNECTIONS

All wiring must be in compliance with NEC and local codes. All electrical connections are to be made in the controller enclosure.

FIELD WIRING

Field wiring must be sized for component amperes stamped on the serial plate. Actual ampere draw may be less than specified.

ALWAYS CHECK THE SERIAL PLATE FOR COMPONENT AMPERES

⚠ CAUTION

- » Risk of Electric Shock. If cord or plug becomes damaged, replace only with a cord and plug of the same type.

⚠ WARNING

- » Merchandiser must be grounded.
- » Do not remove the power supply cord ground.

CASE ELECTRONIC CONTROLLER**⚠ WARNING****IMPORTANT!**

Disconnect electrical power before beginning any service on electrical or electronic equipment. **DO NOT** work around live electrical circuits. Make sure the machine is switched off before working on electrical connections. All operations must be carried out by qualified personnel.

Check that the supply voltage is correct before connecting devices. Never use power that differs from that indicated in the manual. Power supplies other than those specified can seriously damage the refrigeration system or other components and parts.

Separate the cables of the analogue inputs from those of the digital inputs and the serial line cables from the power cables (resistive as well as inductive), in order to prevent malfunction due to electromagnetic interference.

All system components should be obtained from Hussmann to ensure system compatibility and reliability. Make connections as short as possible, and do not wind them around electrically connected parts. When connecting loads, follow connection diagrams carefully.

Never connect the secondary of the supply transformer to the earth.

The low voltage connections must have reinforced insulation.

When using the digital inputs of the Corelink Case Controller use another transformer in order to prevent the digital inputs from malfunctioning or being damaged.

To avoid causing static discharge, do not touch the electronic components on the boards.

DO NOT use the same secondary of the controllers power. Doing so can result in damage to case controller.

DO NOT exceed the maximum current capacity of the onboard controller relays. Always verify the capacity of the output used.

DO NOT plug in accessory devices that are not approved by Hussmann.

DO NOT exceed the maximum current capacity of the onboard controller relays.

Always verify the capacity of the output used.

DO NOT plug in accessory devices that are not approved by Hussmann.

GND is Common(-), not earth ground. Do not earth ground this device.

Permitted Use

- ▶ Food Display Merchandisers
- ▶ Coolers
- ▶ Self-Contained
- ▶ Remote Cases

Improper Use

- ▶ HVAC
- ▶ Unspecified Installation
- ▶ Deviation from established Legislation and Standards

Hussmann is not responsible for misuse of device. Hussmann is not held responsible for deviation from this manual and its intended use. If you have any questions, contact your Hussmann representative for details.

In case of failure or faulty operation, send the controller back to the distributor with a detailed description of the fault.

The controller should not be used for purposes different from those described in this manual. It cannot be used as a safety device.

CASE ELECTRONIC CONTROLLER

Insight self-contained R-290 cases are controlled by a CoreLink Electronic Controller for refrigeration and defrost control and control of lights and fans. The controller is factory programmed with the required parameters to safely operate the merchandiser and maintain required product temperature. There is no need to make adjustments to the controller, however, it is recommended that the program be checked at startup. Refer to the display case data sheet for discharge air temperature, setpoint, defrost cycle and other information.



Control Operation

The case temperature is controlled by cycling the compressor ON and OFF based on the discharge air temperature. The case is divided into modular control sections: 4 ft cases have 1 control section, 6 ft and 8 ft cases have 2 control sections, 12 ft cases have 3 control sections.

The discharge air temperature sensor is located above the honeycomb at the center of each control section. Compressors are cycled based on its own sensor in 2 control temperature. The second compressor has a 5-second delay at each startup to prevent excessive startup current. The discharge air temperature varies by case model and application. Refer to the technical data sheets for more information on specific case settings. The discharge air temperature may be modified for specific product temperatures. There are two methods for accessing CoreLink:

The wireless connection kit enables connection to the CoreLink Web UI on a connected smart device, or users can use Building Automated System (BAS) to change parameters from a single, central location. For an explanation of wireless connection at the case, consult the CoreLink user manual under Web User Interface Section.

NOTE: Individual cases may be designed to run at a specific temperature setting and may not perform well at lower or higher settings, depending on such things as condenser water temperature, ambient conditions, etc.

Defrost is time-initiated, and is programmed with the correct number of defrosts per day and the correct termination. Cases are time terminated. The start time for defrost must be programmed using BAS.

Additional Safeties

CoreLink incorporates additional safeties to protect the case from critical failures in an MDS installation. These safeties may, or may not be installed, depending on case model. The following safeties (see next page) protect the compressors in the event of refrigerant loss, water system failure, or any other blockages of the heat exchanger. These safeties will be displayed as an alarm on the CoreLink WebUI, and the compressor will shut off. Depending on the severity and length of time of the alarm condition, the CoreLink alarm may cause the compressor to lock out and not re-start, and the alarm will need to be cleared after the cause of failure is diagnosed and repaired.

Instructions to clear the alarm and re-start the compressors will be given in the Diagnosis > Fault Sequence > Fault Code (Click on link for Fault Details popup). Generally, a reboot of the controller once the failure mode is discovered and repaired will clear the lockout.

Compressor internal suction pressure protection

The controller will alarm and disable the compressor output when a refrigerant loss occurs. In the event of a refrigerant loss, the compressor will shut off and lock out. After the condition is repaired, the alarm will be cleared when the controller is rebooted.

Compressor Discharge Temperature Safety

The controller will alarm and disable the compressor output until the temperature falls below threshold.

Compressor Pressure Safety Switch

The controller will disable compressor output when the pressure safety switch is activated. Compressor will resume operation when the safety switch is deactivated.

Compressor Run-time Safeties

Additional run-time safeties are incorporated to protect the compressor and MDS products.

HACCP

This value can be configured to be reported as the value of a choice between a few different sensor values. This can be configured under Config > Refrigeration > Temperature Sensors > HACCP Sensor.

Application

The application will have the option to support up to three separate zones. To maintain case temperature, the application will use discharge air temperatures and safeties to manage cold operations.

Internal Web Server

The CoreLink case controller features a user interface that can be accessed by web browser. This Web UI can be accessed by in store network via windows computer or with a wireless link device that can be viewed by technician through smart devices.

Data Logging

The case control application has internal logging for each sensor along with critical operation data. Data is available for local download.

- › 2-minute intervals
- › 14-day capacity
- › Advanced analytics; web user interface
- › CSV format with 15 critical data points

Onboard data logging allows user to review performance data from the past week. User can see Min/Max/Average data along with saving data sets and importing data sets for view.

Factory Restore

The CoreLink application has a configuration file with the complete and optimized default case settings.

Anytime a user wants to default to factory settings they can simply access the user interface and force a factory reset.

Save / Load Feature

The CoreLink Case Controller is setup from the factory with a specific product configuration when a customer purchases a display case.

This specific configuration is hardcoded into the controller and is the factory default file. Also included are three user presets that a user can save or load custom configuration settings. These settings allow customers to make small tweaks in the field that can improve performance or target temperatures.

Standalone Operation

Controller is configured from the factory to run as a standalone controller. Field network integrations are done to provide additional capabilities to the controller. In case of network failure of BAS managing additional control functions, controller will default to its standalone settings and regulate display case until network connection is restored.

In case of network failure to building automation system managing case setpoints, the controller will default to program settings in internal memory and continue to regulate display case until network connection is restored.

Bios Version: 2020052000
 Web UI Version: 2.3.0
 Application Version: 3.4.0



4 DIN Devices

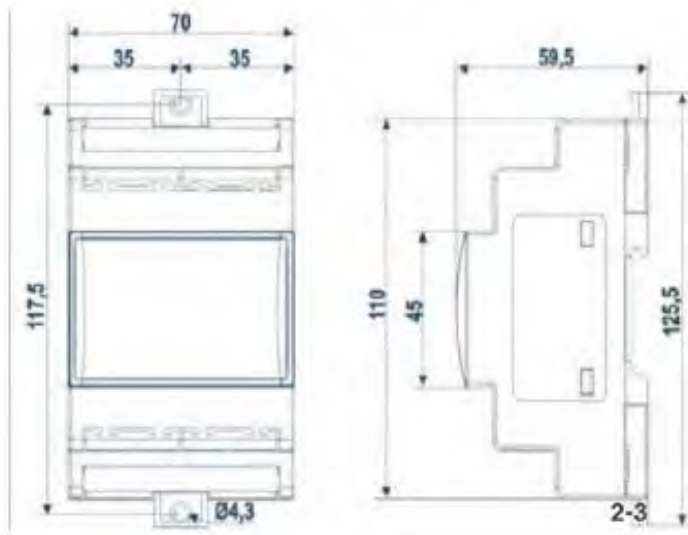

LED Indicators

Programming Sequence USB Flash Drive	
Yellow Status LED	Time
Flashing	10 secs
Illuminated Solid ON	2 min 10 secs
Flashing	25 secs
Dim	10 secs
Illuminated Solid ON	30 secs
Reboot	See Boot Sequence

Boot Sequence	
Yellow Status LED	Time
Off	5 secs
Dim	10 secs
Illuminated Solid ON	30 secs
Blinking / Normal Operation	Indefinitely



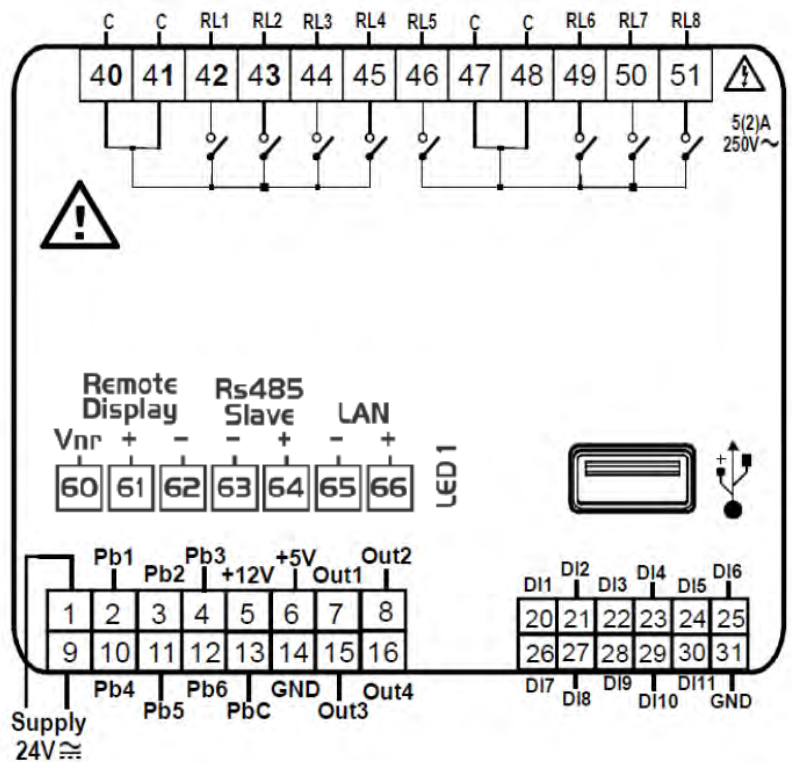

Status Yellow LED
 Power Indicator Green LED

Corelink Case Controller IO

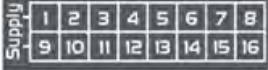

Digital Inputs

Connector	Description
	Connector for 24Vac/dc power supply Analogue inputs (Pb1 - Pb6), Pbc) Additional Power (+5Vdc, +12Vdc, GND) Analogue outputs (Out1 - Out4, GND)
	24Vac/dc digital inputs (DI1 - DI11, GND) Note: Not a dry contact switch, power supply 24Vac or 24Vdc required to activate switch If using 24Vdc, pin 31 is GND
	Network Connector Hussmann Controller Display, maximum 1 terminal per Corelink RS485 Slave connector Serial port (LAN or RS485)
	USB port for downloads (BIOS, application, configuration files, remote display applications network configurations, website) and uploads (log files) Connection with the computer via a USB-ETHERNET converter Connection with wireless connection kit
	Digital relay outputs 4 NO relays, 2 common Note: Pin 40,41 common to pins 42,43,44,45
	Digital relay outputs 4 NO relays, 2 common Note: Pin 47,48 common to pins 46,49,50,51

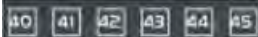
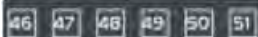
Input No.	Type of Input	Description
		
Connector for 24Vac/dc power supply		
Analogue inputs (Pb1 - Pb6), Pbc)		
Additional Power (+5Vdc, +12Vdc, GND)		
Analogue outputs (Out1 - Out4, GND)		
1	Supply	Reference "-" /GND (24Vac or 24Vdc)
2	Pb1	Config analog input (NTC, PTC, 0 - 20mA, 4 - 20mA, 0 - 10V, 0 - 1V, 0 - 5V, DI, CPC, CPC High)
3	Pb2	Config analog input (NTC, PTC, 0 - 20mA, 4 - 20mA, 0 - 10V, 0 - 1V, 0 - 5V, DI, CPC, CPC High)
4	Pb3	Config analog input (NTC, PTC, 0 - 20mA, 4 - 20mA, 0 - 10V, 0 - 1V, 0 - 5V, DI, CPC, CPC High)
5	(+12V)	Additional power +12Vdc
6	(+5V)	Additional power +5Vdc
7	Out1	Analogue output (0 - 10V, 4 - 20mA, Relay)
8	Out2	Analogue output (0 - 10V, 4 - 20mA, Relay)
9	Supply	Reference "+" power supply (24Vac or 24Vdc)
10	Pb4	Config analog input (NTC, PTC, 0 - 20mA, 4 - 20mA, 0 - 10V, 0 - 1V, 0 - 5V, DI, CPC, CPC High)
11	Pb5	Config analog input (NTC, PTC, 0 - 20mA, 4 - 20mA, 0 - 10V, 0 - 1V, 0 - 5V, DI, CPC, CPC High)
12	Pb6	Config analog input (NTC, PTC, 0 - 20mA, 4 - 20mA, 0 - 10V, 0 - 1V, 0 - 5V, DI, CPC, CPC High)
13	PbC	Common analogue inputs (NTC, PTC, DI, CPC, CPC High)
14	GND(-)	Additional power reference 5Vdc and 12Vdc, analogue inputs (0 - 20mA, 4 - 20mA, 0 - 10V, 0 - 1V, 0 - 5V), analogue outputs. Note: Pressure sensors GND reference terminate
15	Out3	Analogue output (0 - 10V, 4 - 20mA, Relay)
16	Out4	Analogue output (0 - 10V, 4 - 20mA, Relay)
		
24Vac/dc digital inputs (DI1 - DI11, GND)		
Note: Not a dry contact switch, power supply 24Vac or 24Vdc required to activate switch		
If using 24Vdc, pin 31 is GND		
20	DI1	Digital input 24Vac/dc
21	DI2	Digital input 24Vac/dc
22	DI3	Digital input 24Vac/dc
23	DI4	Digital input 24Vac/dc
24	DI5	Digital input 24Vac/dc
25	DI6	Digital input 24Vac/dc
26	DI7	Digital input 24Vac/dc
27	DI8	Digital input 24Vac/dc
28	DI9	Digital input 24Vac/dc
29	DI10	Digital input 24Vac/dc
30	DI11	Digital input 24Vac/dc
31	GND(-)	Reference "-" for digital inputs from 1 to 11 (Note: Dry Contacts N/A, Source Required)
		
Digital relay outputs		
4 NO relays, 2 common		
Note: Pin 40,41 common to pins 42,43,44,45		
40	C	Common relays 1,2,3 and 4 (MAX 10A)
41	C	Common relays 1,2,3 and 4 (MAX 10A)
42	RL1	Relay normally open contact
43	RL2	Relay normally open contact
44	RL3	Relay normally open contact
45	RL4	Relay normally open contact
		
Digital relay outputs		
4 NO relays, 2 common		
Note: Pin 47,48 common to pins 46,49,50,51		
46	RL5	Relay normally open contact
47	C	Common relays 1,2,3 and 4 (MAX 10A)
48	C	Common relays 1,2,3 and 4 (MAX 10A)
49	RL6	Relay normally open contact
50	RL7	Relay normally open contact
51	RL8	Relay normally open contact

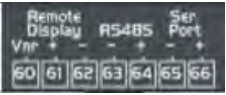
		Network Connector Hussmann Controller Display, maximum 1 terminal per Corelink RS485 Slave connector Serial port (LAN or RS485)
60	Remote Display	Connection for Hussmann Case Display remote terminal (Vnr)
61	Remote Display	Connection for Hussmann Case Display remote terminal (+)
62	Remote Display	Connection for Hussmann Case Display remote terminal (-)
63	RS485 Slave	RS485 Slave connection (-)
64	RS485 Slave	RS485 Slave connection (+)
65	LAN	LAN Connection (-)
66	LAN	LAN Connection (+)

First Power

The CoreLink case controller requires roughly 45 seconds to boot before any regulation will begin. At the end of the boot cycle you will probably notice the case lights will illuminate and cases equipped with night curtains will open to the default position.

Micro-Distributed Operation

The zones are controlled by a combination of Air Discharge sensors. These sensors are used to regulate refrigeration around Setpoint + Deadband. The average of those sensors will call compressors ON/OFF together. Additional time delays are incorporate to stage compressors.

Application

All parameters are accessible from the controllers website or BAS system. To review settings or make adjustments please refer to the connection methods listed in this manual.

No display is provided at the case unless optional

Refrigeration

Users can find typical settings in the refrigeration menu of website. Case temp can be adjusted from here.

Defrost

CoreLink will manage defrost per its own defrost schedule or from external source such as BAS system for defrost coordination. Users can find typical settings in the defrost menu of website.

How to connect to CoreLink Case Controller

Wireless Connection

Components Required

The following items are required for first time connection:

Wireless Access Point

- One Wireless Connection Kit - PN 3053767
- One Computing Device
 - Smartphone / Mobile
 - Tablet
 - Laptop

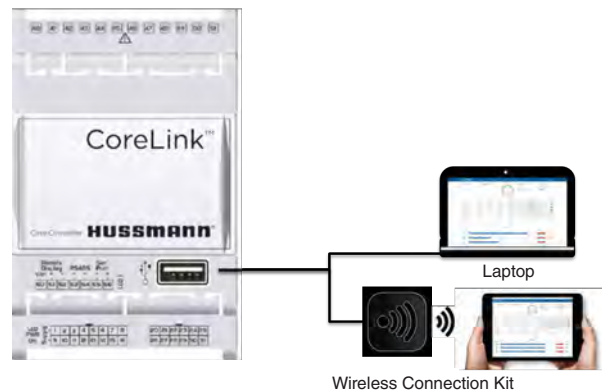

ATTENTION CONTRACTOR!
This device must not leave the store.

Connect the CoreLink with Wireless Access Point

Step 1

Connect your wireless router connection kit to the CoreLink USB port.

Step 2

Wait until the router boots up (about 30 seconds). Next, open your laptop/tablet/phone wireless network connection panel and use the default Wi-Fi Network/SSID Name and Network Key/Password noted below. These are also printed on the wireless connection kit.

Wireless Network Name/SSID:

HSM_CORELINK_AP

Network Key / Password:

HussmannCL1234

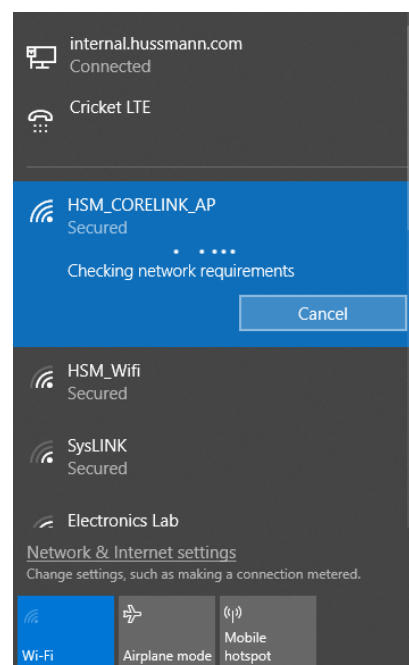

Step 3

Launch a web browser

- Safari
- Google Chrome
- Mozilla Firefox
- Microsoft Edge
- Opera
- Internet Explorer (Not Recommended)

Note: Clear cache to see latest Web UI Version. If your browser is still not working, please try the other browsers before reporting an issue.

Step 4

Enter controllers IP into the **Address/Search** Bar of your browser.

Default – 192.168.0.250

Other – **Review Store Network Chart**

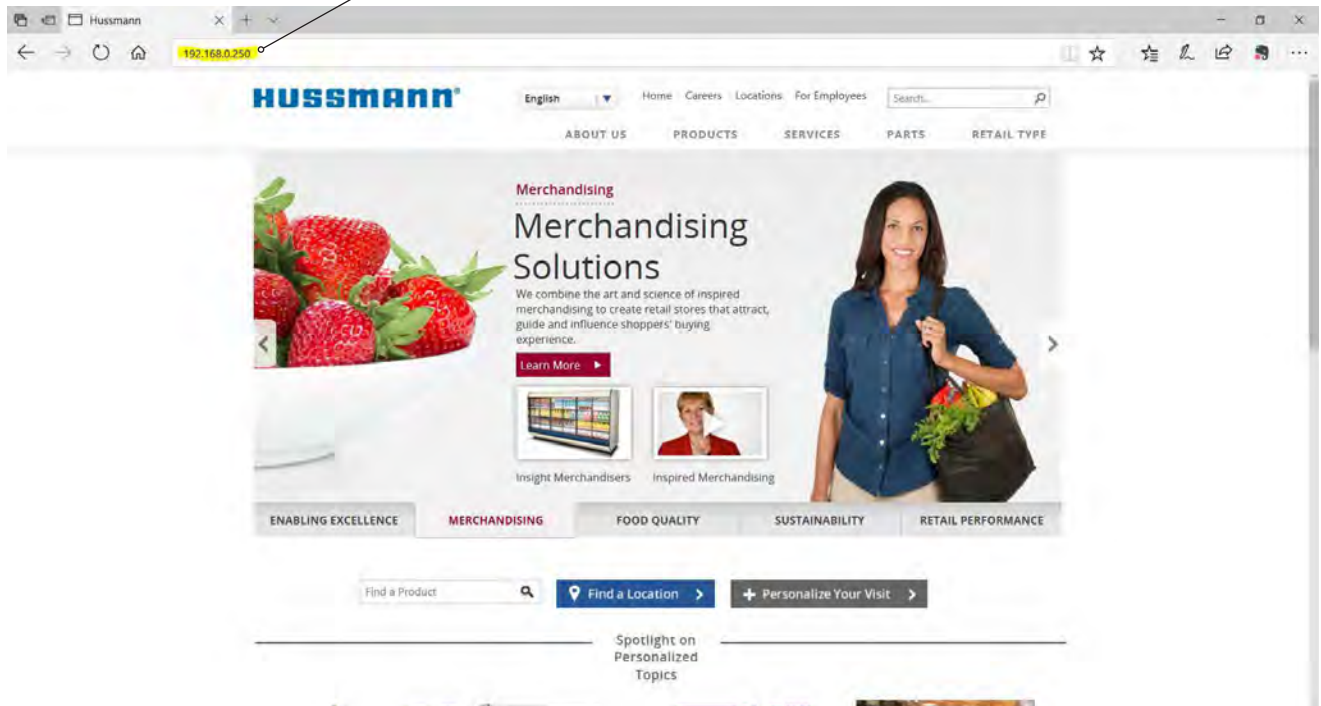

Step 5

The controller login page will appear. Enter log in information as noted below.

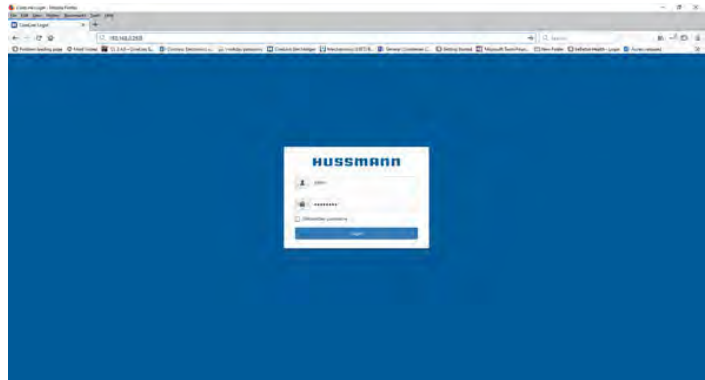

SW version >= 2.4.0	All Previous Versions
Level 1 User Name: user Password: Hussmann	Level 1 User Name: Hussmann1 Password: Hussmann
Level 2 User Name: service Password: Hussmann1234	Level 2 User Name: Hussmann2 Password: Corelink1234
Level 3 User Name: commission Password: Corelink4321	Level 3 User Name: Hussmann3 Password: Corelink4321
Admin Not Available	Admin User Name: admin Password: Hussmann

See page 9 for dashboard screen that is displayed after proper login

Direct Wired Connection

- One RJ-45 Ethernet to USB adaptor (Details Below)
- One RJ-45 Ethernet Cable
- A laptop with an RJ-45 Ethernet port

USB to Ethernet Adaptors

Approved RJ-45 Ethernet to USB adaptor

Best Option (Amazon Prime)

AmazonBasics USB 2.0 to 10/100 Ethernet LAN Network Adapter
Model: AE2233X2

Found Locally (Best Buy)

Insignia - USB 2.0-to-Ethernet Adapter – White
Model: NS-PU98505 | NS-PU98505-C

Others

Plugable USB 2.0 to 10/100 Ethernet LAN Network Adapter
Model: USB2-E100

Belkin USB 2.0 Ethernet Adapter LAN Network Adaptor
Model: F4U047bt

Note: Adaptors in the list above have been approved for use with CoreLink. Some adapter versions may not work with this equipment. The use of other adaptors is at the user's own risk.



Model: AE2233x2



Model: NS-PU98505 | NS-PU98505-C

Connecting to CoreLink - Direct Wired Connection

Step 1 - Connect laptop with RJ-45 ethernet cable/USB adaptor to CoreLink Case Controller

Step 2 - Change laptop network settings – open laptop network settings, right click **Ethernet**, select **Properties**.

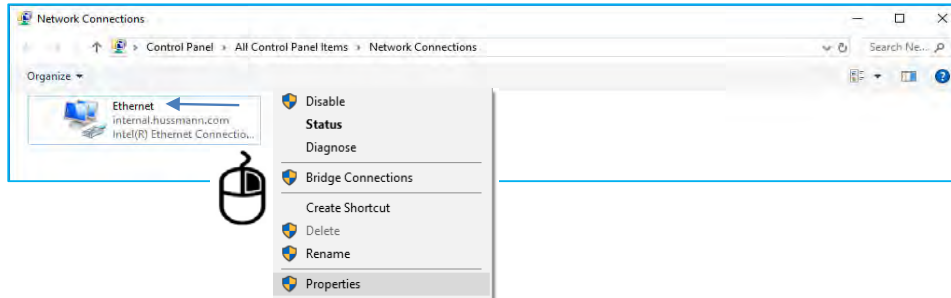

Step 3 - Select **Internet Protocol Version 4 (TCP/IPv4)**

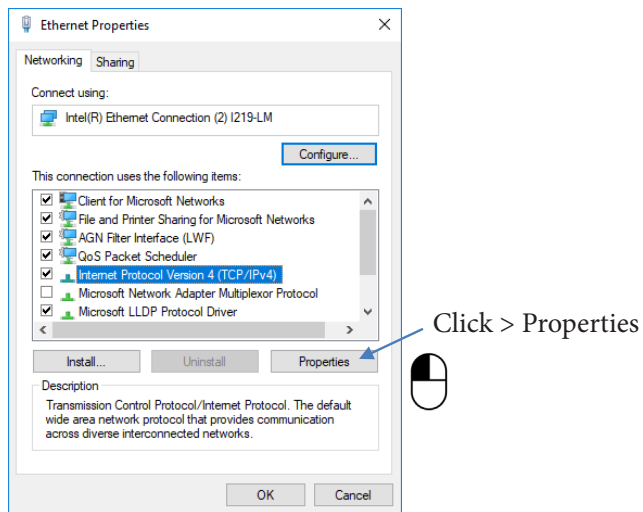

Step 4 - Enter IP address and subnet mask
Internet Protocol Version 4 (TCP/IPv4) Properties

IP Address: 192.168.0.249
Subnet mask: 255.255.255.0

The laptop computer now has a static IP assigned that is compatible with the CoreLink Network.
Click > OK

Note: Changes to your ethernet port settings might affect normal connection to the internet with your personal laptop.

To revert ethernet settings, repeat Steps 1-4.
Select > **Obtain IP address automatically** button on the general tab of the dialog box shown in the illustration at right.
Click > OK

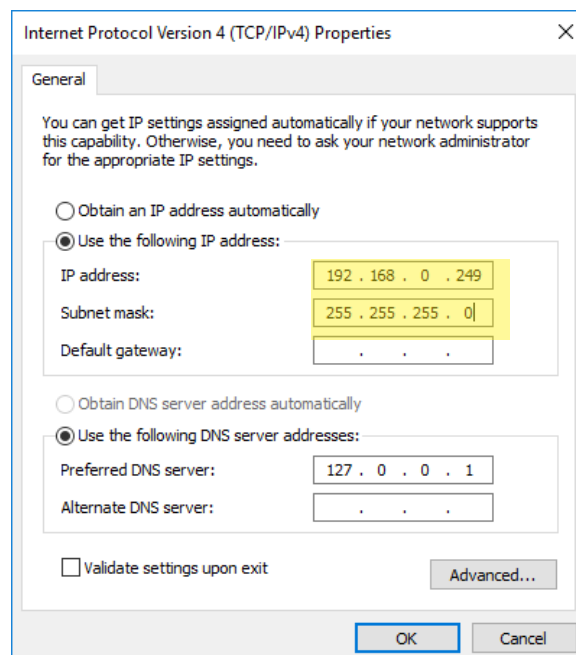

Successful Connection to CoreLink

Step 5

If connection is established to the CoreLink Case Controller a Hussmann launch screen should appear. Username and password case sensitive.

See page 5 for username/password combinations

Congratulations, you are now connected to Corelink

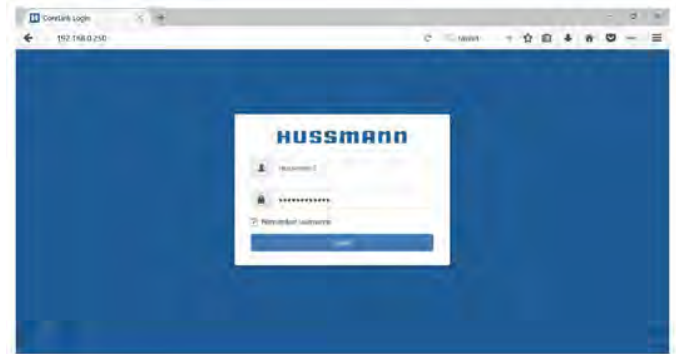

After logging in, the CoreLink Dashboard is displayed.

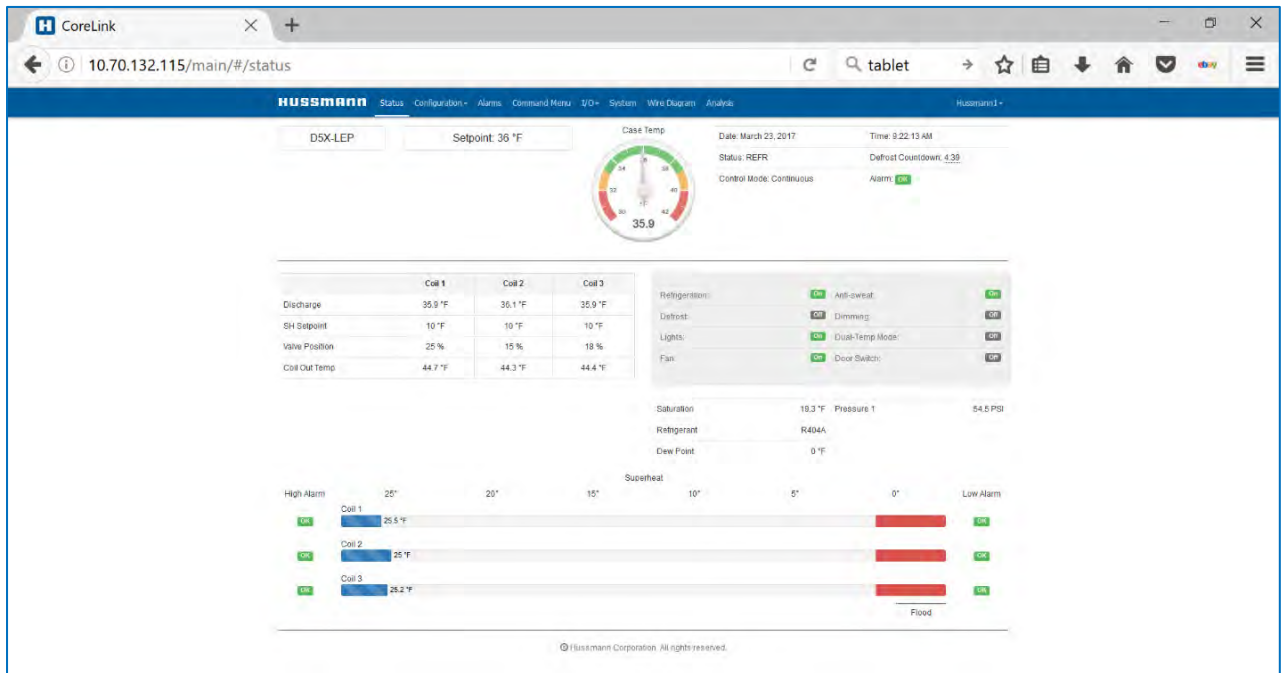

How to connect to CoreLink Case Controller in Store Network

Custom Store Network

When visiting a store site, the technician might notice the USB to Ethernet adaptors installed and connected to RJ-45 ethernet cable at the CoreLink Case Controllers. The store likely has a custom CoreLink Case Controller network with all cases connected directly to an ethernet switch or multiple ethernet switches. To access these controllers, please consult the refrigeration service contractor, or Hussmann Representative.

Technicians will need to obtain details of the network setup. Some networks may only be accessed through direct wire connection and others may have Wi-Fi available onsite. Username and password will be needed to make connection to this network much like the access point instructions above.

Technicians will also need to know the IP addressed assigned to each case circuit. In this scenario each CoreLink Case Controller will have a unique IP address assigned. Technicians will only be able to gain access to the internal Web UI with the correct provided IP address.

Once connected to the network the technician will be able to access any of the controllers connected to the network.

COMMON PROBLEMS

Clearing Cache

Try clearing your browser’s cache. If the Web UI has been revised you may need to clear your browser’s cache in order for the Web UI to work correctly and see new updates.

If the CoreLink login screen does not appear after typing in the web address, first check that hardware connections or wireless connection are correct.

If connections are good and devices power up, please check mini router settings by logging into the routers Web UI.

For cable setups, please review your computer’s network settings.

If ongoing problems continue, please contact your local IT Department or Hussmann Help Center.

Web browsers are updated on a continuous basis. Information presented below is subject to change. When in doubt, search the internet for up-to-date instructions for how to clear history for the web browser you are using.

Web Browser	Clearing Web History Cache
Google Chrome (Android)	<ol style="list-style-type: none"> 1. Open Chrome. 2. On your browser toolbar, tap “More”. 3. Tap History, and then tap Clear browsing data 4. Under “Clear browsing data,” select the checkboxes for Cookies and site data and Cached images and files. 5. Use the menu at the top to select the amount of data that you want to delete.
Fire Fox Mozilla	<ol style="list-style-type: none"> 1. Click the menu button, choose History, and then Clear Recent History.... 2. Select how much history you want to clear: Click the drop-down menu next to Time range to clear to choose how much of your history Firefox will clear.... 3. Finally, click the Clear Now button.
Safari (Apple/Mac)	<ol style="list-style-type: none"> 1. Click Safari in the upper lefthand side of your screen. In the menu that appears, click Preferences. 2. In the window that appears, click the Privacy Tab. Click the button Remove All Website Data.... 3. Click Remove Now in the pop up window that appears.
Microsoft Edge	<ol style="list-style-type: none"> 1. Open the Settings Menu. In the top righthand corner you'll see three dots in a horizontal line. ... 2. Locate Clearing Browsing Data. ... 3. Choosing What to Clear. ... 4. Restart the Browser.
Internet Explorer (Not Recommended)	<ol style="list-style-type: none"> 1. Select Tools > Internet Options. 2. Click on the General tab and then the Delete... button. 3. Make sure to uncheck Preserve Favorites website data and check both Temporary Internet Files and Cookies then click Delete.
Safari (Apple iPhone)	<ol style="list-style-type: none"> 1. Launch the Settings app from the Home screen of your iPhone or iPad. 2. Scroll down and tap on Safari. 3. Now scroll all the way to the bottom and tap on Advanced 4. Tap on Website Data. ... 5. Scroll to the bottom again and tap on Remove All Website Data. 6. Confirm one more time you'd like to delete all data.
Chrome (Android Phone)	<ol style="list-style-type: none"> 1. Open the Chrome browser and tap the Menu button (☰) ... 2. Tap "Settings" in the menu that appears. 3. Tap "Privacy" in the Advanced section. ... 4. Scroll down and tap "Clear Browsing Data." ... 5. Ensure that "Cache" and "Cookies, site data" are checked and then tap "Clear."

Before Beginning Any Service or Repair:

Use a hand-held propane leak detector (“sniffer”) to ensure no propane is present in the immediate area, the inside of the display case and the inside of the refrigeration system. R-290 is an odorless refrigerant. Keep the area clear of all customers and non-essential or unauthorized personnel.

Verify that all repair parts are identical models to the ones they are replacing. Do not substitute parts such as motors, switches, relays, heaters, compressors, power supplies or solenoids. Failure to do so can result in an explosion, death, injury and property damage. Parts used on hydrocarbon cases must meet specific UL certification for non-incendive or non-sparking components. Use only Hussmann approved parts approved through the Hussmann Performance Parts Website. <https://parts.hussmann.com/>

Brazing must not begin before all propane has been cleared from the immediate area — the inside of the displays case and the inside of the refrigeration system.

⚠ WARNING

- » Only Hussmann or factory trained technicians should service or repair this R-290 (propane) equipment.
- » Failure to follow instructions can result in an explosion, death, injury and property damage.

If a leak is detected, follow store safety procedures. It is the store’s responsibility to have a written safety procedure in place. The safety procedure must comply with all applicable codes such as local fire department’s codes.

At minimum, the following actions are required:

- Immediately evacuate all persons from the store, and contact the local fire department to advise them that a propane leak has occurred.
- Call Hussmann and/or a qualified service agent and inform them that a propane sensor has detected the presence of propane.
- Do not let any persons back into the store until the qualified service technician has arrived and that technician advises that it is safe to return to the store.

- The propane gas used in the unit has no odor. The lack of smell does not indicate a lack of escaped gas.
- A hand-held propane leak detector (“sniffer”) should be used before any repair and/or maintenance is attempted. All repair parts must be identical models to the ones they are replacing.
- No open flames, cigarettes or other possible sources of ignition should be used inside the building where the units are located until the qualified service technician and/or local fire department determines that all propane has been cleared from the area and from the refrigeration systems.

REPLACING REFRIGERATION SYSTEM COMPONENTS

⚠ DANGER

- » Only Hussmann service technicians or technicians qualified to handle R-290 (propane) refrigerant should service or repair this R-290 (propane) equipment. Failure to follow instructions can result in an explosion, death, injury and property damage.

⚠ WARNING

- » Component parts shall be replaced with like components, and servicing shall be done by factory authorized service personnel only, so as to minimize the risk of possible ignition due to incorrect parts or improper service.

CHARGING

A calibrated scale with +/-2 gram accuracy must be used to charge the system. The charge amount is shown on the serial plate. Only R-290 grade refrigerant can be used. Standard propane does not meet the purity/moisture content of R-290, and therefore cannot be used to charge cases.

No gas charge adjustments are allowed. When connecting hoses between the refrigeration system, manifold gauges, and refrigerant cylinder, ensure that the connections are secure and there are no potential sources of ignition nearby. Ensure that contamination of different refrigerants does not occur when using charging equipment.

Use dedicated hoses to service R-290 (propane) refrigeration systems. Hoses or lines should be as short as possible to minimize the amount of refrigerant contained in them.

Ensure that the refrigeration system is properly grounded prior to charging the system with refrigerant, to avoid the potential for static build-up.

Extreme care must be taken not to overfill the refrigeration system. After charging, carefully disconnect the hoses, attempting to minimize the quantity of refrigerant released. Further leak check the service ports, hoses, refrigerant tanks. The service ports shall be checked for leaks using a hydrocarbon leak detector with a sensitivity of 3 grams/year (0.106 Oz/year) leak rate.

Thoroughly leak check the service ports. If no leak is present, use a pinch-off tool to close the ends of the service tubes before brazing them shut. If a Schrader valve is used on the compressor service tube, it must be removed and the previous steps followed in order to braze the service tube shut.



WATER - (For Condensers)

Water-cooled condensers are designed to operate with a water/propylene glycol solution, supplied at a temperature of 50°F to 115°F (10°C to 46°C). A minimum of 10 percent propylene glycol by weight is recommended. If water piping is run outdoors, 35 percent propylene glycol by weight will give burst protection, (not freeze protection), to approximately -40°F (-40°C). **Regardless of the amount of propylene glycol, it must be ensured that the water loop has adequate corrosion inhibitors.**

The inlet and outlet water connections are attached using a 3/4 inch. NPTF male hose adapter.

Trapped air must be removed at high points of the water piping. Automatic air vent valves or manual valves may be used and should be located at high points in the piping by installing contractor.

The water flow requirements vary by case model and length. Refer to the technical data sheet for more information on specific case settings.

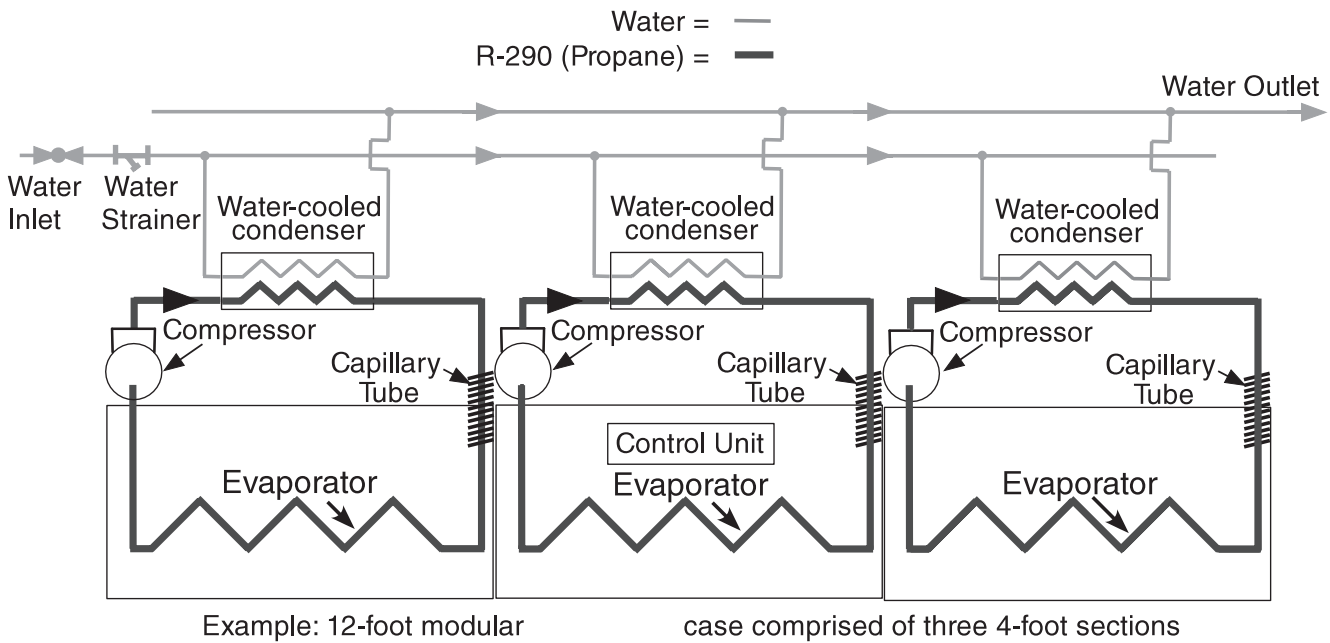

INHIBITED PROPYLENE GLYCOL SYSTEM REQUIREMENTS

Hussmann's laboratories have tested the concept, function, and reliability of inhibited propylene glycols for use as a secondary fluid for refrigerated systems in accordance with ASHRAE guidelines, UL and NSF standards.

The installation of a secondary fluid system must comply with the Safety Standard for Refrigeration Systems (ANSI/ASHRAE Standard 15), Refrigeration Piping Standard (ASME B31.5) and State and municipal building codes. Failure to follow requirements outlined in this document may result in corrosion of components.

Do NOT use Ethylene Glycol. Use of any secondary fluid other than inhibited propylene glycol is prohibited and voids the Hussmann limited warranty.

PIPING REQUIREMENTS

All field-installed materials that meet pressure and temperature ratings, material compatibility requirements and state and local building codes may be used.

Plastic

Any plastic piping used must be reliably proven, before installation, to meet all pressure, temperature and material compatibility requirements.

PLASTIC PIPING MUST BE RATED FOR HIGH TEMPERATURE (**HOT WATER**) APPLICATIONS. IF THE WATER STRAINER BECOMES CLOGGED, THE WATER COMING OUT OF THE UNIT COULD GET TOO HOT, CAUSING ORDINARY PVC PIPING TO MELT.

CAUTION

- » Plastic must be rated for hot water use! If a water strainer becomes clogged, the water outlet can be very hot, and this may cause plastic rated for only cold water to break.

Before using unproven plastic piping, check with the manufacturer to determine the suitability of the material for use with inhibited propylene glycol.

Copper

Copper pipe of M, K, or L grades can be used. Warning: Only flux materials formulated from water-soluble compounds that do not contain zinc or zinc compounds may be used for soft soldering. Copper to copper joints may be soft soldered or brazed. Soft solder must be used where the component manufacturer's installation instructions recommend.

Steel

Schedule 40 carbon steel pipe or stainless steel pipe (or tubing) is acceptable. Piping, valves and fittings can be made of ordinary steel or ductile iron but not gray steel. Do not use galvanized steel.

System Fluids

Only distilled or deionized water is approved by Hussmann. **Never mix fluids from different manufacturers. Use premixed fluid that is mixed with fully inhibited propylene glycol, not concentrated.** However, a small amount of concentrate should be kept on hand to allow for adjustment to the solution during start-up. If the mixing is to be done on site, use only distilled or de-ionized water. A refractometer, calibrated for fluids at room temperature, is used to measure dilution. Inhibited propylene glycol used in the system must be approved for use by the FDA.

Hussmann recommends using **DOWFROST™ inhibited propylene glycol**. Pre-diluted solutions (35% inhibited propylene glycol) of DOW-FROST™ are available from Dow. The ingredients in DOWFROST™ have been approved by the FDA and are listed as chemically acceptable by USDA.

The Dow Chemical Company
Midland, MI 48674
1-800-447-4369
www.dow.com

Requirements on system fluid:
Pre-mixed 35% inhibited propylene glycol

Typical Fluid Properties
Solution Composition is 35% inhibited propylene glycol by weight

pH of Solution 8.0 – 10.0
Specific Gravity (at 60°F) 1.033
Viscosity (at 20°F) 14.2 cP
Boiling Point of Solution 217°F
Freezing Point of Solution 2°F
Refractive Index (at 72°F) 1.3733

System Balancing
Balancing may be required to provide adequate coolant flow to each circuit in order to maintain the required waterflow. Balancing is achieved through the setting of balance valves located throughout the system piping.

The installation contractor must consult and be familiar with the manufacturer's Material Safety Data Sheets (MSDS) before handling any secondary fluid. The MSDS contains proper disposal and safety methods.

PRE-INSTALLATION SYSTEM CLEANING

Dow recommends the new piping system be cleaned using a 1-2% solution of trisodium phosphate (TSP), or equivalent cleaner and distilled or deionized water to remove grease, mill scale, or other residues from construction.

Repeat this process if necessary until the drained solution is clear and free from visible debris. The system should then be drained and flushed again using distilled or deionized water.

Hussmann only recommends distilled or de-ionized water for system flushing with 2% TSP. Dry nitrogen can be used for the initial pressure test, (60 to 75 psi), hold for three hours.

NOTICE

- » Use only distilled or de-ionized water for flushing with 2 percent tri-sodium phosphate (TSP). Use a pre-mixed inhibited propylene/glycol solution. If the mixing is to be done on site, use only distilled or de-ionized water. Do not use tap water.

TOP MOUNTED WATER & ELECTRICAL CONNECTIONS

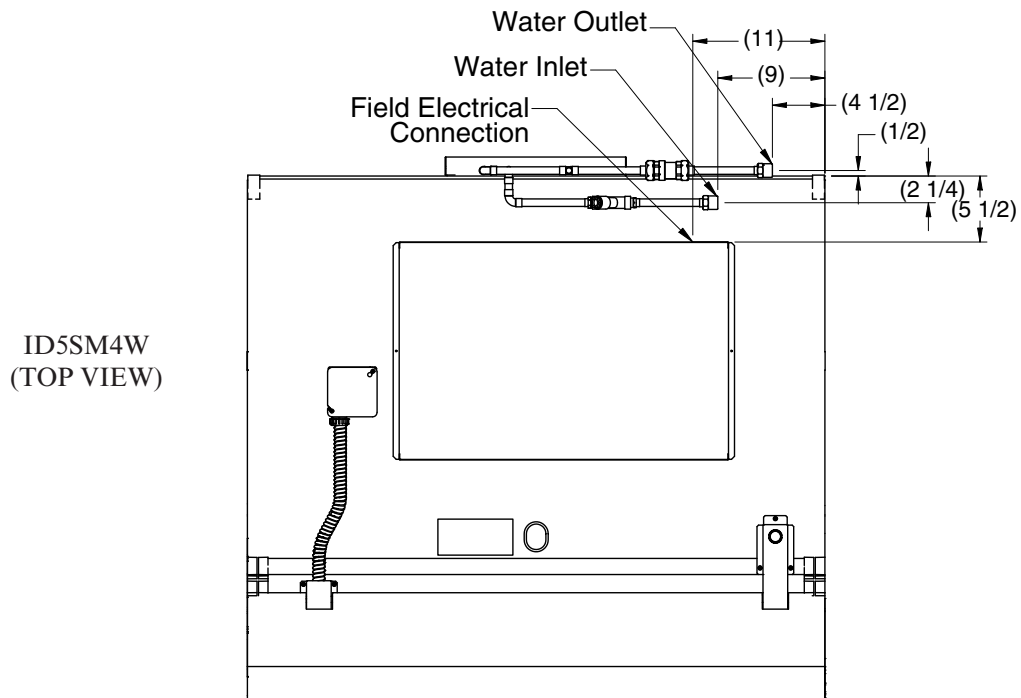
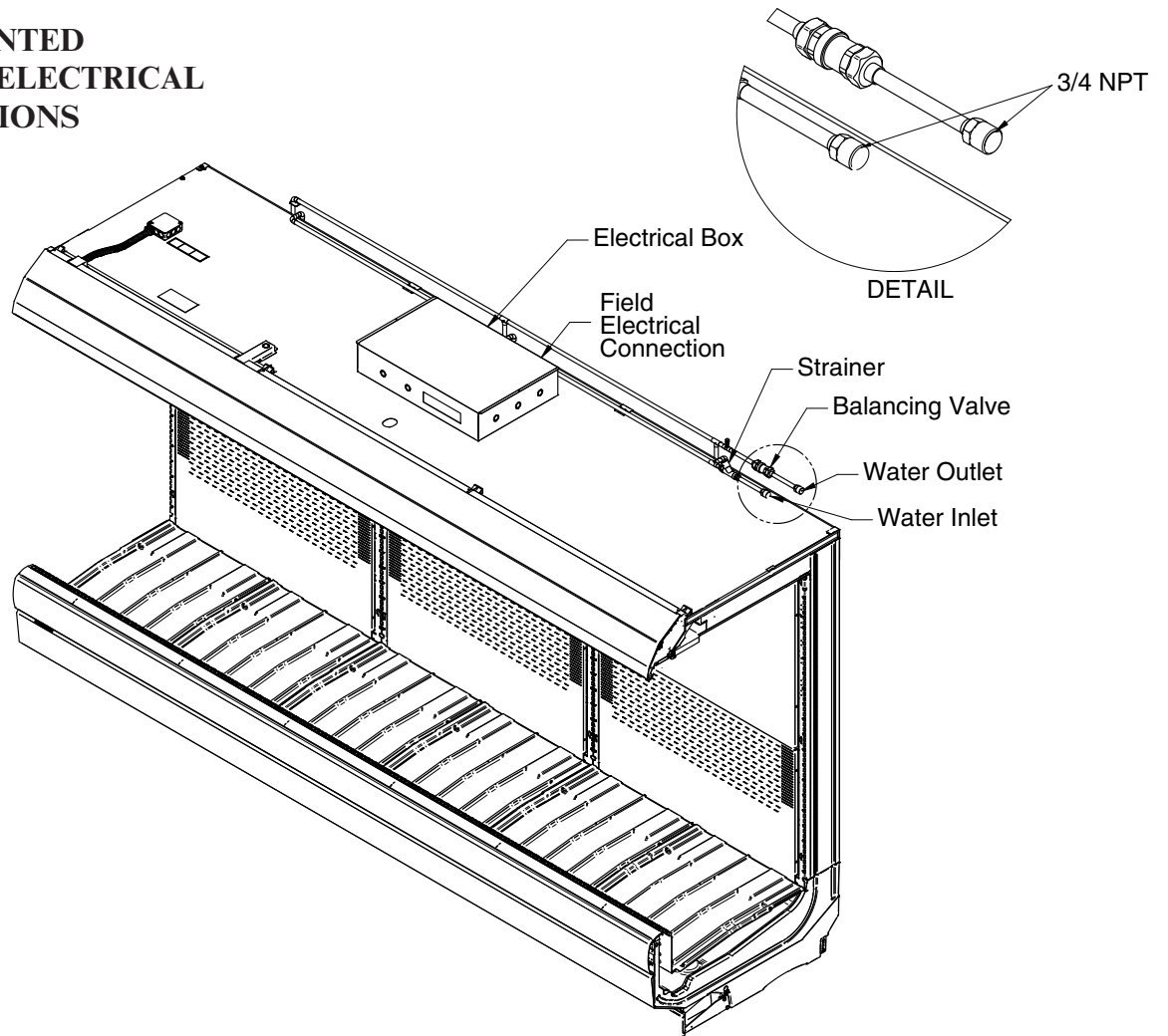

**TOP MOUNTED
WATER & ELECTRICAL
CONNECTIONS**

ID5SM6W
(TOP VIEW)

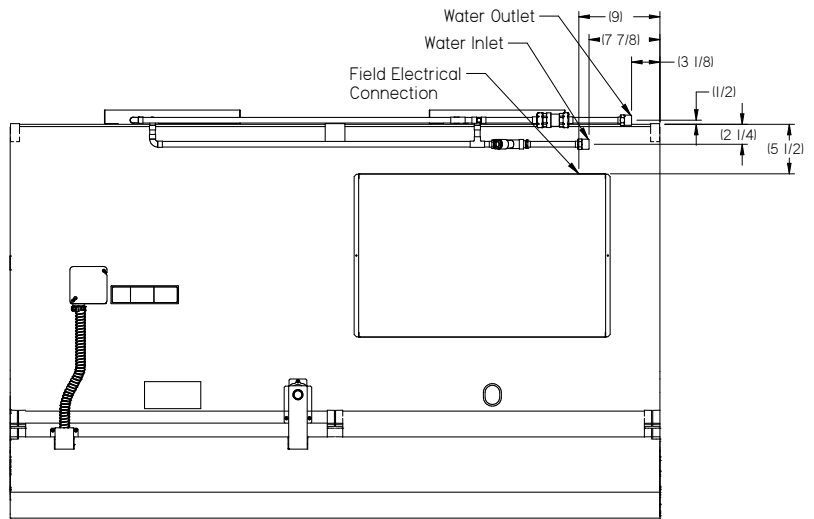

ID5SM8W
(TOP VIEW)

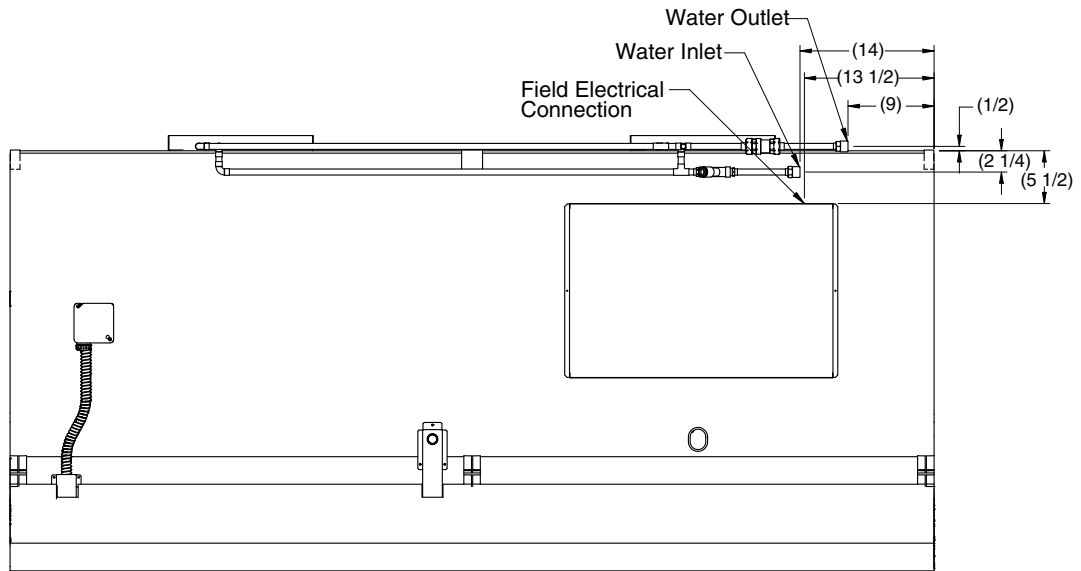

ID5SM12W
(TOP VIEW)

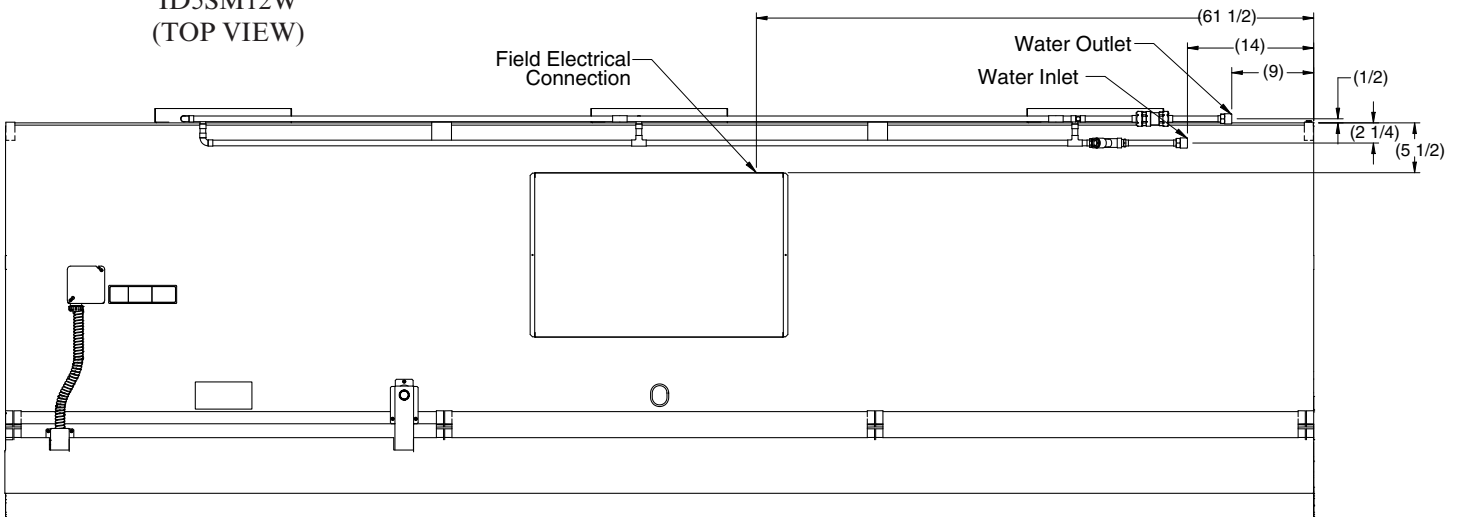



! DANGER

- » Risk of fire or explosion. R-290 (propane) refrigerant is flammable, and the refrigeration system should be serviced or repaired only by trained service personnel. Do NOT puncture refrigerant tubing.

REFRIGERATION

Each Insight self-contained case is equipped with its own condensing unit(s), one for every 4-foot module. The refrigeration system is sealed and factory charged. Thus, a 4-ft case has one condensing unit, an 8-ft case has two condensing units and a 12-ft case has three condensing units. Each case has one electronic controller.

Insight self contained merchandisers use R-290 (propane), refrigerant. All models have hermetic compressor(s). The systems employ capillary tubes for refrigerant flow control. If the capillary tube becomes plugged or damaged, replace the entire capillary tube. Refer to the case serial plate for refrigerant charge information.

CONDENSING UNIT ACCESS

Condensing units may be located on top of the case or behind the interior back panels depending on the case model. Remove the metal covers(s) to gain access to the condensing unit(s). All the cases and condensing units' electrical connections are done at the factory. The illustration shows the condensing unit and the metal enclosure. See location details on next Page.

! WARNING

- » Opening condensing unit electrical box exposes personnel to electrical hazard and should only be performed by a qualified service technician.

! WARNING

- » Attention trained service personnel: Mandatory safety service procedures must be followed when servicing the refrigeration system.

**REAR-MOUNTED
CONDENSING UNIT VIEWS**

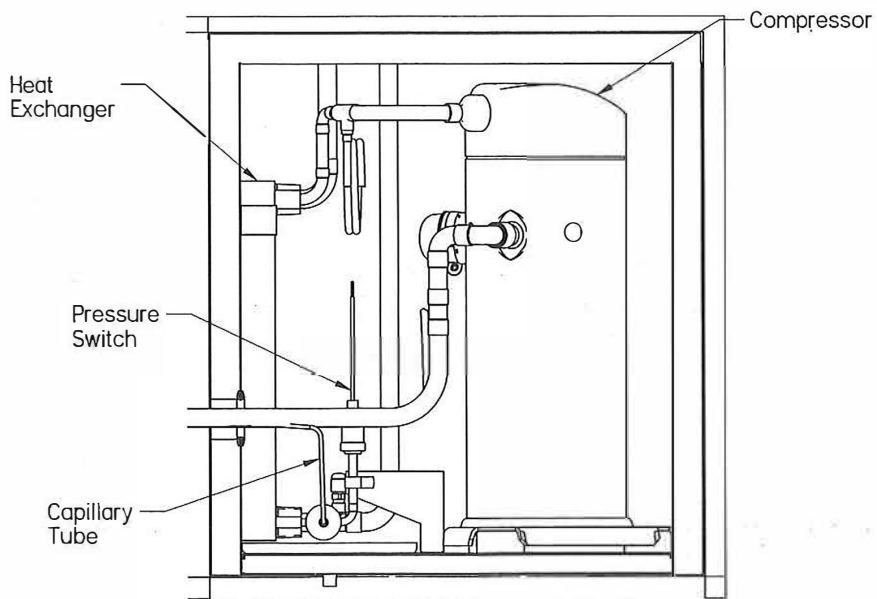
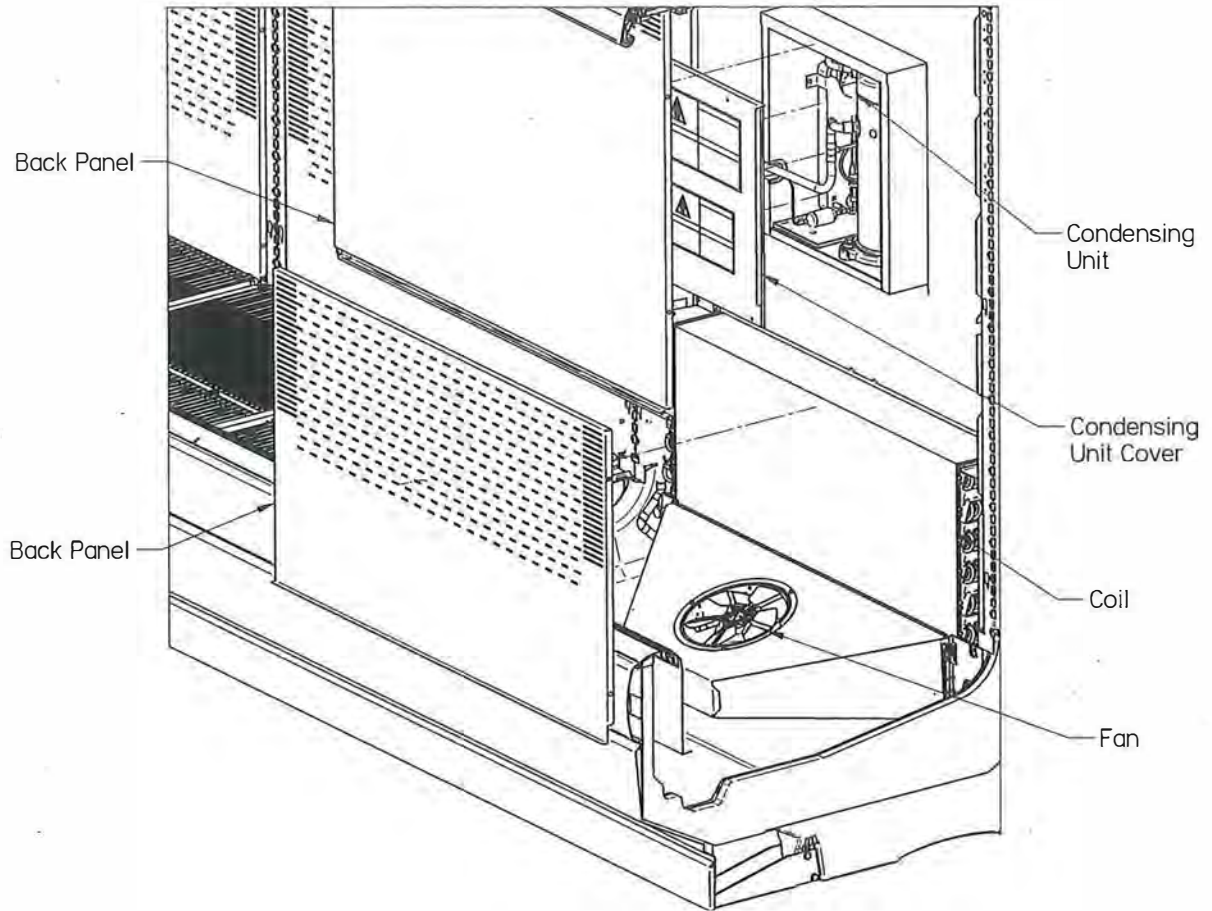

IDENTIFICATION OF WIRING

Leads for all electrical circuits are identified by colored plastic bands. These bands correspond to the *color code sticker* located inside the merchandiser's wireway cover. Color code is shown on next page.

ALWAYS CHECK THE SERIAL PLATE FOR COMPONENT AMPERES.

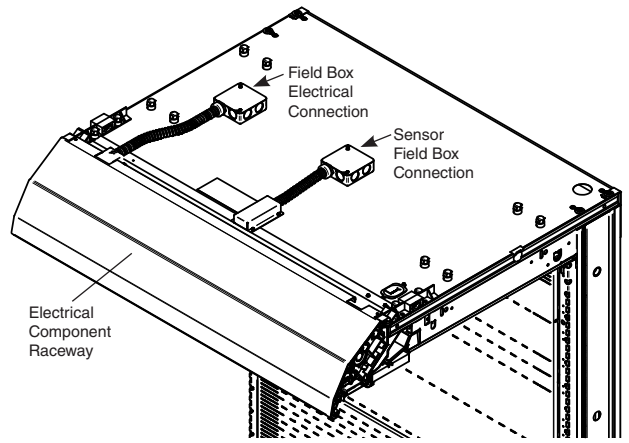

SENSOR LOCATION

Discharge air sensor is located in the case canopy by the honeycomb. An electrical box is shown at right for field installation of the sensor. (Field box may not be present if a sensor was not originally factory installed.)

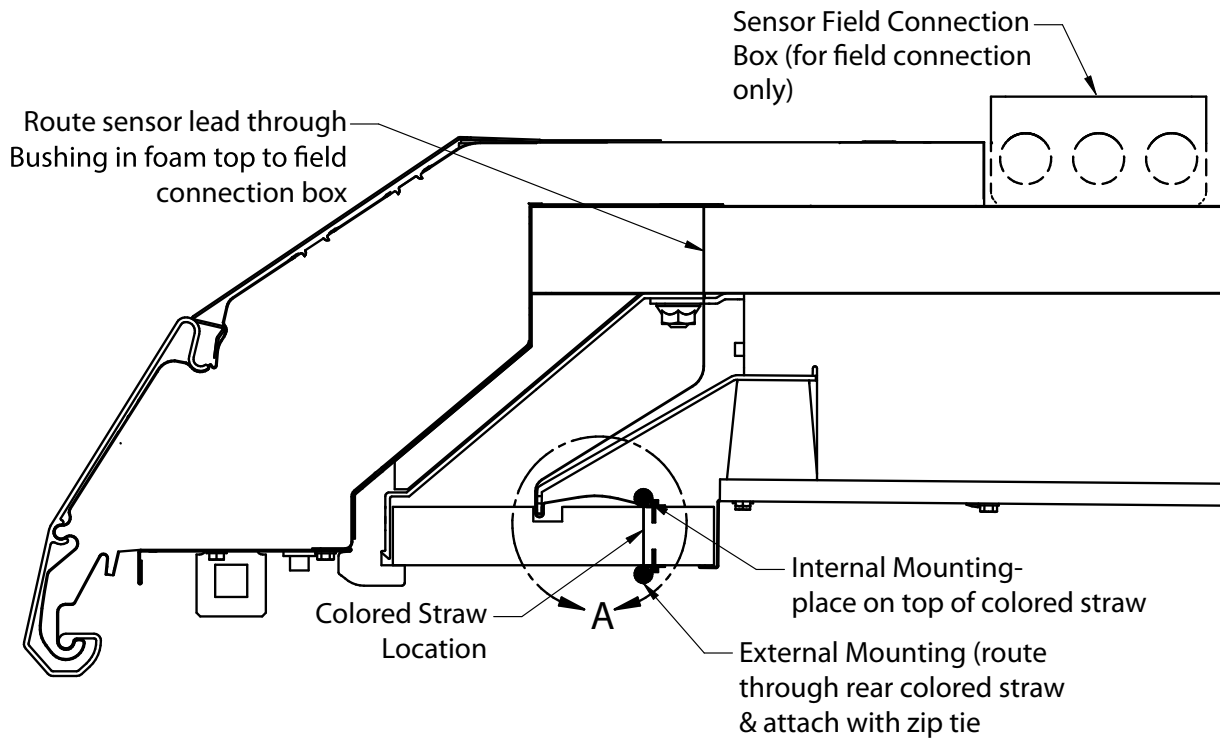
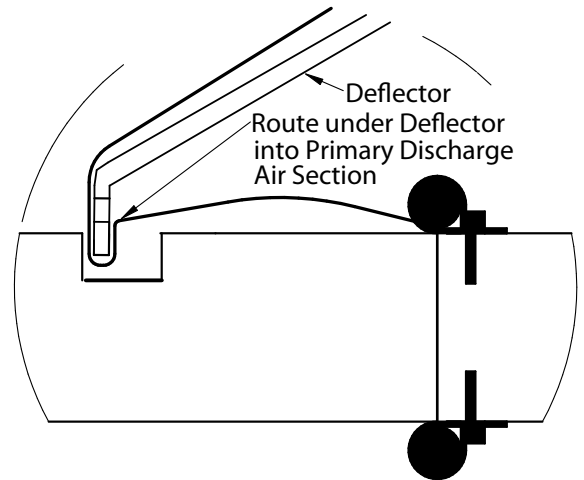

**ELECTRICAL ACCESS FOR
SIGN-READY & FLAT-FRONT
FASCIAS**

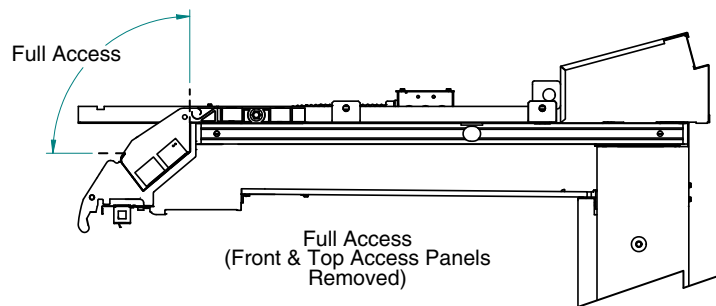
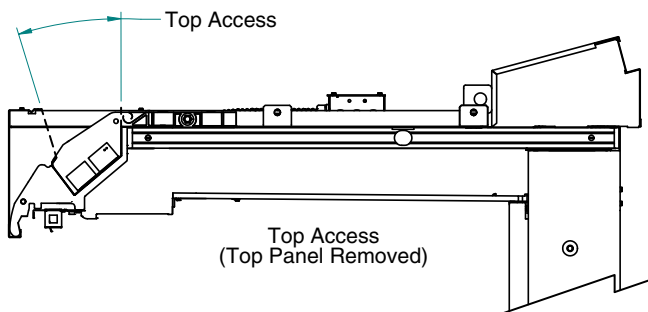
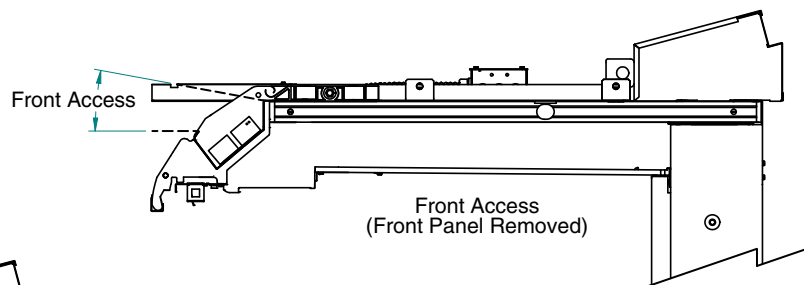
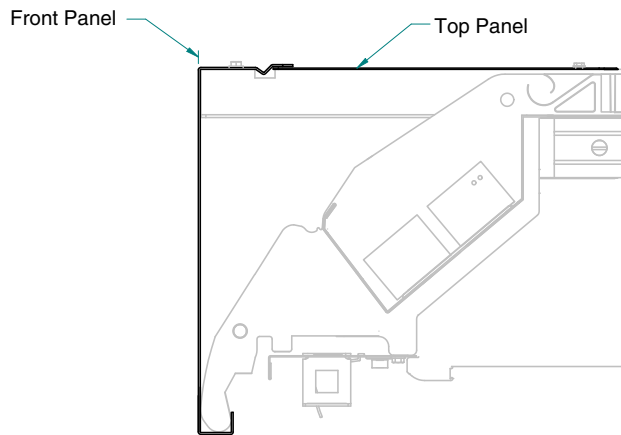

WIRING COLOR CODE

Leads for all electrical circuits are identified by a colored plastic band: neutral wire for each circuit has either White insulation or a White plastic sleeve in addition to the color band.

- | | |
|----------------------------------------------|----------------------------------------------|
| PINK..... REFRIG. THERMOSTAT LOW TEMP. | ORANGE OR |
| LIGHT BLUE ... REFRIG. THERMOSTAT NORM TEMP. | TANLIGHTS |
| DARK BLUE.... DEFROST TERM. THERMOSTAT | MAROON.....RECEPTACLES |
| PURPLE..... CONDENSATE HEATERS | YELLOWDEFROST HEATERS 120V |
| BROWN FAN MOTORS | REDDEFROST HEATERS 208V |
| GREEN* GROUND | *EITHER COLORED SLEEVE OR COLORED INSULATION |

**ELECTRICIAN NOTE: Use copper conductor wire only.
MERCHANTISER MUST BE GROUNDED**

THESE ARE MARKER COLORS, WIRES MAY VARY.

HANDLING ELECTROSTATIC SENSITIVE DEVICES (FAN SELECTOR)

Some Insight merchandisers are equipped with a fan speed selector to optimize fan speeds and enhance energy performance. The electronics may be standard or later installed to the cases as a kit. These electronics consist of an input in the motor, and a controller with a key that allows fan speeds to be changed. (Only a professional technician should make any changes to the fan speeds.) A different speed key may need to be ordered to change the fan speed. Contact your Hussmann representative to learn and order what speed key is appropriate for your products.

ESD (electrostatic discharge) sensitive device. Charged devices and circuit boards can discharge without detection. Although this product contains protection circuitry, damage may occur on devices subjected to high energy ESD. Proper precautions should be taken to avoid loss of functionality.

A field grounding kit is recommended for installation of components from a kit or for field service work performed by internal service personnel. The following equipment is recommended for work being performed in the case:



Example of Grounding Kit
3M 8507 with audible alarm

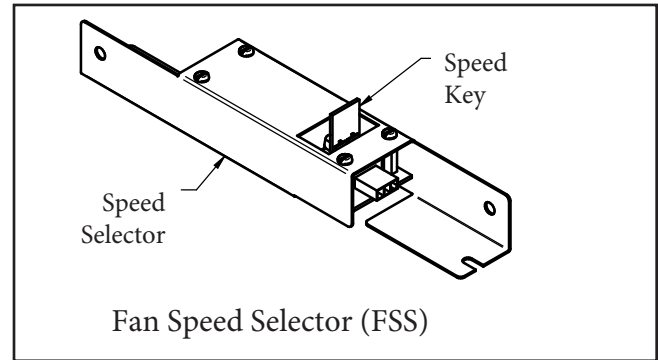

DO:

- Minimize handling.
- Keep parts in original packaging until ready for use.
- Store and carry components in Original Manufacture Packaging or equivalent Static shielding bags.
- Discharge static before handling device by touching nearby grounded surface.
- Handle devices by the body.
- Keep a dust free work area.

DON'T:

- Touch the leads of any device.
- Slide ES Sensitive devices over any surface.
- Store or carry components or assemblies in plastic bags.
- Store sensitive components in thermocole/ plastic foam.

Field Ground Kit with instructions for use
Recommended Suppliers/Distributors of
Equipment:

DESCO Industries

Part Numbers (18575 or 18576 or 95651)

3M Corporation

Part Numbers (8501 or 8505 or 8507 or FSK-L3RD)

Amazon, DigiKey, Grainger, Mouser, Newark.
Search under ESD Service Kits.

INSTALLING TYPE II FAN SPEED SELECTOR KIT

A fan speed selector may be required for a merchandiser to operate for certain applications such as Type II conditions. However, if the speed key is removed, the fans will return to the default fan speed, which typically aligns with Type I operation. Each key is configured from the factory to operate for the specific model for which it was ordered.

ANSI/NSF-7 Type II – Display Refrigerator / Freezer Intended for 80°F / 55% RH Ambient Application

Contact your Hussmann representative to order this kit if the cases in your lineup are required to operate in Type II conditions. The selector will operate up to 6 fan motors. Only an experienced electrician should install the fan selector.

1. Mount the selector inside of the wireway of each case. Insert the speed key into the selector. Insert harness connector (2-pin) into the Selector. The 2-pin side supplies power to the selector. It can be used with 110V or 220V circuits.

2. Insert the harness connector (3-pin) into the selector. The 3-pin side sends a signal to the fan motor and the fan speed RPM is now changed to the new setting.

Harness Routing and Field Connections are shown on the next Page.

⚠ WARNING

— LOCK OUT / TAG OUT —

- » To avoid serious injury or death from electrical shock, always disconnect the electrical power at the breaker when servicing or replacing any electrical component. This includes, but is not limited to, such items as doors, lights, fans, heaters, and thermostats.

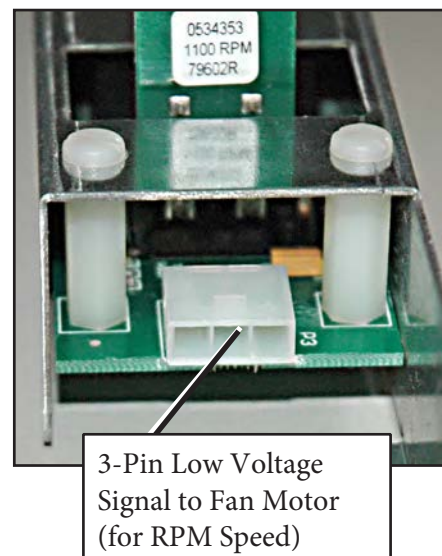
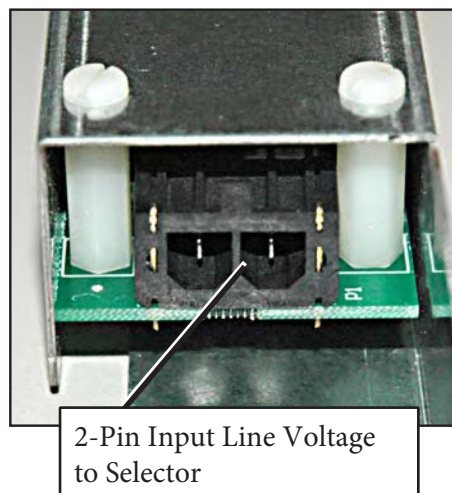

**TYPE II FAN SPEED SELECTOR
LOCATION**

**Fan Speed Selector Harness Routing
Tall Multi-Deck (when required)**

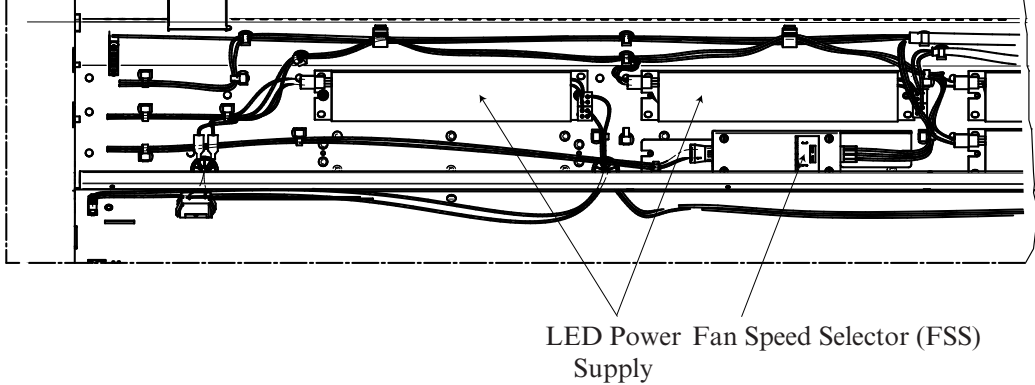

DRIP PIPING / FIT & FINISH / SPLASHGUARDS

WASTE OUTLET AND WATER SEAL

Insight merchandisers have one waste outlet located in the front center of the bottom or righthand side for 8 ft cases. Water seals are field installed with waste outlet to prevent air leakage and insect entrance into the case. Tees and clean-outs are supplied for each case. Cases with ultra-low fronts have a factory installed water seal.

A hat-shaped strainer is also shipped with the merchandiser. Place strainer over the waste outlet as shown below.

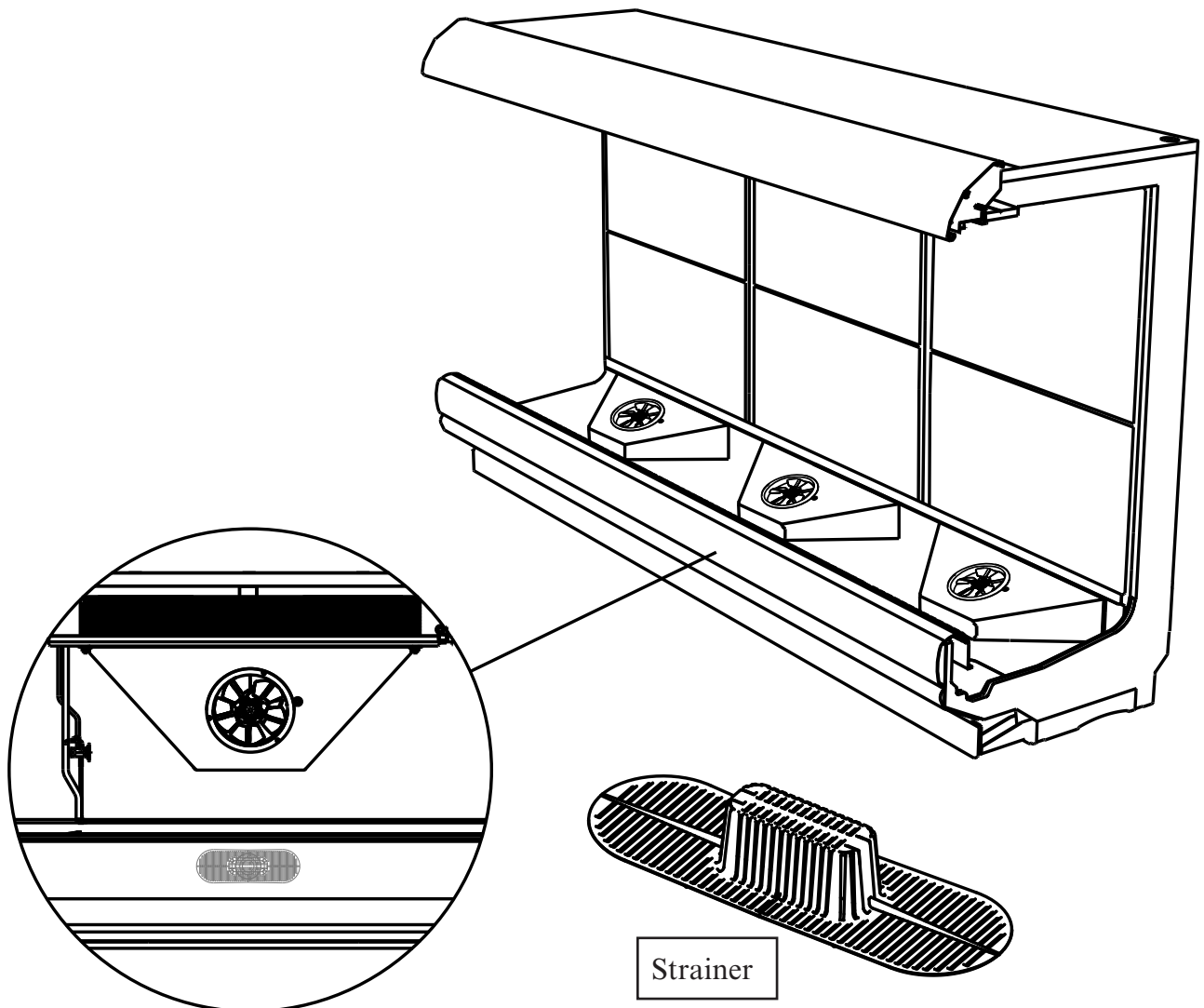
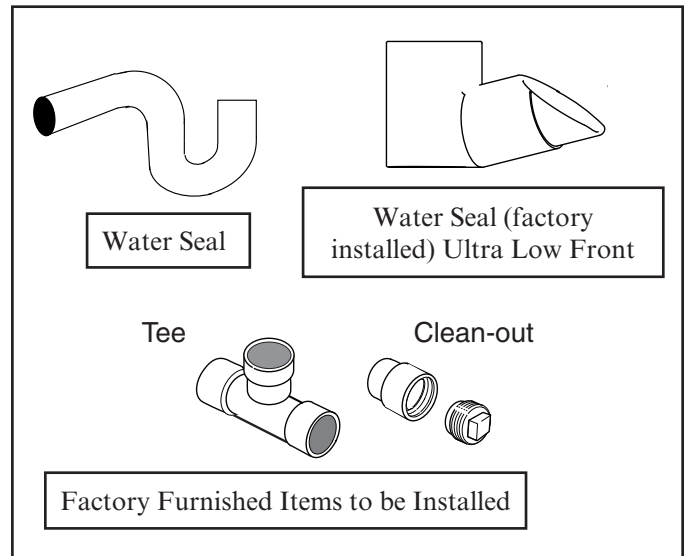

INSTALLING DRIP PIPING

Poorly or improperly installed drip pipes can seriously interfere with the merchandiser's operation and result in costly maintenance and product losses.

Optional drip pipe arrangements are shown on the next page. It is the installing contractor's responsibility to consult local agencies for local code requirements. Assemble the components using field-supplied PVC primer and glue according to the manufacturers direction.

Please follow the recommendations listed below when installing drip pipes to ensure proper installation.

1. When connecting drip piping, the "water seal" must be used as part of the drip piping to prevent air leakage or insect entrance. Never use two water seals in series in any one drip pipe. Double water seals in series will cause an air lock and prevent draining.

2. Pitch the drip piping in the direction of flow. **There should be a minimum pitch of ¼ in. per ft (20 mm per 1 m).**

3. Avoid long runs of drip piping. Long runs make it impossible to provide the pitch necessary for good drainage.

4. All connections must be watertight and sealed with the appropriate PVC or ABS cement.



Never use drip piping smaller than the nominal diameter of the pipe or water seal supplied with the merchandiser.



It is the installing contractor's responsibility to consult local agencies for local code requirements.

Drip Piping Example for Standard Case Height (Not for Ultra Low Front Cases)

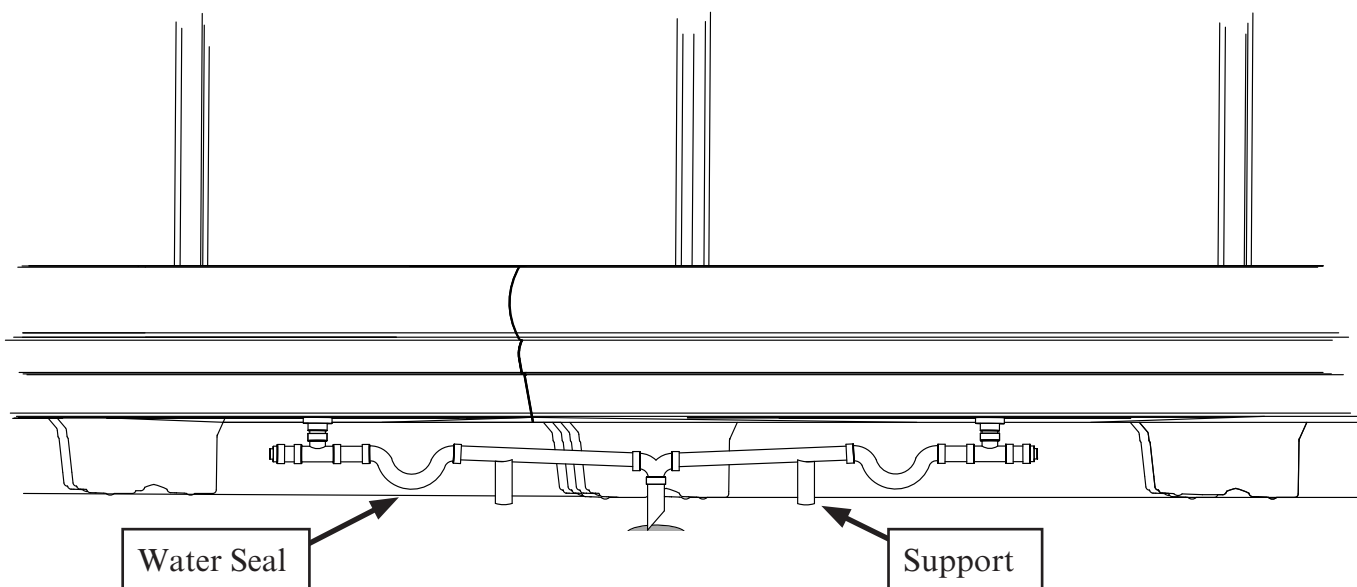

5. Ensure that drip piping is supported to relieve any stress on drip pipe connectors and drain hub. Drip piping **MUST** be supported no more than 24 inches from drain hub tee.

6. Provide a suitable air break between flood rim of the floor drain and outlet of drip pipe. To meet code on low base merchandisers, it may be necessary to install a field-supplied drip pipe reducer.



An alternative is to cut the last section of drip pipe at an angle.

7. Prevent drip pipes from freezing:

Do not install drip pipes in contact with uninsulated suction lines. Suction lines should be insulated with a nonabsorbent insulation material.

Where drip pipes are located in dead air spaces, such as between merchandisers or between a merchandiser and a store wall, provide means to prevent freezing.

Flush Floor Drip Piping Example for Ultra Low Front Cases



Water seal is to be oriented toward rear of case and is factory installed on case with ultra low fronts. Install tee to water seal.

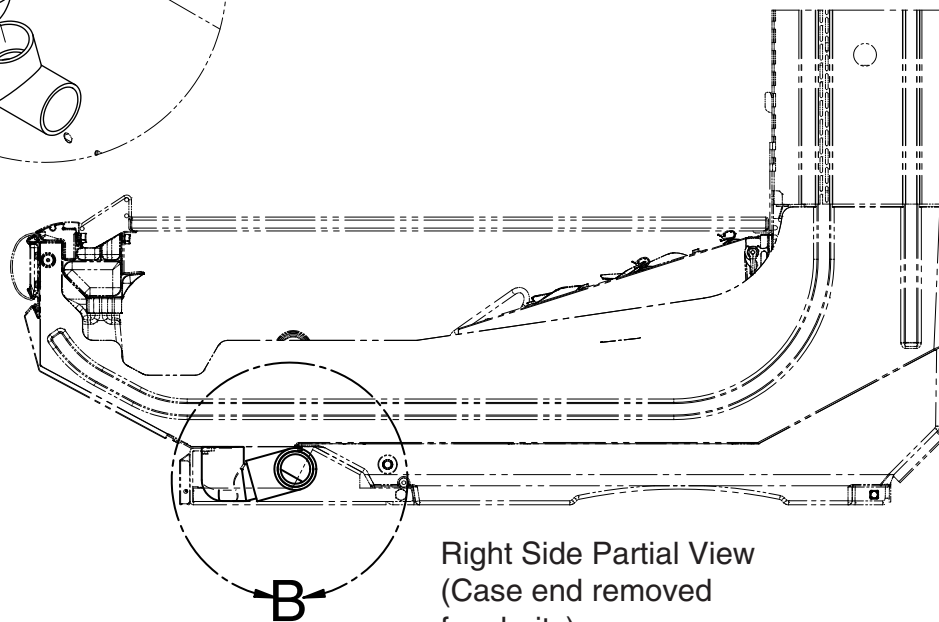
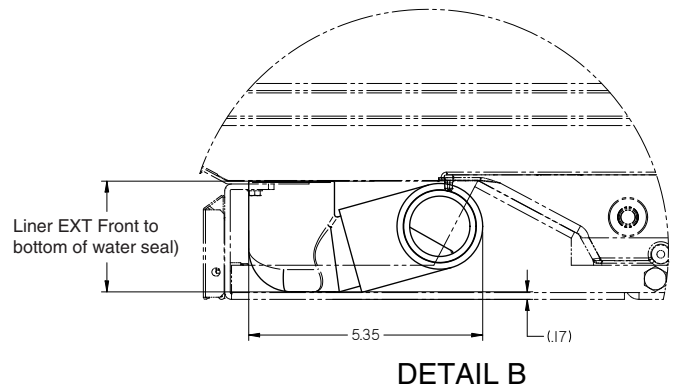
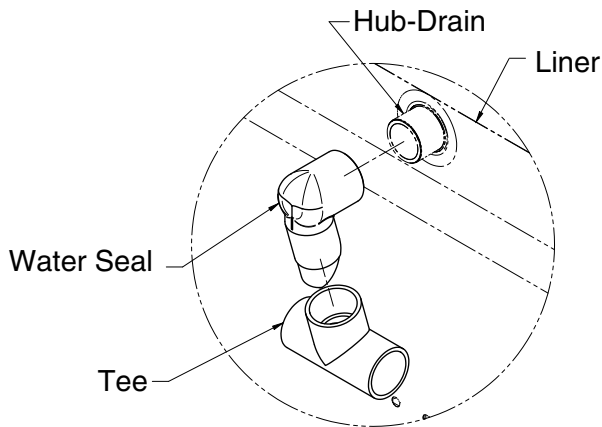

Right Side Partial View
(Case end removed for clarity)

Optional Hub Drain Drip Piping Example for Ultra Low Front Cases

There is limited space underneath the case for piping ultra low front cases. If there is a drain hub in the floor, use the ultra low front piping kit. This extends the splashguard forward. Follow the waste outlet location drawings on the following pages to install the drip piping in the correct location.

Item Number	Title	Quantity	Comments
1	ELBOW- AIR SEAL INSIGHT	1	FACTORY INSTALLED
2	TEE-1.25	1	FIELD INSTALLED
3	BUSHING-PVC REDUCER 1.250 X .50 SLIP	1	FIELD INSTALLED
4	REDUCER BUSHING-1.25x1.00	1	FIELD INSTALLED
5	PLUG-1.00	1	FIELD INSTALLED
6	PIPE-PVC .500 X 3.5 LONG	4	FIELD INSTALLED
7	ELBOW-PVC 90 DEG .500 SLIP	3	FIELD INSTALLED
8	ELBOW-PVC 22.5 DEG .500 SLIP	1	FIELD INSTALLED

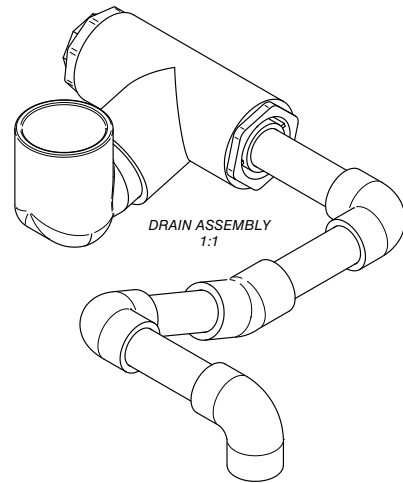
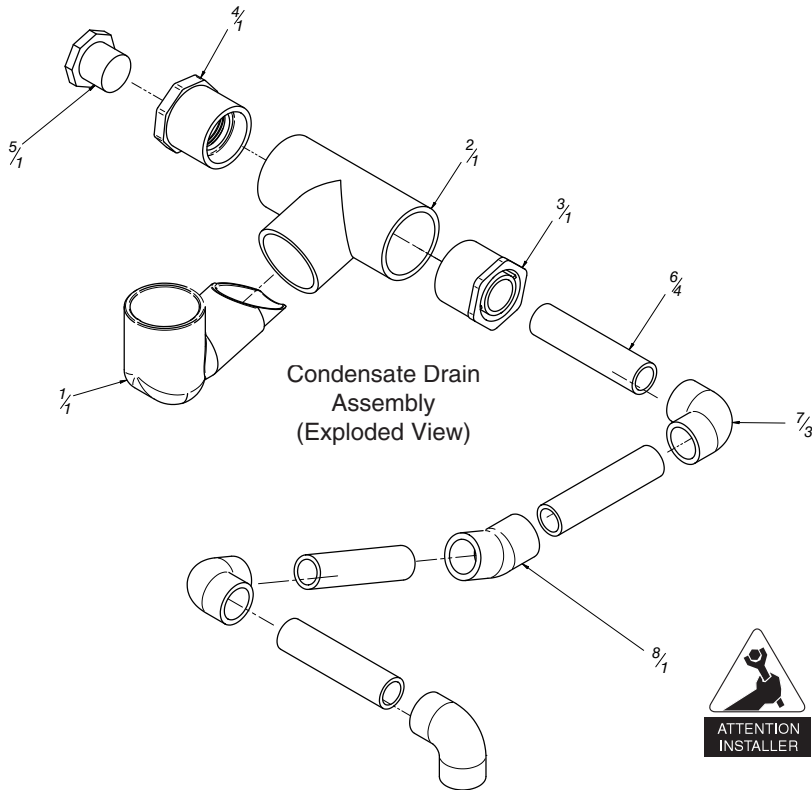

Water seal (factory installed) is to be oriented toward rear of case.

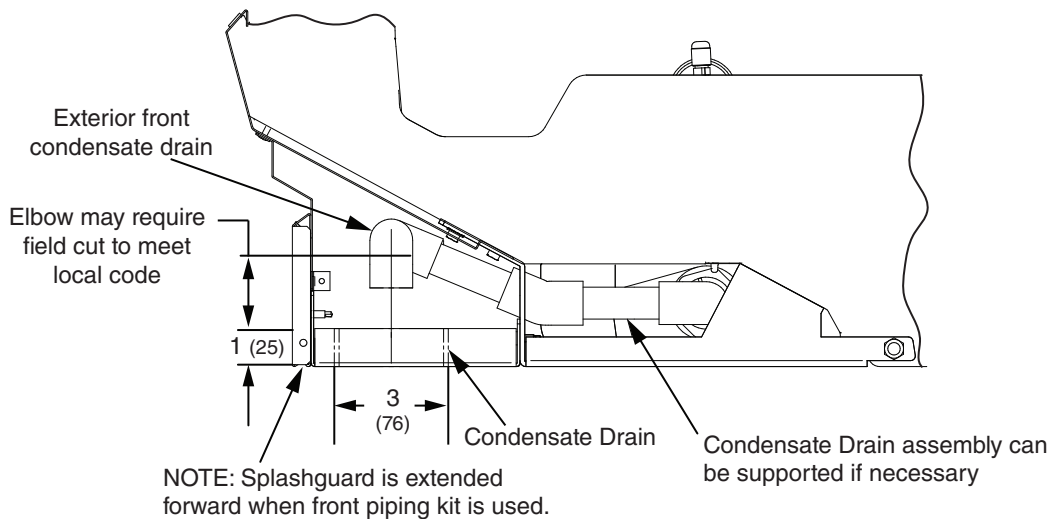

Drain Location with Drain Extension Kit (Dimensions in Inches)

Standard Depths Models Ending in SU	4-foot	6-foot	8-foot	12-foot
(A) RH end of case to center of original waste outlet	24 1/8	24 1/8	24 1/8	72 1/4
(B) RH end of case to center of relocated waste outlet (with drain extension kit)*	13 3/4	13 3/4	13 3/4	61 7/8
(C) Back of case to center of original waste outlet	33 1/2	33 1/2	33 1/2	33 1/2
(D) Back of case to center of relocated waste outlet (with drain extension kit)	38 1/4	38 1/4	38 1/4	38 1/4
(E) Back of case to the back of the relocated splashguard (with drain extension)	41	41	41	41

*Drain Extension shown piped to the right but may be piped either direction

Drain Location with Drain Extension Kit (Dimensions in Inches)

Narrow Depths Models Ending in NU	4-foot	6-foot	8-foot	12-foot
(A) RH end of case to center of original waste outlet	24 1/8	24 1/8	24 1/8	72 1/4
(B) RH end of case to center of relocated waste outlet (with drain extension kit)*	13 3/4	13 3/4	13 3/4	61 7/8
(C) Back of case to center of original waste outlet	28 5/8	28 5/8	28 5/8	28 5/8
(D) Back of case to center of relocated waste outlet (with drain extension kit)	33 1/2	33 1/2	33 1/2	33 1/2
(E) Back of case to the back of the relocated splashguard (with drain extension)	35 1/8	35 1/8	35 1/8	35 1/8

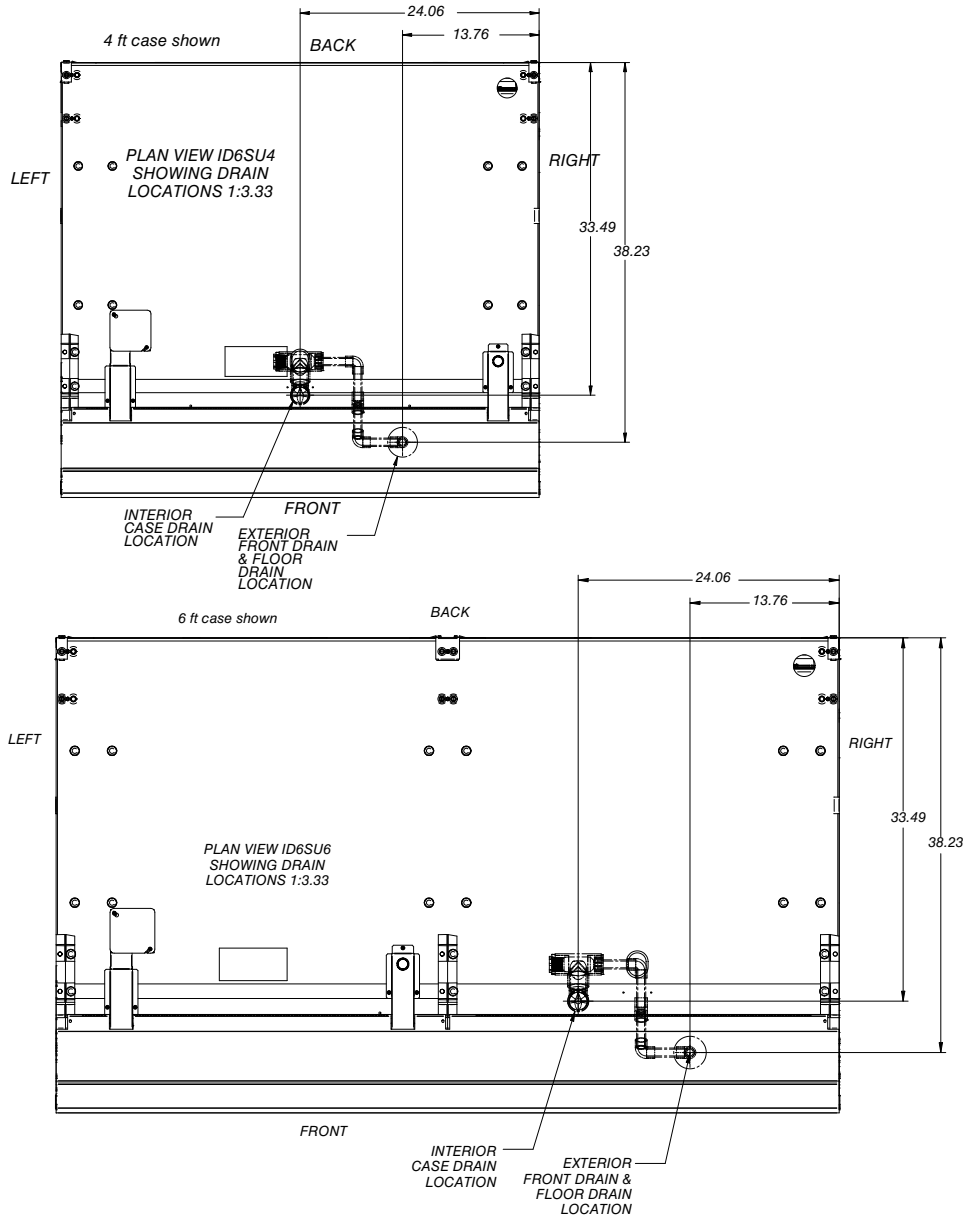

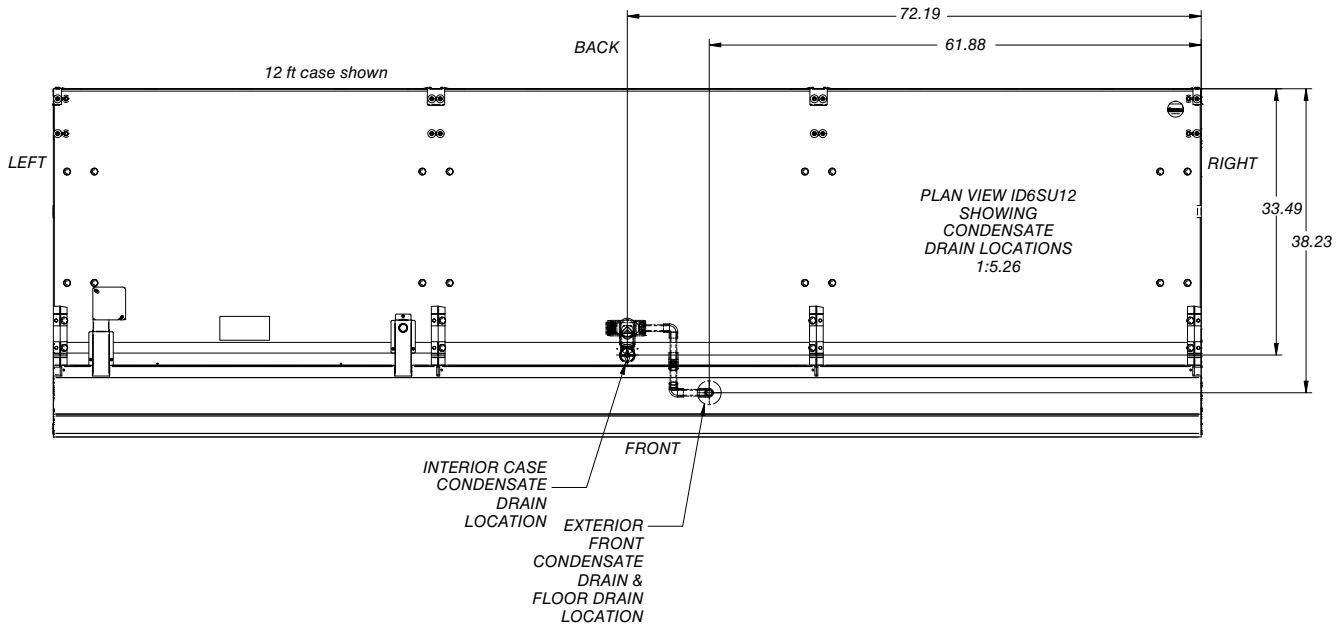
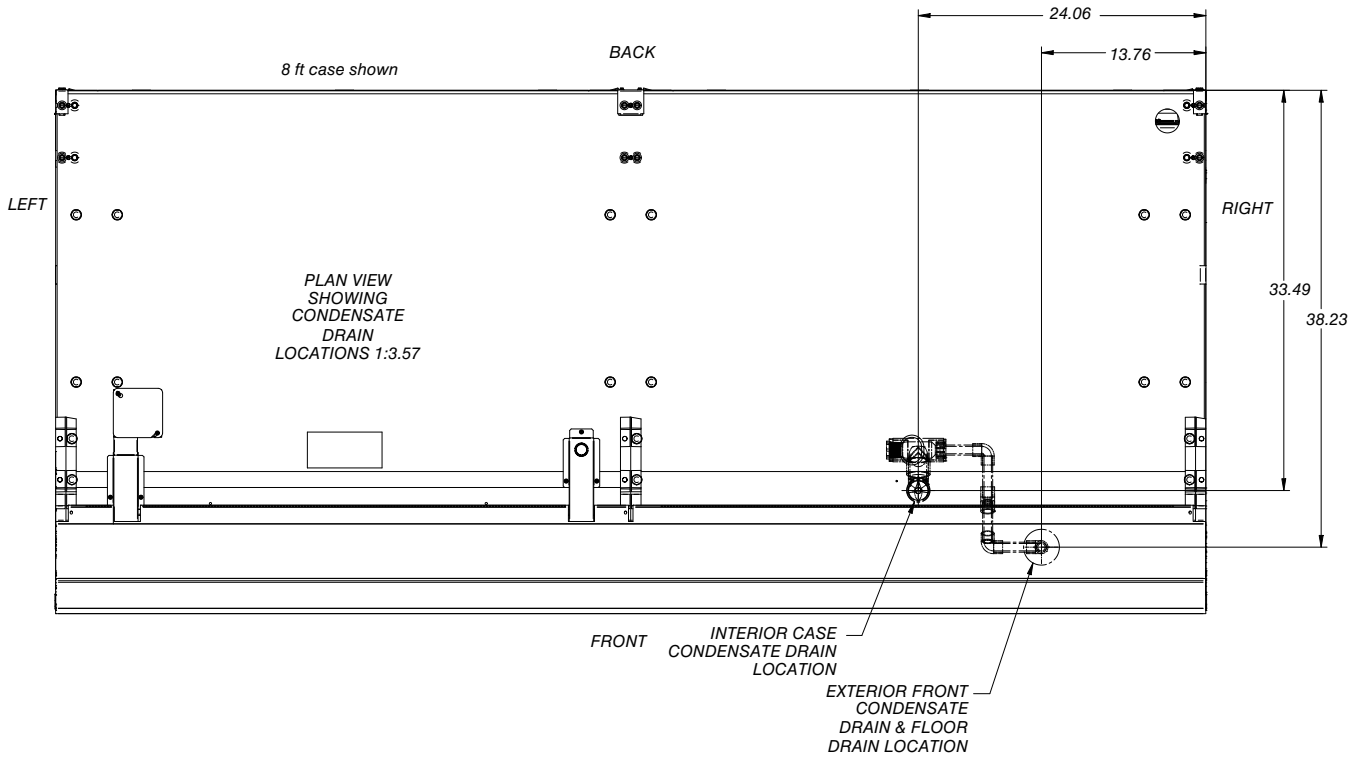

Final Alignment / Fit & Finish

Fascia Top Cap Alignment

Fascia Top Cap can slide toward the center of (multideck) case lineups to eliminate gaps.

1. Pull fascia top cap to uncover fixing screws.
2. Loosen the screws of fascia top cap.
3. Move fascia top cap towards the lineup center. Tighten the screws after finishing the alignment.
4. Snap fascia top cap to closed position.

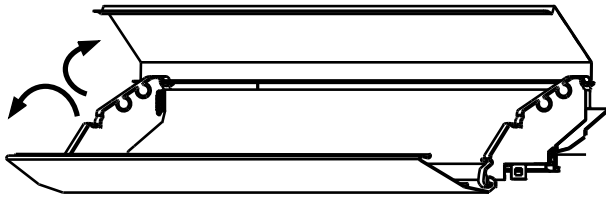

2. Loosen the screws of fascia top cap.

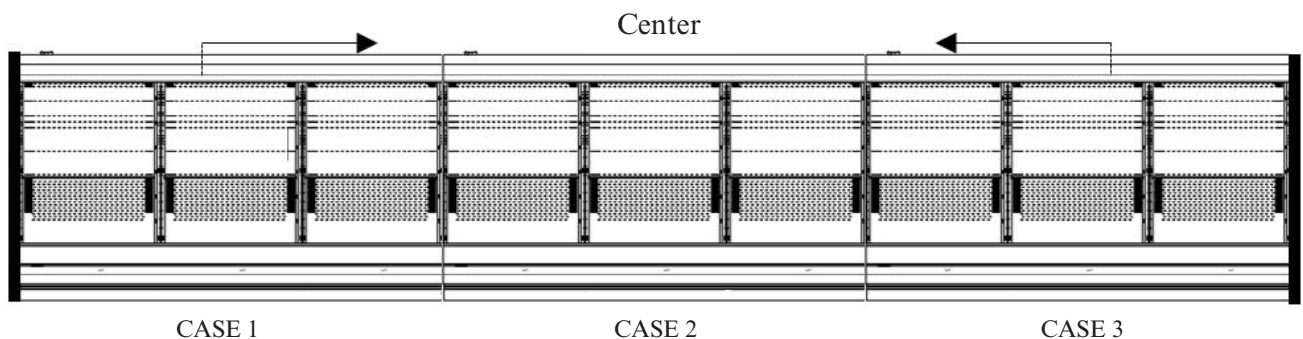
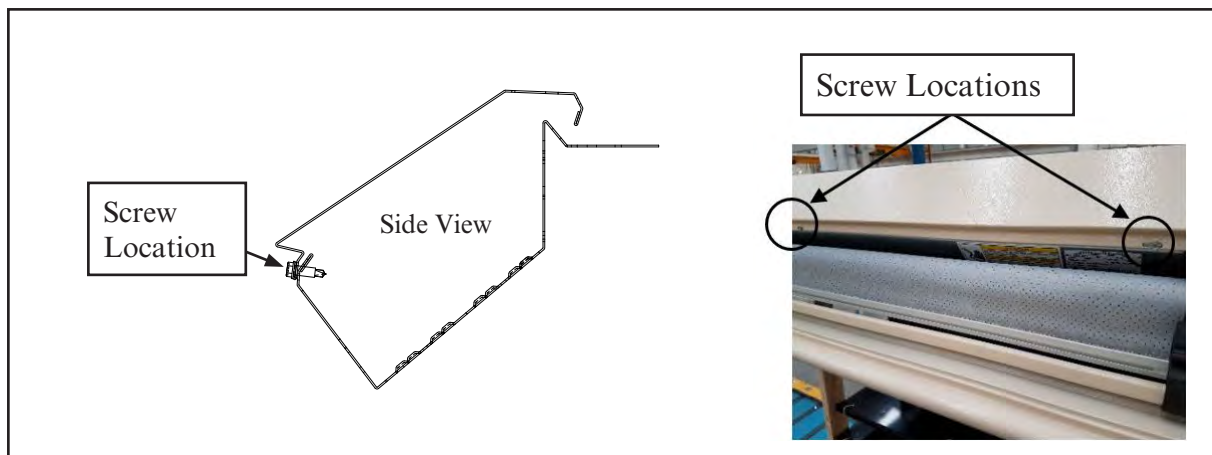

Fascia Panel Alignment

Fascia panel can slide toward the center of (multideck) case lineups to eliminate gaps.

Fascia trim is then needed at the end of either side of the lineups to eliminate gaps at the ends.

1. Slide fascia panels toward lineup center as shown in the illustration below.

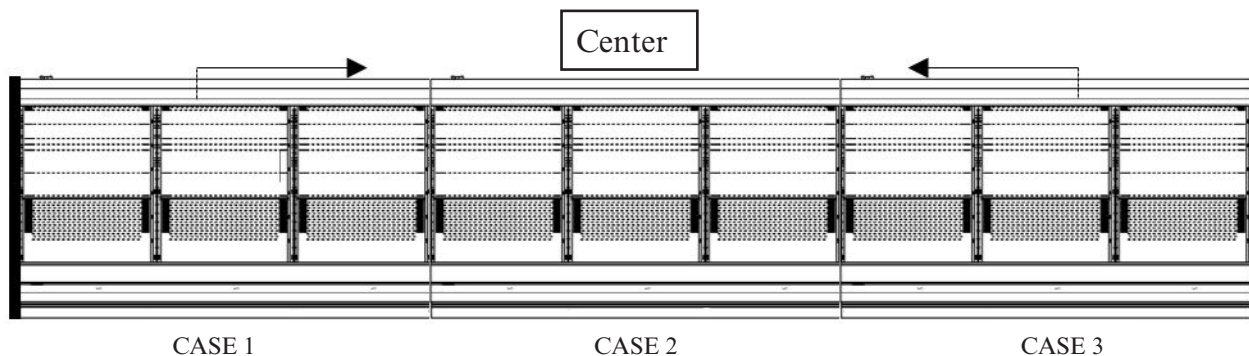
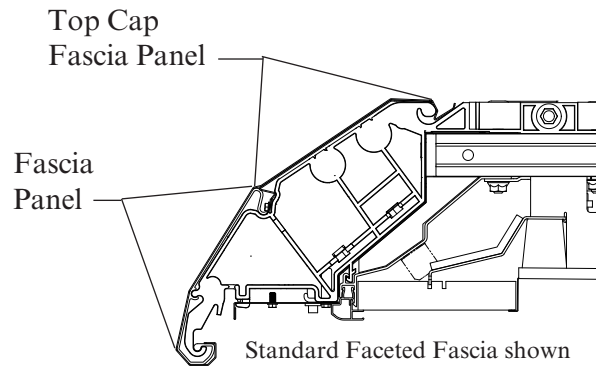

2. Place fascia trim along fascia surface adjacent to ends to eliminate gaps at the ends of the lineup.

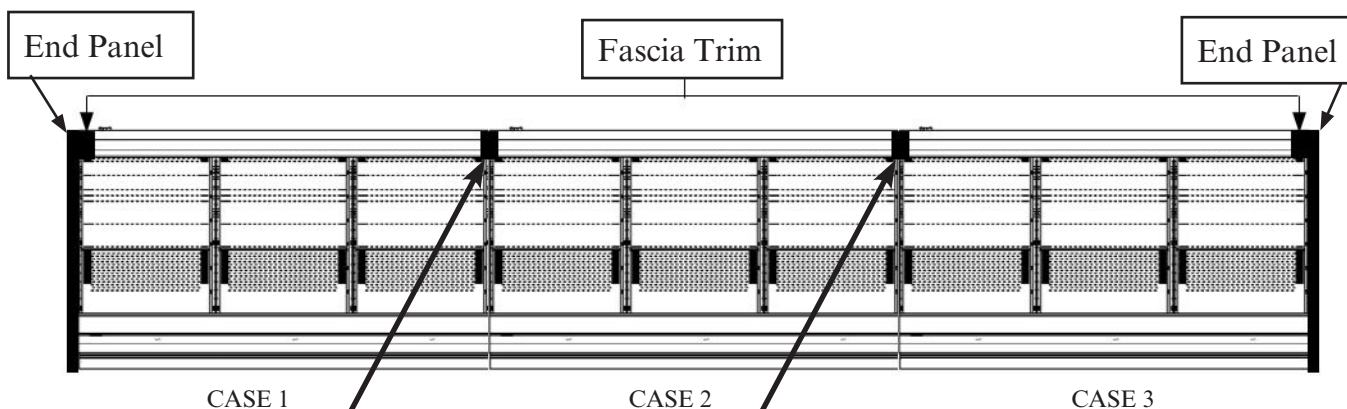

Optional Fascia Trim can be applied to case-to-case Fascia Joints

Front Panel Alignment

Front Panels can slide toward the center of (multideck) case lineups to eliminate gaps.

1. Loosen the front panel screws located at the bottom of Front Panel.
2. Slide front panel towards the lineup center to eliminate gaps between front panels. Tighten the screws after finishing the alignment.

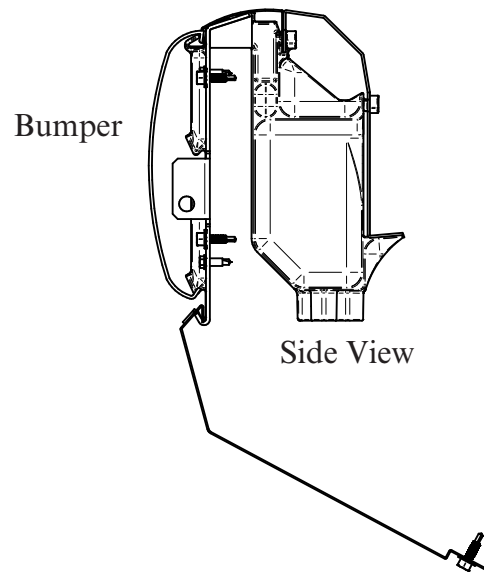

NOTE  Remove Front Skid Brace before aligning Front Panels. Align Panels before installing the Splashguard Front.

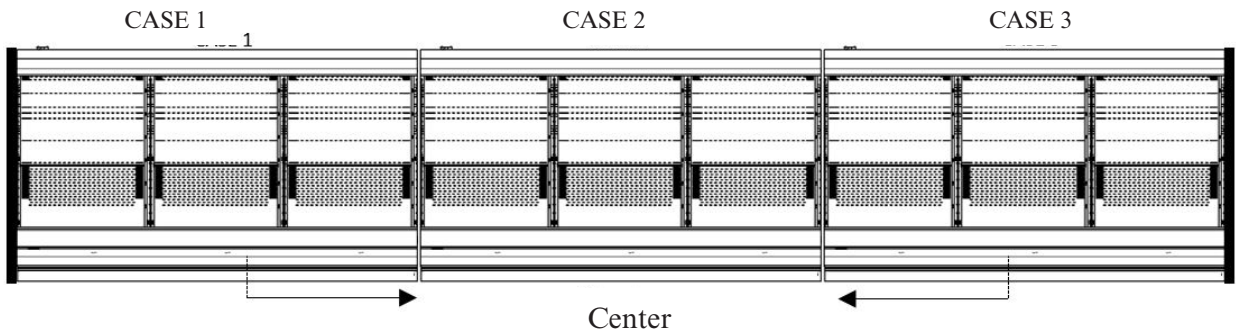

INSTALLING END SPLASHGUARDS

(Standard Case)

1. End splashguard must be slid in from the front, so that it fits behind the end panel. Attach end splashguard brackets to base at locations shown in the illustrations below.

2. Align forward edge of splashguard end panel to the inside of front splashguard. Fasten end splashguard to bracket with screws.

3. If end assembly bolt is loosened & seal broken when installing end splashguard, apply caulk to seal end assembly to inside of case.

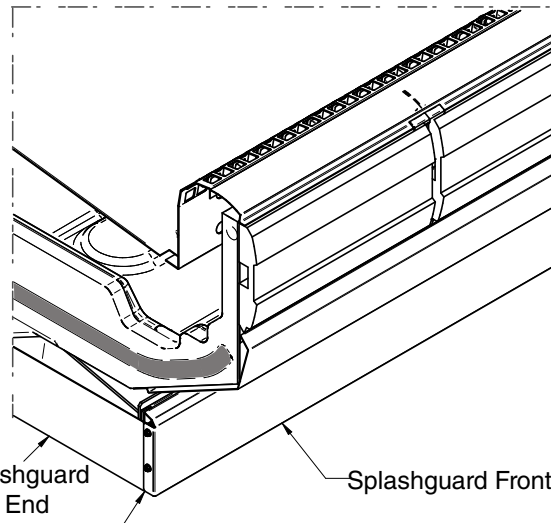

Place Splashguard - End to the inside of Splashguard - Front

NOTE End Splashguard Panel fits to the inside of End Assembly.

IMPORTANT Install end splashguard before installing front splashguards.

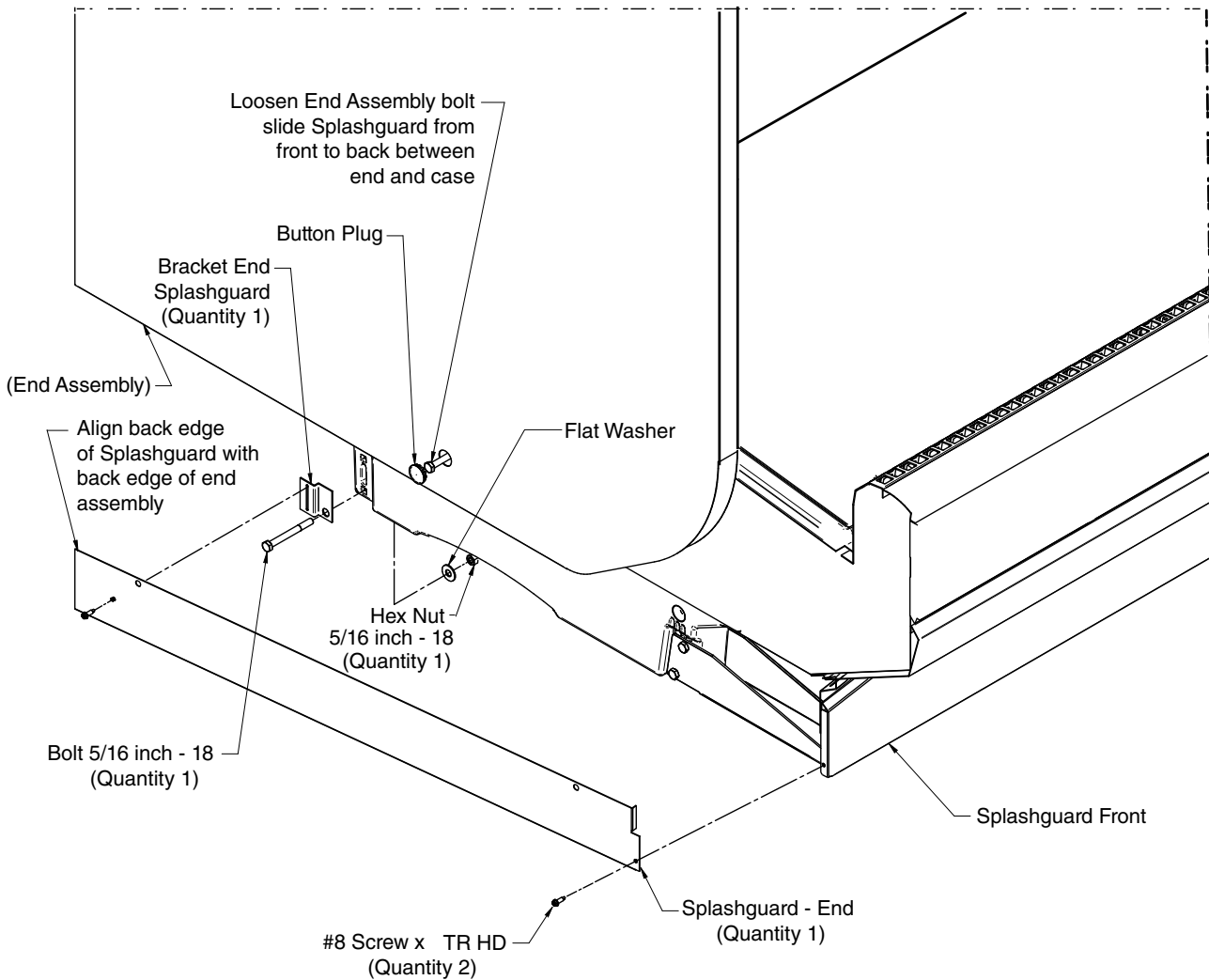

INSTALLING END SPASHGUARD

(Detail below for cases with elevated case heights.)

1. End splashguard must be slid in from the front, so that it fits behind the end panel. Attach end splashguard brackets (2) to base at locations shown in the illustrations below.
2. Align forward edge of splashguard end panel to the inside of front splashguard. Fasten end splashguard to bracket with screws.

NOTE End Splashguard Panel fits to the inside of End Assembly.

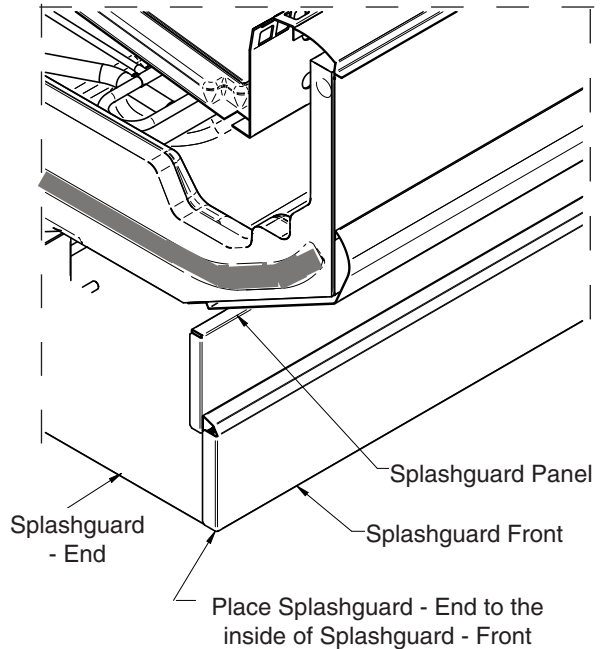

IMPORTANT Install end splashguard before installing front splashguards.

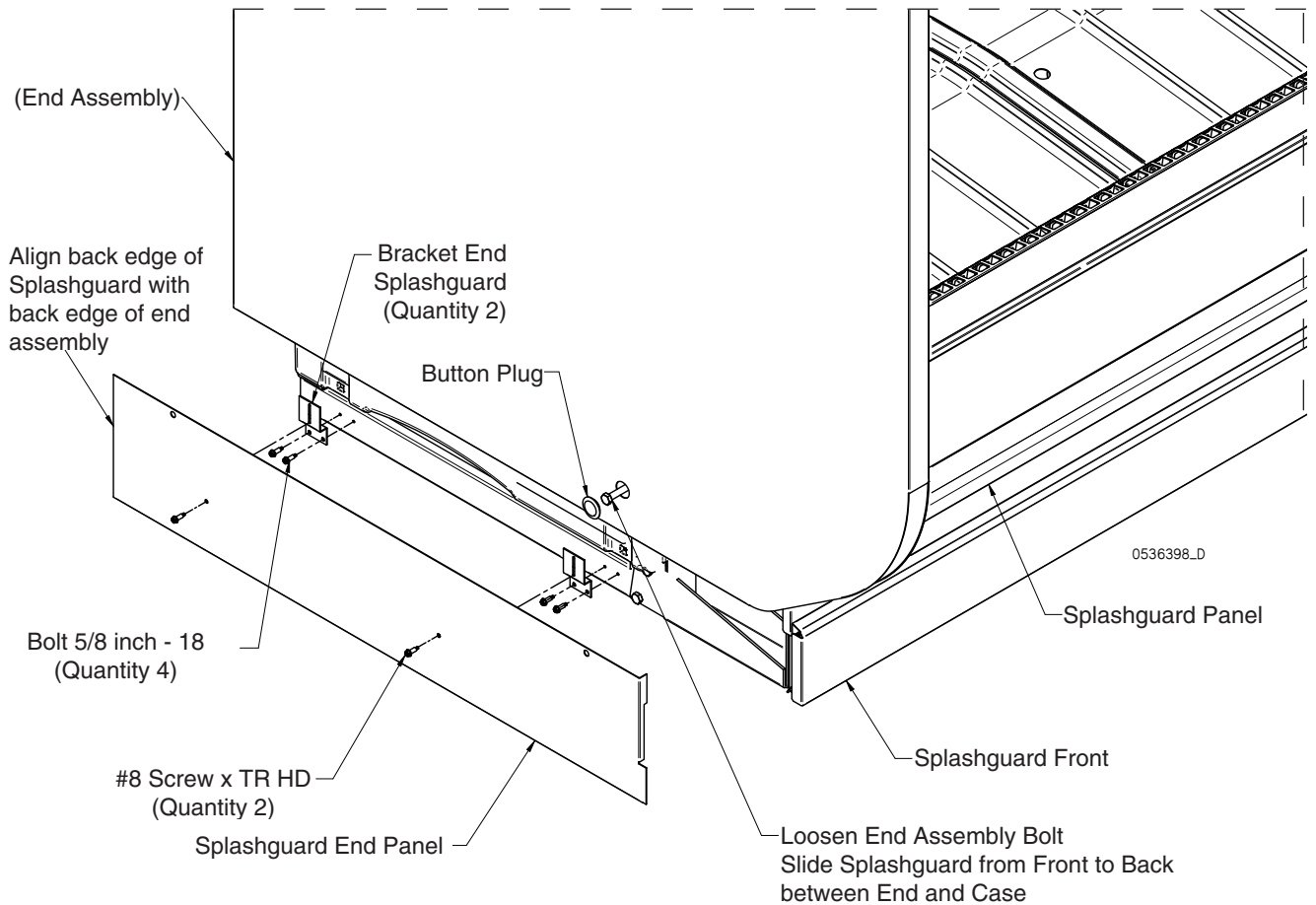

INSTALLING SPLASHGUARD BRACKETS

Position splashguard brackets at the front base (legs) of the merchandiser near the floor. Loosely assemble Splashguard Bracket using #8 x 5/8 inch SM screws as shown in Detail A below. More detail of splashguard installation shown on next page.



IMPORTANT Install Drip Piping Before Installing Splashguards

⚠ WARNING

» Use caution when working around refrigeration lines or water lines. Damage to equipment and personal injury could occur.

Splashguard Bracket and Panel Installation (12 ft Shown)

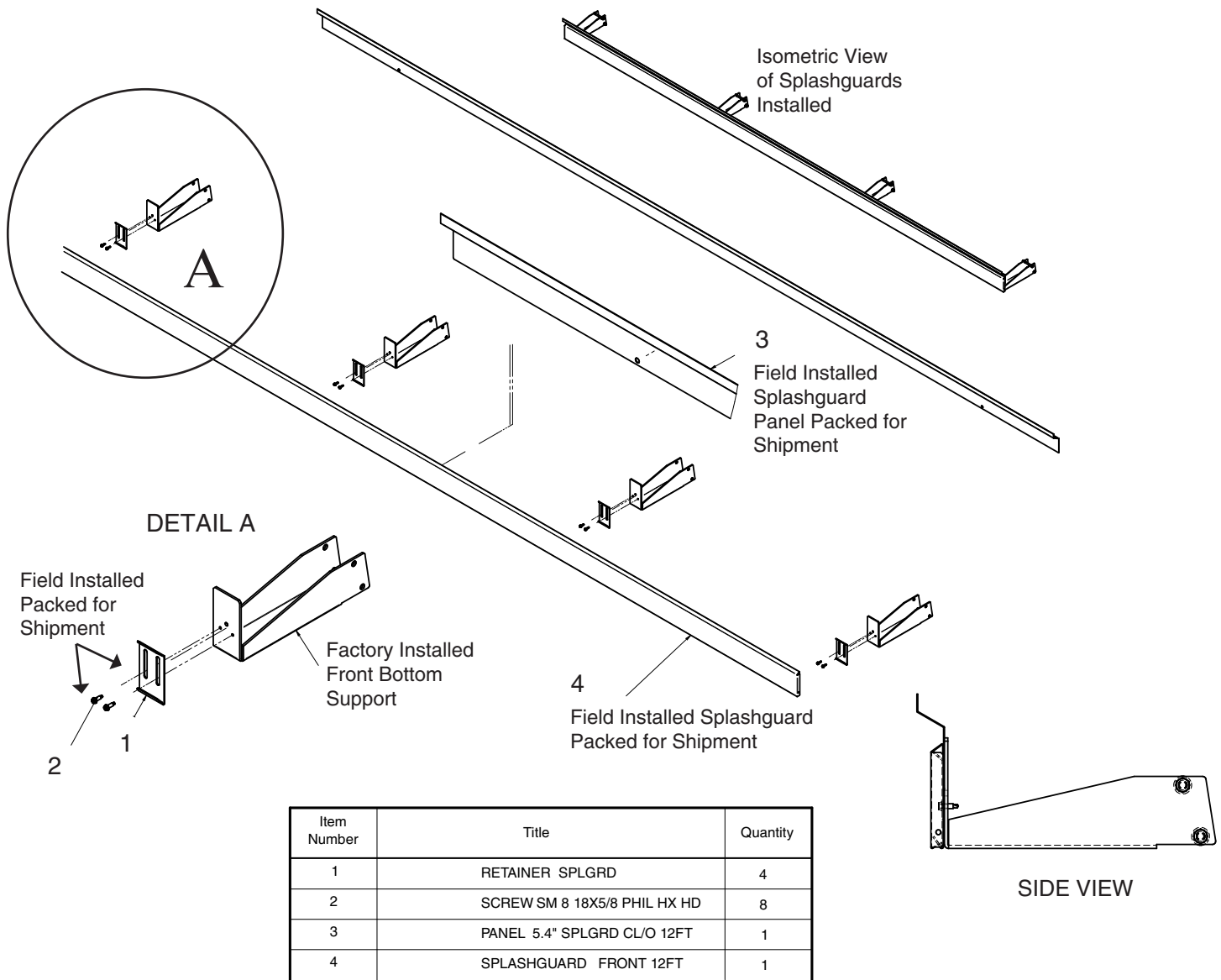

Item Number	Title	Quantity
1	RETAINER SPLGRD	4
2	SCREW SM 8 18X5/8 PHIL HX HD	8
3	PANEL 5.4" SPLGRD CL/O 12FT	1
4	SPLASHGUARD FRONT 12FT	1

INSTALLING SPLASHGUARDS (Retainers and Panels)

Splashguards are shipped inside each merchandiser, 4 brackets for 12 ft case, 3 for 6 ft, etc. **AFTER** merchandisers have been leveled and joined, and all drip piping, electrical and refrigeration work has been completed, install the splashguard.

To Install Splashguards:

1. Check to be sure that all splashguard brackets are level with the floor. Refer to previous page for additional exploded view pictures.
2. Loosely attach the lower splashguard retainer bracket using # 8 SM screws (1).
3. Install close-off panel as shown in (2 & 3). Slide splashguard close-off panel between the bracket and lower front support.
4. Raise the splashguard close-off panel to where the top fits into bend on the lower color panel, then tighten the splashguard brackets.
5. Fit the lower splashguard into the slots on the lower splashguard retainer. Lower splashguard snaps into place (4).

To install OPTIONAL cove trim to the splashguard:

1. Remove all dirt, wax and grease from the area of the splashguard where adhesion will be necessary to ensure a secure installation.
2. Apply a good contact cement to the cove trim and allow proper drying time according to the directions supplied with the cement.
3. Install the trim to the splashguard so that it is lying flush with the floor. **DO NOT SEAL THE TRIM TO THE FLOOR.**
4. **If required by local health codes** the Cove Trim may be sealed to the floor, using a silicone type sealer. Sealant must be removed and replaced when servicing.

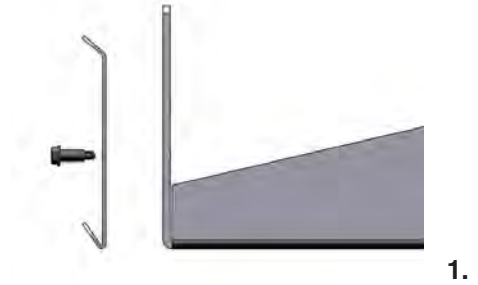

1.

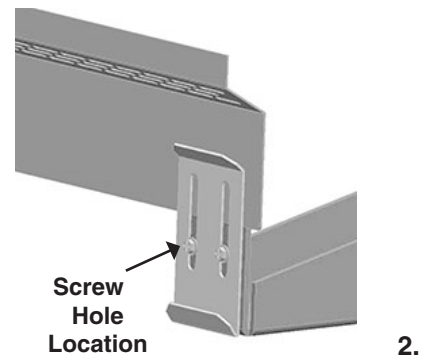

2.

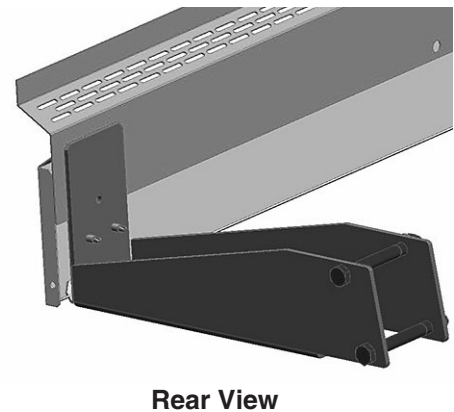

Rear View

3.

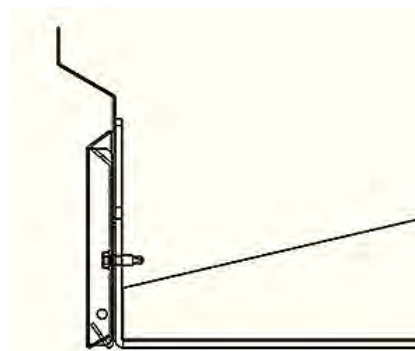

4.

**SPLASHGUARD ALIGNMENT
TO ELIMINATE GAPS IN CASE LINE-UP**

1. Slide Splashguard towards line-up center to eliminate Splashguards gaps.

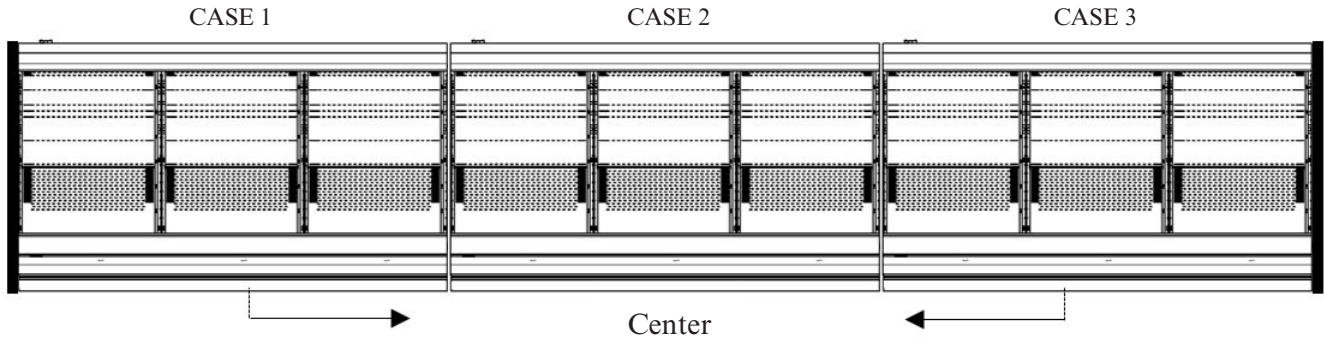

START UP / OPERATION

START UP

Prior to Start-up Check List

- Is the case connected to its proper nameplate power supply?
- Is there power on at the breaker panel?
- Are the water hand valves open?
- Is the chiller on and circulating water through the condenser(s)?
- Are there any leaks from condenser water connections? Clamps may need to be tightened.
- Do evaporator fans rotate freely? Are they plugged in?
- Is the water strainer clear of debris?

⚠ WARNING

- » Possible hazardous condition. Follow safety procedures outlined by store safety management.

⚠ DANGER

- » Due to risk of ignition resulting from incorrect parts or improper service, only Hussmann authorized personnel may service this equipment.
- » Component parts shall be replaced only with exact manufacturer and model number components. Failure to use authorized technicians could result in an explosion, death, injury and property damage.

Starting up the case

- Ensure the chilled water flow is on, and connect the case to power.

The case(s) will start automatically within 4 minutes. The controller will be activated and the case will begin to cool down.

NOTE: Compressor startups are staggered to prevent high electrical circuit demand.

Once the cases are running, listen for any unusual sounds or events. Examples include: evaporator fan blade interference. Compressors should run continuously at startup. Use an amperage meter to check the current to each compressor. Compressors are hermetic and very quiet.

4-2

CHECK: the water outlet temperature from each condenser. The outlet water temperature should be about 10°F (5.6°C) higher than the inlet water temperature.

CHECK: each fan to ensure it is running. The discharge air output at the top inside front of the case (honeycomb area) should be relatively even across the length of the case. **VERIFY** there are no leaks at the condenser water connections.

CHECK: the display on the discharge air sensor, which displays the case temperature. The display will indicate room temperature upon start up and decrease with run time.

ID6SU-W, IC5BU-W, ID5SL-W, and ID5SM-W Field Startup

When starting up the ID6SU-W, IC5BU-W, ID5SL-W, or ID5SM-W case for the first time: Verify that water system is running and maintaining the proper water flow and temperature. Shelves need to be in place. A false front placed on the shelves to represent a product load will support the air curtain and help the compressor reach the setpoint. Empty boxes can be used for this purpose. Ambient conditions need to be 75°/55% relative humidity or less

Note: At high water temperatures (between 90° and 115°F), compressors will run the full 30 minute maximum run time - discharge air temperature will get to the setpoint, but will not cut out on temperature (Setpoint – deadband, or 26° for an ID6SU-W case, for example). The case will hold proper product temperatures at these conditions.

Troubleshooting

If compressors are running the full 30-minute maximum run time and discharge air temperatures are not getting to the setpoint, check other possible defects before cutting into the refrigeration system:

Discharge air sensor location:

The discharge air sensors should be above the honeycomb, at the center of each section, in the location shown. If the sensors are in any other location, the discharge air sensor may read high, and the compressor then will not shut off even though discharge air temperature is reaching the setpoint. An external temperature probe can be used to verify the discharge air temperature.

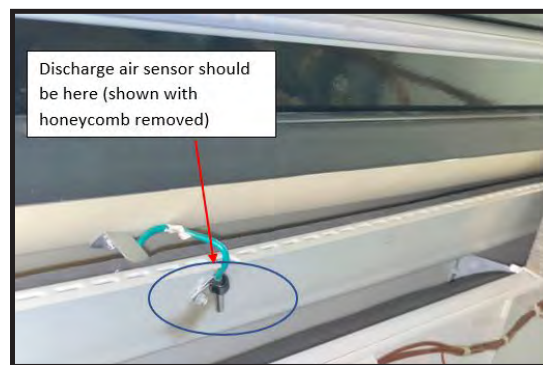
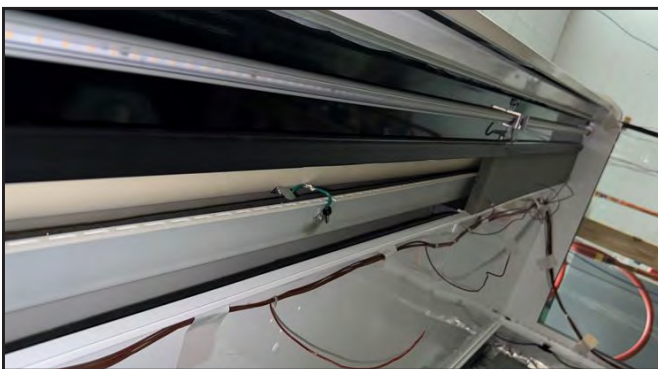

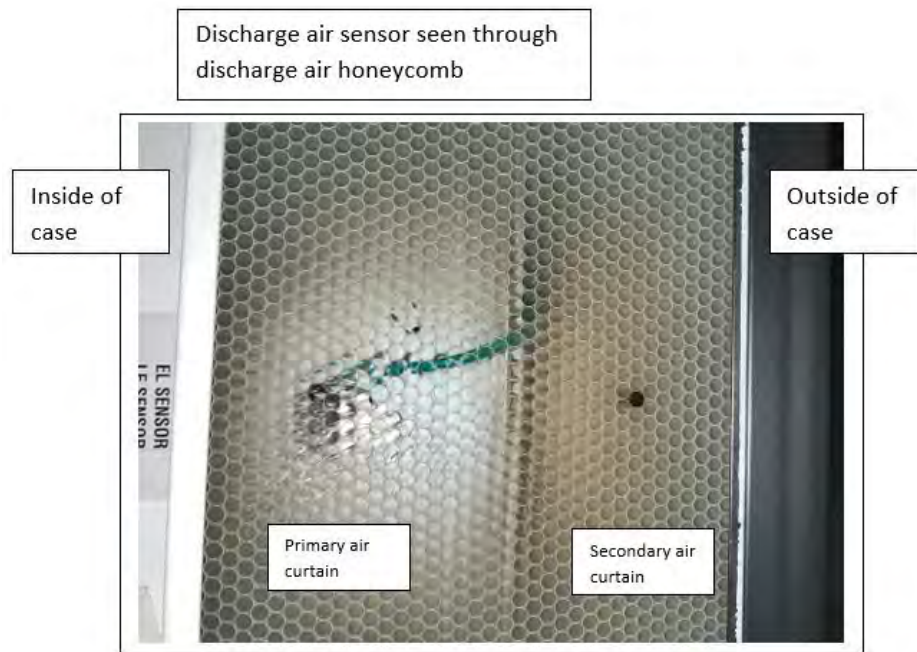

Plenum and air flue seals:

The fan plenum should be tight to the case bottom and there should be no gaps between the lower back panel and the back of the plenum.

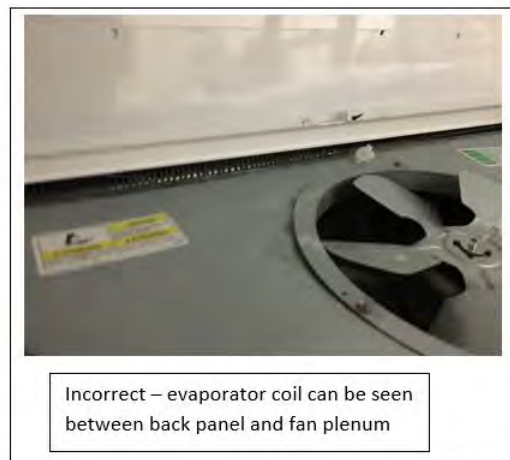

Rear air flue seams should be sealed with foil tape.



4-4

Verify that the cap tube is in contact with the suction line.



Verify that fans are running.

Verify that the correct fan speed chip is securely in the fan speed control – see data sheet for the correct fan speed.



To connect to the CoreLink WebUI refer to the CoreLink Quick Connect Guide:

https://www.hussmann.com/ns/Technical-Documents/3088251_CoreLink_QC_Guide_EN.pdf

Access the Fault Sequence Tab

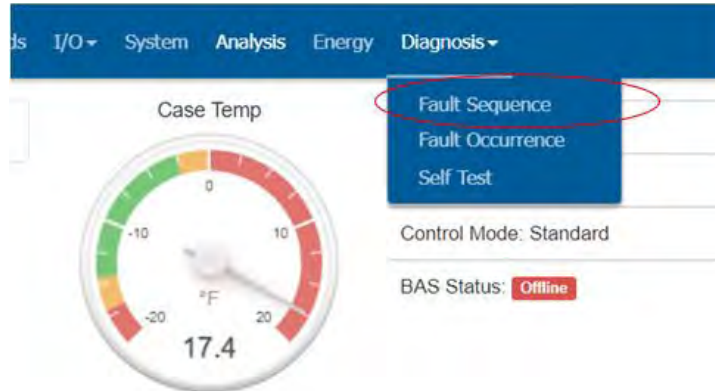

The Fault Sequence will show if the refrigeration system has a failure, and will help determine the cause of the failure. The failure will usually be accompanied by a discharge air temperature alarm.

Possible failures include:

Suction Pressure Safety Switch Alarm
High Pressure Safety Switch Alarm
Discharge Temperature Alarm

Check the CoreLink Fault sequence

If the compressor cuts out on high discharge pressure or high compressor discharge temperature alarm, this is usually caused by lack of water flow through the system or high water temperature.

Verify that:

- The water system has adequate flow and pressure
- The water inlet strainer screen is not blocked.
- The water flow valve on the outlet tube assembly is not obstructed, and has the correct cartridge for the water flowrate required.
- Water inlet temperature is less than 115°F
- Normally a water system problem will cause an alarm on all the compressors on a case.

A CoreLink suction pressure safety switch alarm on an individual compressor is an indication that there is a problem with the refrigeration system that requires service. Possible causes of the suction pressure safety switch alarm include:

1. Blocked refrigerant system

This can occur at the cap tube or distributor orifice. This will cause a suction pressure safety switch alarm to enable and then clear three times, then lock out. Then after a delay the alarm will clear and the compressor will start again. If the failure condition is still present, this will continue until the CoreLink controller permanently locks out the compressor. This is an indication that service is required to repair the blockage in the refrigeration system.

4-6

NOTE: A system with a partially blocked refrigerant system may run without alarms but have poor performance. This will be indicated by high compressor discharge temperature on the CoreLink analysis or status tab (20° higher on one compressor compared to the others on the same case while the compressor is running).

2. Low refrigerant charge due to a leak

If the compressor cuts out on the suction pressure safety switch alarm due to refrigerant loss, the suction pressure will not go back up high enough to reset. The suction pressure safety switch alarm will enable, and will not clear. This is an indication that service is required to evacuate the system, repair a leak, and then re-charge with the correct refrigerant charge.

Fault Sequence shown for suction pressure lockout due to a blocked cap tube.

3/29/2022 9:24:8	F4012	Compressor 2 Suction pressure Safety Lockout	2	Active
3/29/2022 9:23:56	F4372	Compressor 2 Permanent Suction Lockout	2	Active
3/29/2022 9:19:8	F4002	Compressor 2 Suction pressure Safety Switch Alarm	2	Clear
3/29/2022 9:19:5	F4002	Compressor 2 Suction pressure Safety Switch Alarm	2	Active
3/29/2022 9:16:50	F4002	Compressor 2 Suction pressure Safety Switch Alarm	2	Clear
3/29/2022 9:16:47	F4002	Compressor 2 Suction pressure Safety Switch Alarm	2	Active

Date and Time	Fault Code	Fault Name	Zone	Status
3/29/2022 8:59:16	F4012	Compressor 2 Suction pressure Safety Lockout	2	Active
3/29/2022 8:59:16	F4002	Compressor 2 Suction pressure Safety Switch Alarm	2	Clear
3/29/2022 8:59:14	F4002	Compressor 2 Suction pressure Safety Switch Alarm	2	Active
3/29/2022 8:56:59	F4002	Compressor 2 Suction pressure Safety Switch Alarm	2	Clear
3/29/2022 8:56:57	F4002	Compressor 2 Suction pressure Safety Switch Alarm	2	Active
3/29/2022 8:54:41	F4002	Compressor 2 Suction pressure Safety Switch Alarm	2	Clear
3/29/2022 8:54:38	F4002	Compressor 2 Suction pressure Safety Switch Alarm	2	Active
3/29/2022 8:50:7	F4002	Compressor 2 Suction pressure Safety Switch Alarm	2	Clear
3/29/2022 8:50:4	F4002	Compressor 2 Suction pressure Safety Switch Alarm	2	Active
3/29/2022 8:34:51	F4012	Compressor 2 Suction pressure Safety Lockout	2	Active

Date and Time	Fault Code	Fault Name	Zone	Status
3/29/2022 8:32:36	F4002	Compressor 2 Suction pressure Safety Switch Alarm	2	Clear
3/29/2022 8:32:32	F4002	Compressor 2 Suction pressure Safety Switch Alarm	2	Active
3/29/2022 8:25:32	F4002	Compressor 2 Suction pressure Safety Switch Alarm	2	Clear
3/29/2022 8:25:25	F4002	Compressor 2 Suction pressure Safety Switch Alarm	2	Active

Servicing

It is important that replacement parts are the same as the original equipment, and that the design of the original equipment is followed. For example, if the cap tube is replaced, the replacement cap tube must be in contact with the suction line.

If a leak is detected, follow store safety procedures.

It is the store's responsibility to have a written safety procedures in place. The safety procedure must comply with all applicable codes such as local fire department's codes.

At minimum, the following actions are required:

- Immediately evacuate all persons from the store, and contact the local fire department to advise them that a propane leak has occurred.
- Call Hussmann and/or a qualified service agent and inform them that a propane sensor has detected the presence of propane.
- Do not let any persons back into the store until the qualified service technician has arrived and that technician advises that it is safe to return to the store.
- The propane gas used in the unit has no odor. The lack of smell does not indicate a lack of escaped gas.
- A hand-held propane leak detector (“sniffer”) should be used before any repair and/or maintenance is attempted. **All repair parts must be identical models to the ones they are replacing.**
- No open flames, cigarettes or other possible sources of ignition should be used inside the building where the units are located until the qualified service technician and/or local fire department determines that all propane has been cleared from the area and from the refrigeration systems.

12 HOURS AFTER STARTUP CHECKLIST

- Check case temperature.
- Check if there is any alarm on the controller display.
- Check water connections for leaks or accumulation of water.
- Verify the fans are running.
- Check compressor's amperage, and validate with the information on serial plate.
- Check that all inspection plates and covers have been properly replaced.
- Inspect for any water accumulation due to incorrect or unsealed penetrations where electrical or other lines pass through insulated walls of the case.
- Check the water outlet temperature from each condensing unit. Water outlet temperature should be approximately 10° F (5.6° C) higher than the inlet water temperature.

▲WARNING

» Possible hazardous condition. Follow safety procedures outlined by store safety management.

CONDENSING UNIT COMPONENTS

The condensing units are equipped with a non-adjustable high pressure controls and internal compressor motor protectors.

IMPORTANT: The high pressure control will open in the event of excessive pressures; for example, the loss or reduction in condenser water flow. The high pressure control will open at approximately 450 psig and automatically resets when the pressure has decreased below 320 psig.

LOAD LIMITS

Each merchandiser has a load limit. Shelf life of perishables will be short if load limit is violated. At no time should merchandisers be stocked beyond the load limits indicated.

STOCKING

Do not block honeycomb or return air grille.

Product should not be placed inside of merchandisers until merchandiser is at proper operating temperature. Proper rotation of product during stocking is necessary to prevent product loss. Always bring the oldest product to the front and set the newest to the back.

Air discharge and return flues must remain open and free of obstruction at all times to provide proper refrigeration and air curtain performance. Do not allow product, packages, signs, etc. to block these grilles. Do not use non-approved shelving, baskets, display racks, or any accessory that could hamper air curtain performance.

Excessive ambient conditions may cause condensation and therefore sweating of doors. Facility operators should monitor doors and floor conditions to ensure safety of persons.

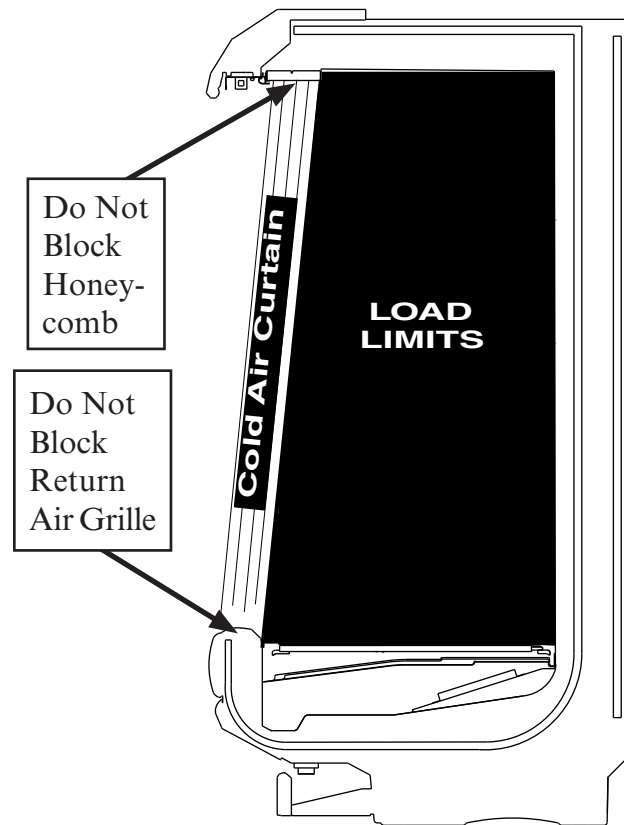

⚠ WARNING

- » Do not walk on case. Do not store items or flammable materials atop the case.

SHELF MAXIMUM WEIGHT LIMITS

Husmann merchandiser shelves are designed to support the maximum weight load limits as indicated in this table.

Exceeding these maximum weight load limits may cause damage to the shelf or shelves, damage to the merchandiser, damage to store products, and potentially create a hazardous condition for customers and staff. Exceeding the indicated maximum weight load limits constitutes misuse as described in the Husmann Limited Warranty.

Weight Limits for Merchandiser Shelving

Nominal Shelf Depth	Maximum Load Limit
12 in. (305 mm)	125 lb (56.7 kg)
14 in. (357 mm)	125 lb (56.7 kg)
16 in. (406 mm)	200 lb (90.7 kg)
18 in. (457 mm)	200 lb (90.7 kg)
20 in. (508 mm)	250 lb (113.4 kg)
22 in. (559 mm)	250 lb (113.4 kg)
24 in. (610 mm)	250 lb (113.4 kg)
Heavy Duty Beverage Shelf 16 in. (406 mm)	300 lb (136 kg)
Heavy Duty Beverage Shelf 18 in. (457 mm)	320 lb (145.1 kg)
Heavy Duty Beverage Shelf 20 in. (508 mm)	350 lb (158.8 kg)
Heavy Duty Beverage Shelf 22 in. (559 mm)	350 lb (158.8 kg)
Heavy Duty Beverage Shelf 24 in. (610 mm)	350 lb (158.8 kg)

*Shelf load limits at 0° tilt

Merchandiser Shelf Depths

	Recommended	Maximum
Narrow (37 in. Merchandiser Depths)	16 in. (406 mm)	18 in. (457 mm)
Standard (42 in. Merchandiser Depths)	22 in. (559 mm)	24 in. (610 mm)

MULTI-DECK SHELF CONFIGURATION

Shelves are individually mounted in 1 in. (25 mm) increments and have two-, three-, or four-position brackets, permitting shelves to be placed in a flat or down-tilt position (see illustration). Front product stops are recommended when shelves are placed in the down-tilt position.

Case performance will be degraded if peg shelves are used without baffles. Unauthorized specialty shelving may cause poor merchandiser performance. Consult your Husmann representative to ensure optimum performance of Husmann equipment.

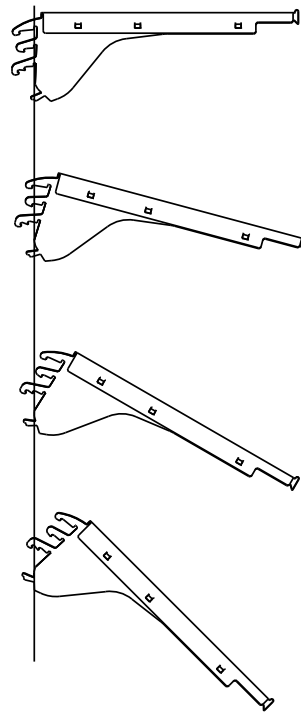

4-position Shelf

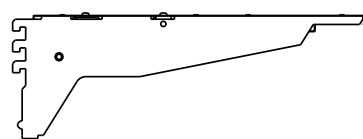

Beverage Shelf

LED FIXTURES

These merchandisers are equipped with 24 volt DC power supplies that power the LEDs. The power supplies are located in the canopy wire-way. Hussmann LEDs work well for dimming or on/off operation using an occupancy sensor (optional kits).

Shelf lights are IP67 rated for water resistance. Canopy lights are IP54 rated for water splashes.

⚠ WARNING

— LOCK OUT / TAG OUT —

» To avoid serious injury or death from electrical shock, always disconnect the electrical power at the breaker when servicing or replacing any electrical component. This includes, but is not limited to, such items as doors, lights, fans, heaters, and thermostats.

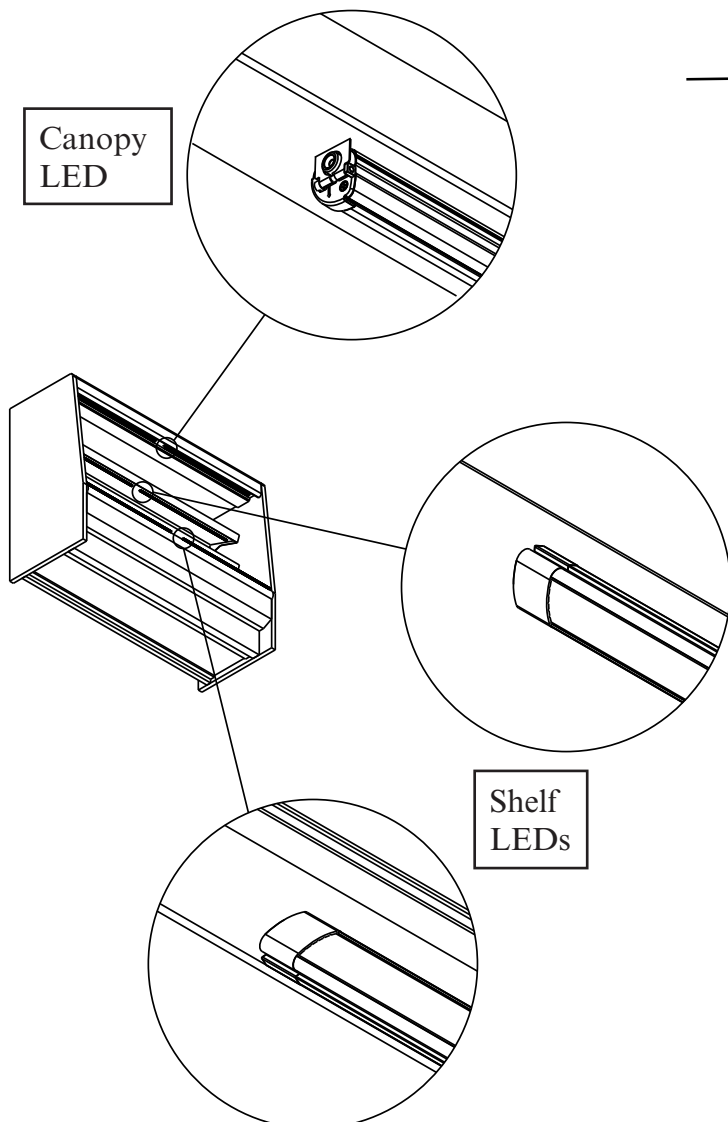

(EcoShine LED Bars Shown)

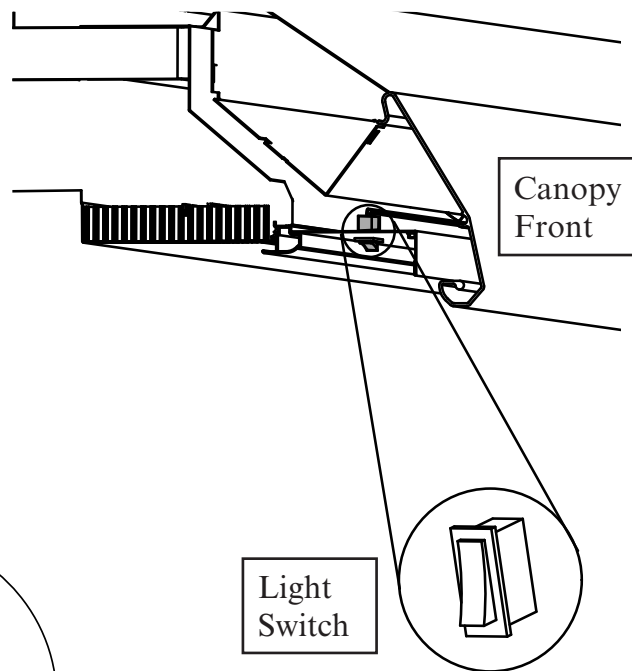

PROCEDURE FOR INSTALLING LIGHTED SHELVES

Follow these instructions to ensure good contact between male and female connectors.

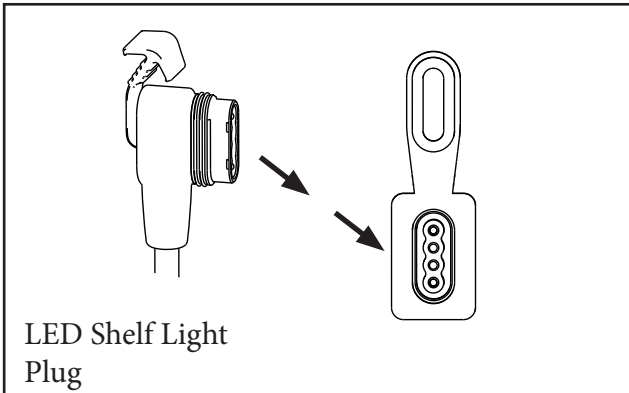

1. Remove any products from the case and place in cooler. Shut off power to the merchandiser.
2. Turn off Canopy Light Switch. Remove all packed shelves.
3. **Engage each power socket cap, and ensure that each cap is fully seated before cleaning.** Ensure the proper seating of the cap at all times when the plug is not engaged.

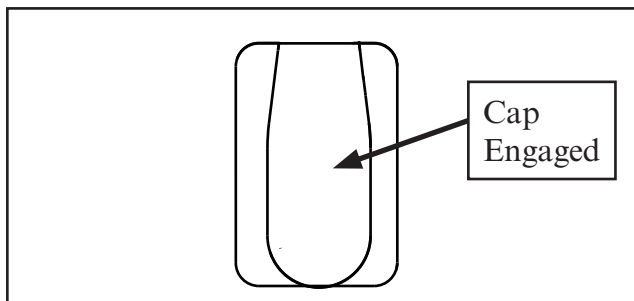

4. Clean the merchandiser as described in the *Care and Cleaning* paragraphs of **Section 5 — Maintenance**. **Keep liquid out of sockets.** (Allow merchandiser shelves to dry before turning on shelf power.)

5. Verify power to the merchandiser is turned ON. Verify that the merchandiser light switch is turned OFF. The switch is located in the canopy, on the left side.

6. Refer to the illustration at the top of the next page. Note that other models will have fewer rows of shelves. Starting from the left-hand bottom section, choose the location for the first shelf, X-1.

7. Secure the shelf in the slotted upright. Make certain that the shelf is level and that ends are in the same slot on the left and right upright. Markings on the shelf uprights indicate the proper shelf notch for each shelf location. It is important that shelf brackets be properly seated in the slotted upright.

8. Working from left to right, install the next shelf, X-2, to the right of the first shelf you installed. Always work from left to right and from the bottom up in each 8 ft (2438 mm) and 12 ft (3685 mm) merchandiser.

9. After each shelf on the bottom row is in position, be sure to remove the cap and insert the shelf connector. ***Push firmly.***

⚠ WARNING

- » Hussmann does not recommend using spray hoses or misting systems due to risk of serious injury or death from electrical shock.
- » Do not use spray hoses or misting systems on cases with shelf or rail lighting.

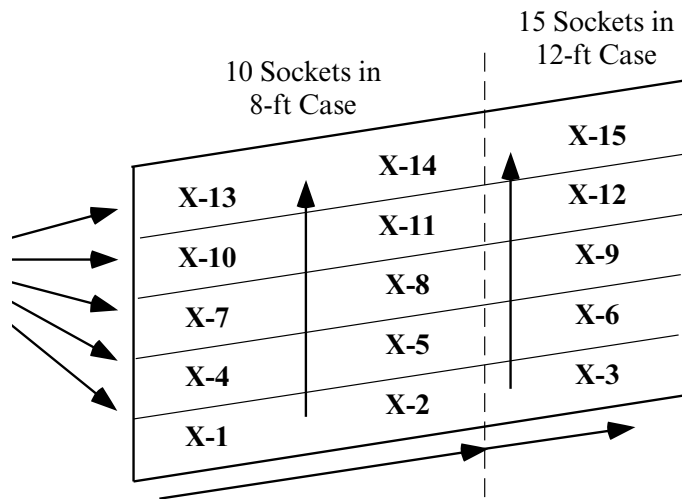

**Always work Left to Right,
and Bottom to Top**

10. Turn ON the merchandiser light switch after the entire bottom row has been installed in either 8 or 12 ft (2438 or 3658 mm) merchandisers. The shelf lights should light.

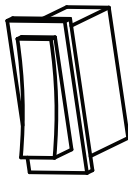

Note: Since the location for the remaining shelves, X-4 to X-15, may be directly over the rear wall receptacle, the shelf should be plugged in before engaging brackets in the uprights. The lower shelf will support the weight of the next shelf until it is plugged in. After installing each shelf, verify that its plug is properly connected to its rear wall receptacle. Continue working row by row, bottom up, left to right.

If an LED shelf light does not operate:

- Turn off light switch.
- Remove and firmly re-insert each shelf plug.
- Turn on light switch.

Important
If a shelf is plugged in and the lamp does not work, verify the case light switch is ON.

If lights do not operate after checking the items listed above, contact the installation contractor.

11. Using the row of shelves just installed as support, set the next shelf, X-4, in the desired location. Remove the cap and insert the shelf plug. Continue working left to right installing shelves X-5 and X-6.

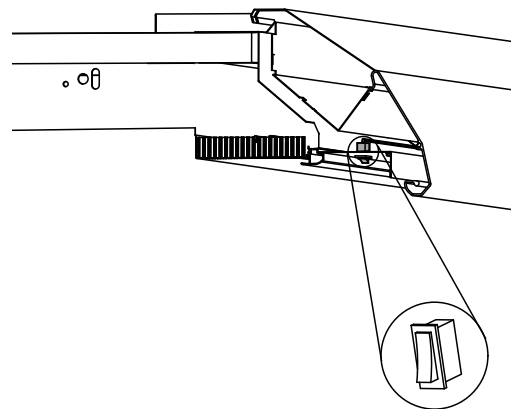

SHELF LED CLIP INSTALLATION

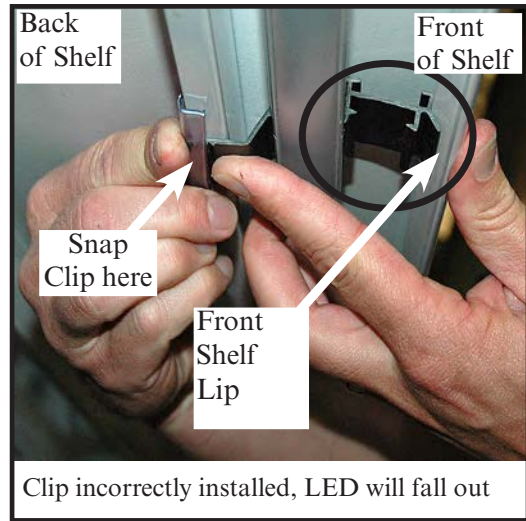
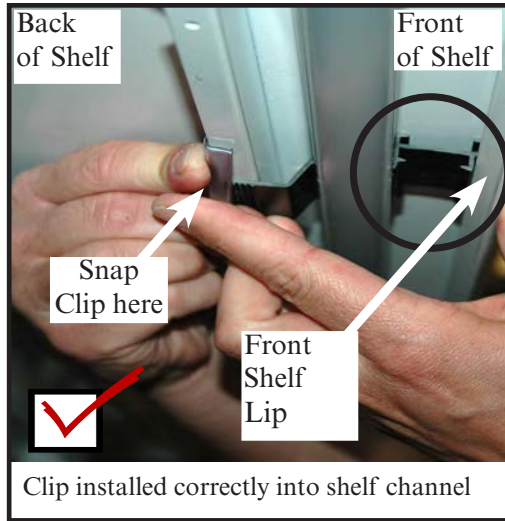

Shelf LED clips must be first inserted into the front lip underneath the shelf as shown at left. Next the retaining clip is “snapped on” to the rear of the LED clip.

PRODUCT STOP INSTALLATION

Use caution when installing Product Stops. Product stop legs must be inserted at an angle. When product leg goes through the shelf, it must rest **BEHIND** the LED shelf light as shown below.

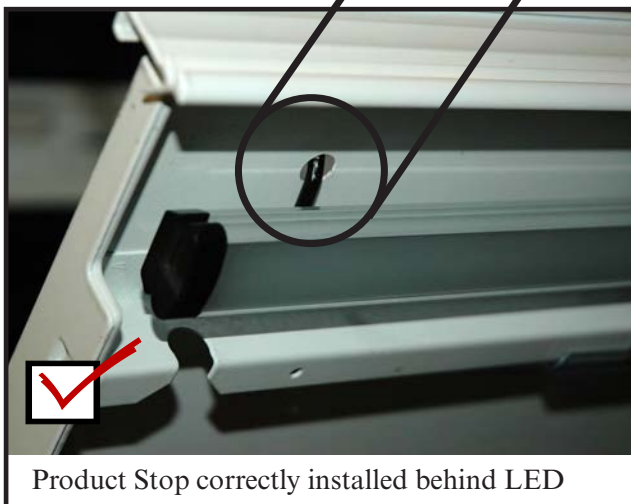
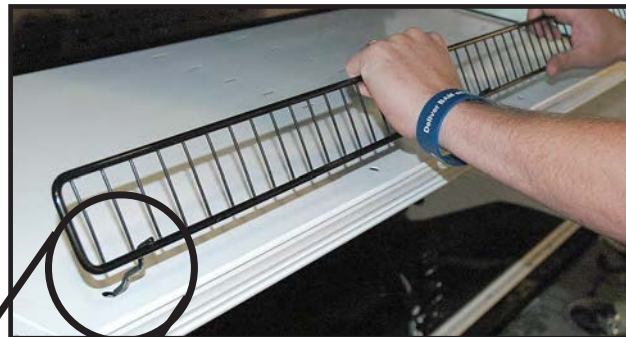

INSTALLING FDA/NSF REQUIRED THERMOMETER

The thermometer requirement does not apply to display refrigerators intended for bulk produce (refer to page 1-1). Please note that the tape cannot be exposed after installation.

This thermometer may not be required or provided in other countries. Check for local code requirements.

This is an NSF-7 & US FDA Food Code Required Thermometer

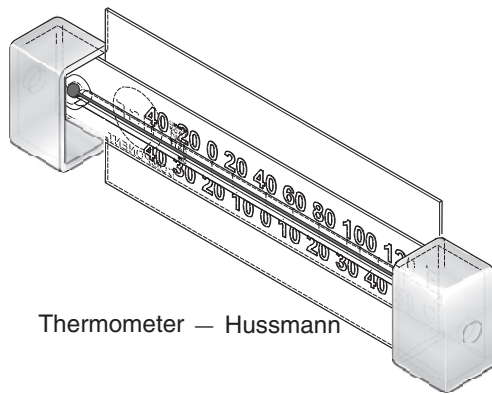

Thermometer — Hussmann

Hussmann Corporation • 12999 St. Charles Rock Road • Bridgeton, MO 63044-2483
U.S. & Canada 1-800-922-1919 Mexico 1-800-890-2900 www.hussmann.com
© 2013 • Hussmann Corporation

Suggested Mounting Locations in Single Deck Glass Front Merchandisers

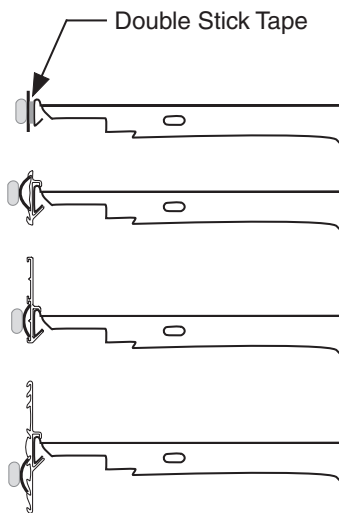
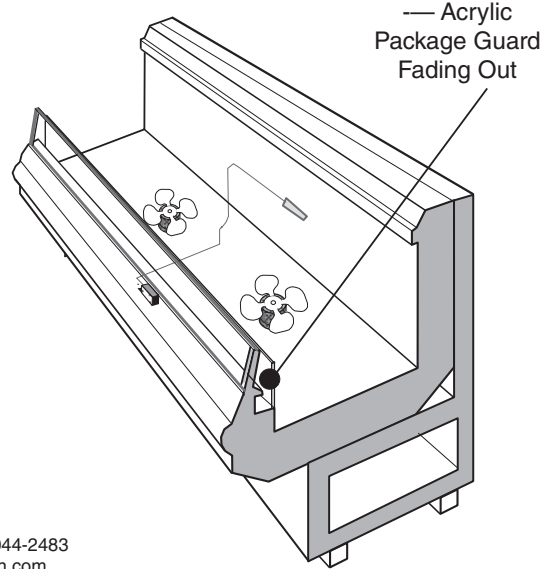

Flexible Plastic Fits in Price Tag Moldings

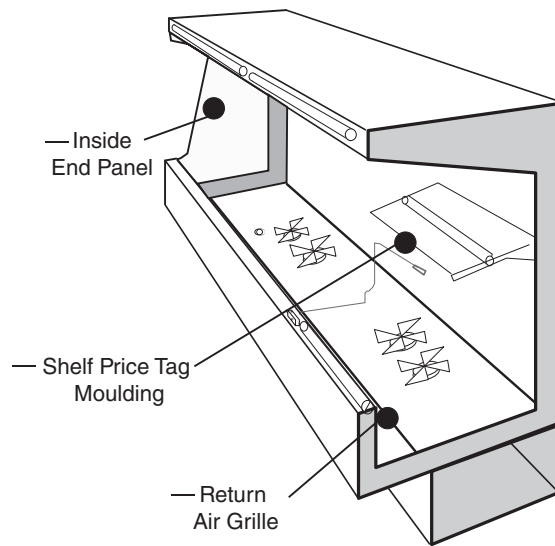

Suggested Mounting Locations in Multi-deck Merchandisers

Important – Please read!

This thermometer is provided in response to United States
Food and Drug Administration (US FDA) Food Code [<http://www.fda.gov/>]
and
National Sanitation Foundation (NSF / ANSI) Standard 7 [<http://www.nsf.org/>]

Each installation will be different depending on how the unit is stocked, shopping patterns in the department and ambient conditions of the store. The suggested locations provided herein are possible locations. It is the responsibility of the purchaser / user to determine the location within the food storage area of the unit that best meets the code requirements above.

The thermometer may need to be moved several times to find the warmest location. Mounting options include flexible plastic for price tag molding application, magnet applied to back of flexible plastic for steel end wall, and double stick tape. Tape must not be exposed after installation.

Questions about either code should be addressed to local agencies or other appropriate officials.

**Keep with merchandiser
or give to store manager.**

DO NOT DESTROY.

MAINTENANCE

IDENTIFICATION OF CASE PARTS

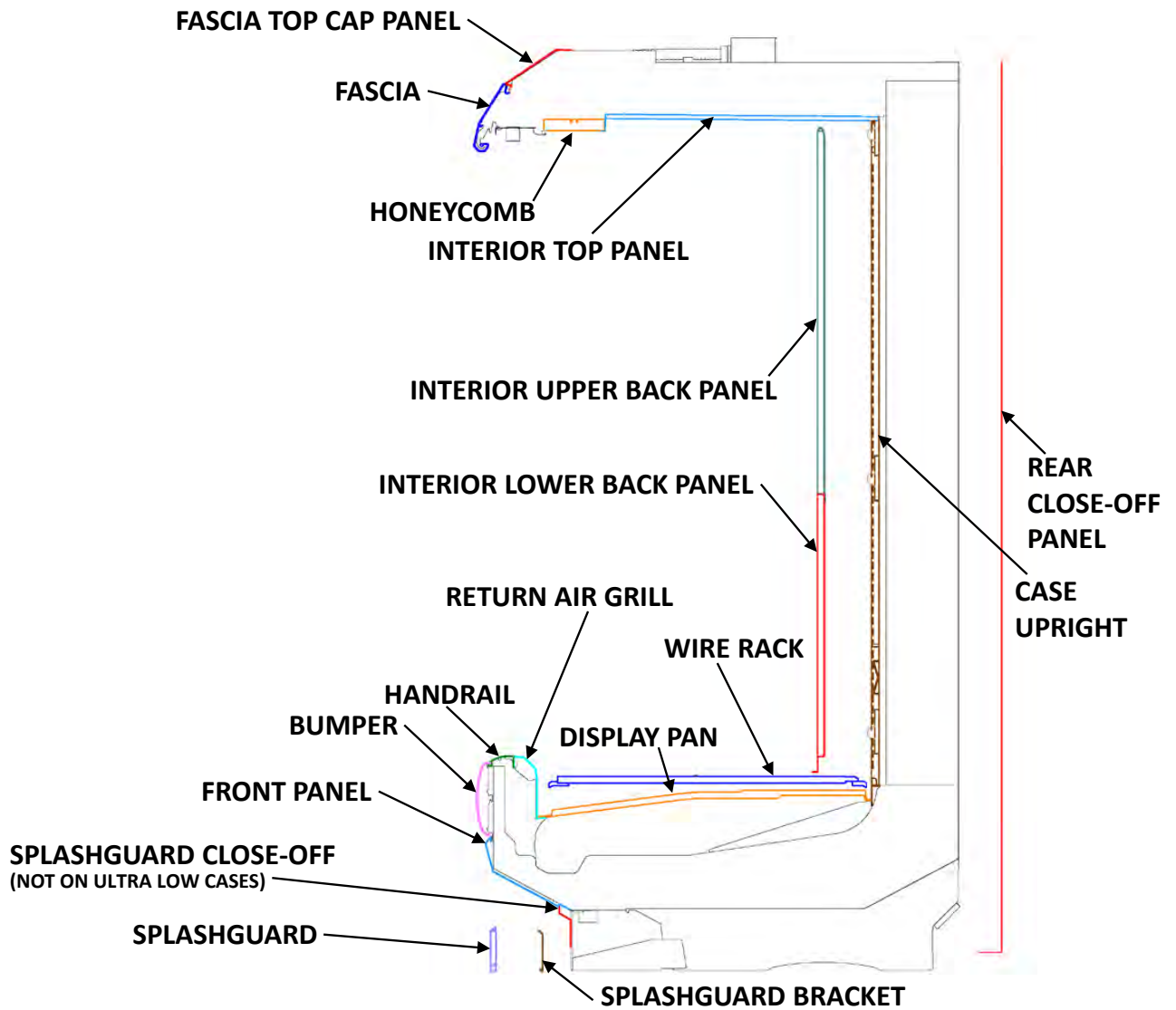

CARE AND CLEANING

Long life and satisfactory performance of any equipment is dependent upon the care it receives. To ensure long life, proper sanitation and minimum maintenance costs, these merchandisers should be thoroughly cleaned, all debris removed and the interiors washed down as part of a regular store sanitation schedule.

Fan Plenum

To facilitate cleaning, the fan plenum is hinged. After cleaning be sure the plenum is properly lowered into position or product loss will result due to improper refrigeration.

Fan motor harness plug must be securely connected. Do not disconnect fan motor harness plug for cleaning or maintenance procedures.

To lift the fan plenum:

1. Gently bend the bottom of the hinge pin arm away from the plenum to release the retainer from the coil support.
2. Rotate the hinge pin 180° so that the arm is pointed upwards.
3. Slide the hinge pin out and away from the plenum.

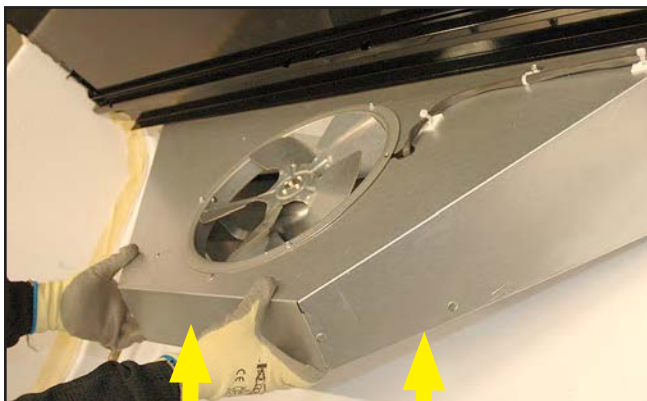

Lift up Fan Plenum. Use chain to hook up fan plenum to facilitate cleaning.

The plenum can also be removed, but this is not necessary for routine cleaning.

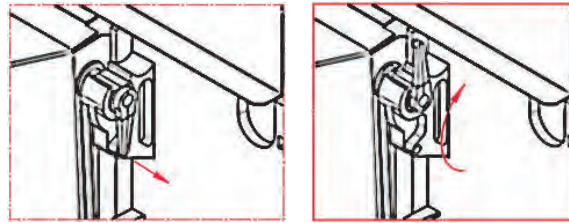

1. Flip the arm up and pull arm out to release the plenum.

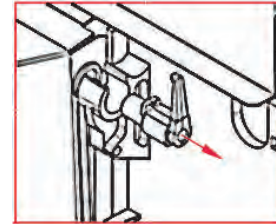

Removable Return Air Grilles

The return air grilles may be removed to facilitate cleaning. Lift a four foot section up and out as shown below.

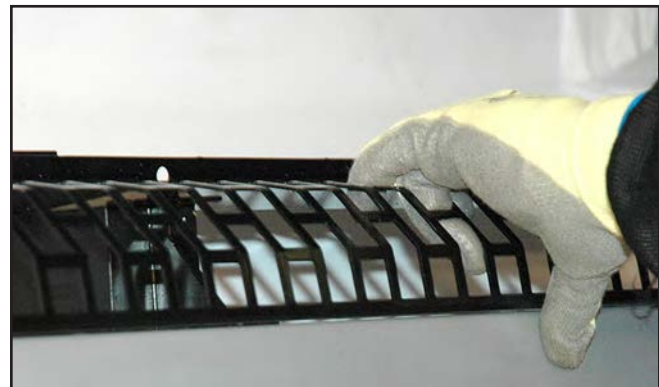

⚠ WARNING

» All case cleaning and maintenance procedures should be performed with the power disconnected at the breaker.

Fascia Panels

The exterior of the fascia panels should be cleaned with a mild detergent and warm water.

Do not use ammonia-based products to clean optional acrylic panels. Never use abrasive cleansers or scouring pads.

EXTERIOR SURFACES

The exterior surfaces must be cleaned with a mild detergent and warm water to protect and maintain their attractive finish.

NEVER USE ABRASIVE CLEANERS OR SCOURING PADS.

INTERIOR SURFACES

The interior surfaces may be cleaned with most domestic detergents, ammonia based cleaners and sanitizing solutions will not harm the surface. Always read and follow the manufacturer's instructions when using any cleaning product.

Inspect all LED connections and plug/ receptacles for signs of arcing. Replace any component that shows signs of arcing. Make sure all unused receptacles have close-off covers securely attached.

Do Not:

- Abrasive cleansers and scouring pads, as these will mar the finish.
- Coarse paper towels on coated glass.
- Ammonia-based cleaners on acrylic parts.
- Do not spray water from a hose directly on the canopy lights or fans.
- Solvent, oil or acidic based cleaners on any interior surfaces.

• A pressure nozzle on canopy lights, shelf lights or any other electrical connection. Do not use water pressure beyond what is supplied from the potable water system and spray nozzle (ie Do not use a pressure washer.)

Steps:

- First turn off refrigeration, then disconnect electrical power. Turn off case power at breaker. Make sure all unused light receptacles have their close-off covers securely attached.
- Remove the product and all loose debris to avoid clogging the waste outlet.
- Store product in a refrigerated area such as a cooler. Remove only as much product as can be taken to the cooler in a timely manner.
- Thoroughly clean all surfaces with soap and warm water. Do not use steam or high water pressure hoses to wash the interior. These will destroy the merchandisers' sealing causing leaks and poor performance.
- Lift hinged fan plenum for cleaning. Hook chain in rear panel to secure plenum during cleaning. Be sure to reposition the fan plenum after cleaning merchandiser.
- Take care to minimize direct contact between fan motors and cleaning or rinse water.
- Rinse with warm water, but do not flood. Never introduce water faster than the waste outlet can remove it.
- Allow merchandisers to dry before resuming operation.
- Wipe down lighted shelves with a damp sponge or cloth so that water does not enter the light channel.
- After cleaning is completed, turn on power to the merchandiser.

RECOMMENDED CLEANING INSTRUCTIONS

The directions below are recommended cleaning instructions for Insight cases and should not be used as a substitute for the store's regular maintenance schedule. Follow all local and national health codes. Cleanliness of the case encourages long-lasting life of the equipment. This guide lists some of the key areas of the cases that require cleaning to help maintain the overall appearance and performance of the equipment and keep it free of debris. The cases may need additional cleaning, especially in high traffic areas, dusty areas and during unusually extended periods of use of the equipment.

Rotate the type of detergent and sanitizer used. For example, rotate the use of an ammonia based, a chlorine based and/or a peroxide based detergent and sanitizer to ensure micro-organisms do not become resistant to a single detergent or sanitizer.

CLEANING INSTRUCTIONS

Weekly or Monthly

1. Remove product; store it in another case or suitable walk-in cooler.
2. Remove wire racks and bottom pans. Cleaning them in the case with warm water and a soap solution, then rinse and set aside.
3. Turn off case power at breaker.
4. Flip up the fan plenum assembly to provide more room for cleaning in the case if necessary.
5. Remove all loose debris and food particles that may clog drain. Check drain to make sure it is not clogged. Do not force items down drain, use the drain catch to remove debris and dispose.

6. Remove honeycomb and price display molding.
7. Clean all surfaces including shelves and honeycomb by spraying down water (preferably warm) and mild detergent. Use a brush or cleaner pad if necessary to aid in penetrating dirt.
8. Rinse all surfaces with water, then spray with a sanitizer. Rinse off sanitizer with clean water using a hose. Allow surfaces to air dry, since wiping would defeat the purpose of sanitizing.
9. Replace all internal parts carefully so that they seat properly. This is necessary for proper case operation.
10. Turn ON power to the fans at breaker.
11. Replace product.

CLEANING INSTRUCTIONS

Quarterly or Semiannually

1. Remove product; store it in another case or suitable walk-in cooler.
2. Remove wire racks and bottom pans. Cleaning them in the case with warm water and a soap solution, then rinse and set aside.
3. Turn off case power at breaker.
4. Flip up the fan plenum assembly to provide more room for cleaning in the case if necessary.
5. Remove all loose debris and food particles that may clog drain. Check drain to make sure it is not clogged. Do not force items down drain, use the drain catch to remove debris and dispose.
6. Remove honeycomb and price display moulding.

7. Clean all surfaces including shelves and honeycomb by spraying down water (preferably warm) and mild detergent. Use a brush or cleaner pad if necessary to aid in penetrating dirt.
8. Remove all the shelves and set aside then remove the back panels.
9. Clean the backside of the back panels in the case as you remove them.
10. Clean the newly exposed surfaces and the coil by spraying down with water (preferably warm) and a mild detergent solution.
11. Rinse the newly exposed surfaces and the coil with water then spray with a sanitizer. Allow surfaces to air-dry, since wiping would defeat the purpose of sanitizing.
12. Replace the back panels and shelves.
13. Rinse all surfaces with water, then spray with a sanitizer. Allow surfaces to air-dry since wiping would defeat the purpose of sanitizing.
14. Replace all remaining internal parts carefully so that they seat properly. This is necessary for proper case operation.
15. Turn ON power to the fans at breaker.
16. Replace product.

⚠ WARNING

- » Do not use mechanical devices or other means to accelerate the defrosting process.
- » Do not use electrical appliances inside the food storage compartments of the case(s).

CLEANING HONEYCOMB ASSEMBLIES

Honeycombs should be cleaned every six months, or depending on store environment the honeycombs may need to be cleaned more often. Dirty honeycombs will cause cases to perform poorly.

The honeycombs may be cleaned with a vacuum cleaner. Soap and water may be used if all water is removed from the honeycomb cells before replacing. Be careful not to damage the honeycombs.

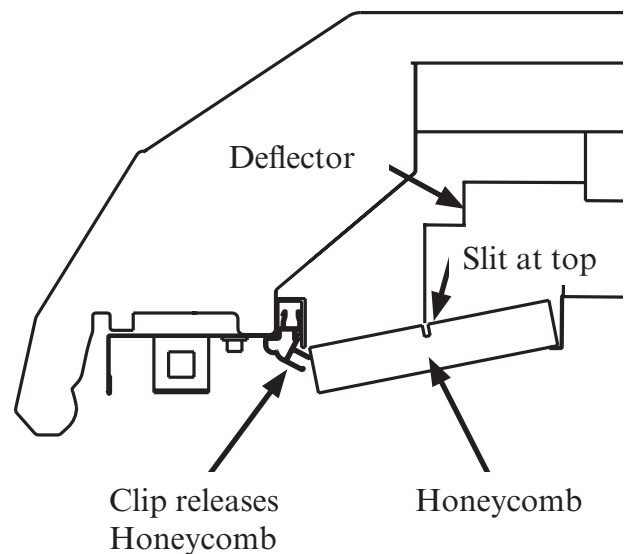

1. Remove honeycomb by pulling clip as shown above.
2. Clean and dry the honeycomb.
3. Honeycomb is symmetrical.
4. After cleaning, replace honeycomb. Ensure clip is centered and engaged along full-length of honeycomb.

Damaged honeycomb must be replaced.

BOTTOM LINER REPAIR

Insight merchandisers have bottom liners, which are made of a high density polyethylene material (HDPE). Repairs may be made if the bottom liner becomes damaged. Follow the illustrations at right to repair the liner.

For minor repairs:

Minor repairs consist of deep scratches and tears that are no more than 1/8 inch thick.

1.) Remove all product, and disconnect power to the case that is to be serviced. Locate the damaged area of the liner. Clear and clean the area, then wipe it dry.

2.) Use an electric hot air gun to heat the tear. **Heat to 600°F (316°C)**. Solder the tear with 1/8 inch filler welding rod, made from HDPE. Ensure no voids or skips in completed bead.

3.) Let the area cool, then buff the area flat. A 5-inch, 80 grit disc works well for this. The repair is now complete.

For major repairs:

1.) For repairs with larger size gashes or holes, a piece of HDPE may be cut into a square as shown in **(F)** at right. (The square HDPE shown in the photo is white for clarity.)

2.) Remove all product and disconnect power to the case that is to be serviced. Locate the damaged area of the liner. Clear and clean the area, then wipe it dry. Ensure no voids or skips in completed bead.

3.) The square is then tacked at all four corners using the hot air gun.

4.) Solder with 1/8 inch filler welding rod around the perimeter of the HDPE square.

5.) Buff the area flat if needed. The repair is now complete.



Forthoff Mini Electric Hot Air Gun
(120V 1300W)

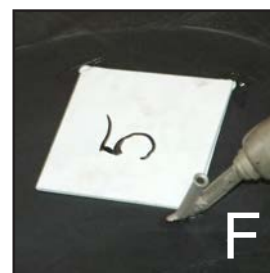
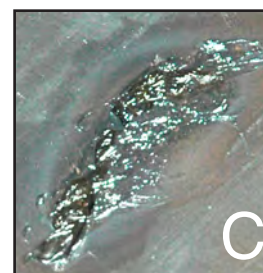
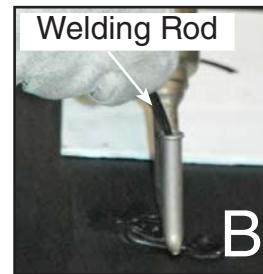
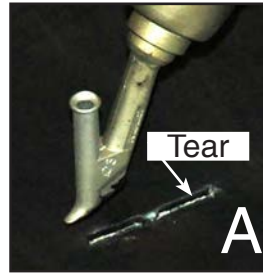

⚠ WARNING

- » Always wear protective clothing when operating hot air gun, such as fire resistant gloves and arm guards. Hot air gun operates at extremely high temperature and could cause serious burns. Always have fire protective gear on hand in case of fire.
- » To avoid serious injury or death from electrical shock, always disconnect the electrical power at the breaker when servicing or replacing any electrical component. This includes, but is not limited to, such items as doors, lights, fans, heaters, and thermostats.

CLEANING COILS

NEVER USE SHARP OBJECTS AROUND COILS!

Use a soft brush or vacuum brush to clean debris from coils. *Do not puncture coils!* Do not bend fins. Contact an authorized service technician if a coil is punctured, cracked or otherwise damaged.

ICE in or on the coil indicates the refrigeration and defrost cycle is not operating properly. Contact an authorized service technician to determine the cause of icing, and to make adjustments as necessary. To maintain product integrity, move all product to a cooler until the unit has returned to normal operating temperatures.

CLEANING STAINLESS STEEL FRONT RAILS

Use non-abrasive tools, and always polish with grain of the steel.

Use alkaline chlorinated or non-chlorine containing cleaners. Do not use cleaners containing salts as this may cause pitting and rusting of the stainless steel finish.

Clean frequently to avoid build-up of hard, stubborn stains. Rinse and wipe dry immediately after cleaning. Never use hydrochloric acid (muriatic acid) on stainless steel.

REMOVING SCRATCHES FROM BUMPER

Most scratches and dings can be removed using the following procedure.

- Use steel wool to smooth out the surface area of the bumper.
- Clean area.
- Apply vinyl or car wax and polish surface for a smooth glossy finish.

CLEANING UNDER MERCHANDISERS

Remove splashguards not sealed to floor. Use a vacuum with a long wand attachment to remove accumulated dust and debris from under the merchandiser.

WARNING

- » Do not use **HOT** water on **COLD** glass surfaces. This can cause the glass to shatter and could result in personal injury. Allow glass fronts, ends and service doors to warm before applying hot water.

CLEANING MIRRORS

Mirrors are sheets of clear glass that have very thin reflective and protective coatings applied to one side. These coatings are susceptible to deterioration if certain cleaning solutions and even water are allowed to come in contact with them. Every precaution should be taken to keep all liquids away from the coated side of the mirrors. **IF LIQUIDS ARE ALLOWED TO FLOW ALONG THE FACE SIDE OF THE MIRROR TO ITS EDGE, THE LIQUID CAN SEEP UP BETWEEN THE COATING AND THE GLASS, CAUSING SERIOUS DAMAGE.**

To Help Prolong the Life of the Mirrors:

- Use only mild cleaning solutions that do not leave residue, such as a weak (10%) solution of vinegar and water.
- Do NOT spray liquids on the mirrors. Away from food, dampen the cleaning cloth, then use the cloth to wipe the mirror.
- Wipe water from the mirrors immediately to prevent difficult to remove water spots and also to prevent the water from reaching the mirror's edge.
- Never use dirty cloths, scrapers or any other abrasive materials for cleaning.

⚠ WARNING

- » Product will be degraded and may spoil if allowed to sit in a non-refrigerated area.
- » All products in the case should be removed and stored in a cooler at the appropriate temperature before cleaning the interior of the case.

REMOVING INTERIOR BACK PANELS

The interior back panels may be removed for cleaning and to gain access to the evaporator coils. Remove the rear interior back panels as follows:

1. Disconnect the electrical power to the merchandiser.
2. Unplug shelf lights and insert plastic protective cap. Remove shelving.
3. Remove the lower panel first: lift the panel up, then pull forward and out.
4. Remove the top panel.



5. Replace panels in reverse order, starting with the top panel.

SERVICE

Before Beginning Any Service or Repair:

Use a hand-held propane leak detector (“sniffer”) to ensure no propane is present in the immediate area, the inside of the display case and the inside of the refrigeration system. Keep the area clear of all customers and non-essential or unauthorized personnel.

Verify that all repair parts are identical models to the ones they are replacing. Failure to do so can result in an explosion, death, injury and property damage.

Brazing must not begin before all propane has been cleared from the immediate area, the inside of the displays case and the inside of the refrigeration system.

If a leak is detected, follow store safety procedures.

It is the store’s responsibility to have a written safety procedures in place. The safety procedure must comply with all applicable codes such as local fire department’s codes. At minimum, the following actions are required:

- Immediately evacuate all persons from the store, and contact the local fire department to advise them that a propane leak has occurred.
- Call Hussmann and/or a qualified service agent and inform them that a propane sensor has detected the presence of propane.
- Do not let any persons back into the store until the qualified service technician has arrived and that technician advises that it is safe to return to the store.

DANGER

- » Only Hussmann service technicians or technicians qualified to handle R-290 (propane) refrigerant should service or repair this R-290 (propane) equipment. Failure to follow instructions can result in an explosion, death, injury and property damage.

- The propane gas used in the unit has no odor. The lack of smell does not indicate a lack of escaped gas.
- A hand-held propane leak detector (“sniffer”) should be used before any repair and/or maintenance is attempted. All repair parts must be identical models to the ones they are replacing.
- No open flames, cigarettes or other possible sources of ignition should be used inside the building where the units are located until the qualified service technician and/or local fire department determines that all propane has been cleared from the area and from the refrigeration systems.

REPLACING REFRIGERATION SYSTEM COMPONENTS

! DANGER

» Only Hussmann service technicians or technicians qualified to handle R-290 (propane) refrigerant should service or repair this R-290 (propane) equipment. Failure to follow instructions can result in an explosion, death, injury and property damage.

4. Connect hose to an evacuated recovery tank. Open refrigeration gauges and recovery tank.



CLEANING AND FLUSHING

See Section 2, Page 2-17.

STEPS TO RECOVER REFRIGERANT

1. Make sure you are in a well ventilated area before making any service or repair to the refrigeration system.
2. Disconnect all power sources from the system. Some systems may have more than one plug or power supply.
3. Tap system with line tap valves, attaching gauges to the high and low sides of the system.

5. With the suction valve in vacuum, the refrigerant will be recovered into the recovery tank.
6. Once recovered, close the tank valve and remove the gauge from the tank and connect nitrogen tank to the system to purge it with nitrogen.
7. Pull vacuum to a minimum of 200 microns or lower.



**refrigeration
line tapping
valve**

CHARGING

A calibrated scale with +/-2 gram accuracy must be used to charge the system. The charge amount is shown on the serial plate. No gas charge adjustments are allowed. When connecting hoses between the refrigeration system, manifold gauges, and refrigerant cylinder, ensure that the connections are secure and there are no potential sources of ignition nearby. Ensure that contamination of different refrigerants does not occur when using charging equipment. Use dedicated hoses to service R-290 (propane) refrigeration systems. Hoses or lines should be as short as possible to minimize the amount of refrigerant contained in them. Ensure that the refrigeration system is properly grounded prior to charging the system with refrigerant to avoid the potential for static build-up.

Extreme care must be taken to not overfill the refrigeration system. After charging, carefully disconnect the hoses; try to minimize the amount of refrigerant that is released. Further leak check the service ports, hoses, refrigerant tanks. The service ports shall be checked for leaks using a hydrocarbon leak detector with a sensitivity of 3 grams/year (0.106 oz/year) leak rate.



Once it is ensured that the service port does not leak, braze it closed. Remove all service ports. If a Schrader valve was used on the compressor service tube, it must be removed and the previous steps followed to braze the service tube shut.

WARNING

» Follow leak check procedures carefully in order to ensure service tubes are not leaking before brazing.

REPLACING FAN MOTORS

Fan control electronics are electrostatic sensitive (ESD). If the case is equipped with an optional fan speed selector (FSS), use a grounding kit before handling.

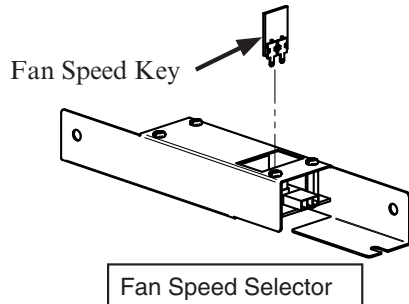

⚠ WARNING

— LOCK OUT / TAG OUT —

» To avoid serious injury or death from electrical shock, always disconnect the electrical power at the breaker when servicing or replacing any electrical component. This includes, but is not limited to, such items as doors, lights, fans, heaters, and thermostats.

See cross section for location of evaporator fans. Should it ever be necessary to service or replace the fan motors or blades be certain that the fan blades are re-installed correctly.

To access and replace fan motor:



1. Turn off case power at breaker.
2. Remove bottom display pans.
3. Unpack new motor/harness assembly and set aside outside of case.
4. Remove screws holding existing fan motor bracket assembly to plenum, and remove assembly from plenum.
5. Unlock and Unplug existing motor harness from harness; remove existing motor.
 - A. Rotate locking ring counterclockwise to unlock.
 - B. Pull connector straight out to disengage.
6. Taking care to avoid any existing moisture in the case, IMMEDIATELY connect and lock new motor harness as follows:

Correct connection procedure for main fan motor harness connector:

- A. Align arrows and push connector into position.
- B. Rotate locking ring until all three arrows are aligned in the secured position.

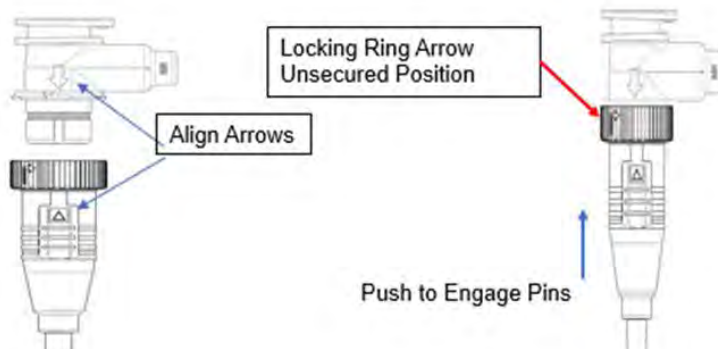

- C. Push straight in to engage pins.
- D. Turn locking ring until all three arrows are aligned.

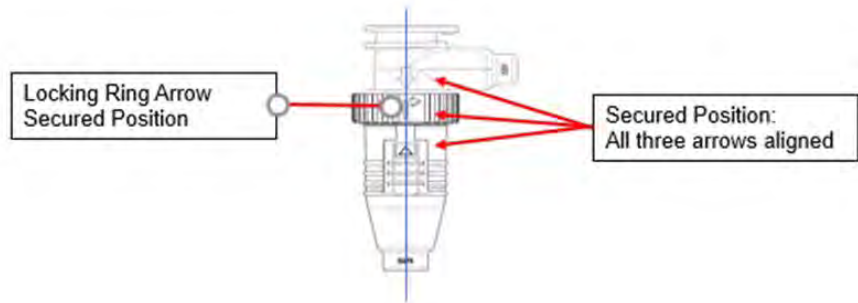

Remember. Push to engage, then twist to secure.

⚠️ WARNING

STOP - DO NOT UNPLUG

The fan motor harness plug **MUST** be properly secured in order to perform at its IP67 rating. The component is a twist lock style connector with an alignment arrow to validate a secure connection. This connection should **ONLY** be disconnected / connected by a qualified contractor and **ONLY** in the event of a fan motor replacement. The fan motor harness plug should not be disconnected/connected in performing any other cleaning, service or repair. Refer to the installation, operation and services manual for sequence of repair. All case cleaning & maintenance procedures should be performed with the power disconnected at the breaker. Failure to adhere to these instructions can lead to damage to the unit and creates a risk of flammability.

7. Place new fan motor assembly back into plenum, and reinstall screws to secure.
8. Turn on power.
9. Verify that motor is working and blade is turning in the correct direction.
10. Close air gaps under fan plenum. Warmer air moving into refrigerated air reduces effective cooling. If the plenum does not rest against the case bottom without gaps, apply foam tape to the bottom of the fan plenum to reduce improper air movement. Use silicone sealant to close other gaps.
11. Replace display pans. Bring merchandiser to operating temperature before restocking.

REPAIRING ALUMINUM COIL

! DANGER

» Only Hussmann service technicians or technicians qualified to handle R-290 (propane) refrigerant should service or repair this R-290 (propane) equipment. Failure to follow instructions can result in an explosion, death, injury and property damage.

The aluminum coils used in Hussmann merchandisers may be field repaired. Materials are available from local refrigeration wholesalers. As discussed in the previous section, good refrigeration practice must be followed when servicing R-290 (propane) equipment. However, because R-290 (propane) is flammable, there are some important differences. Please refer to the previous section about ignition sources, system purging, leak testing, evacuation and charging. All these procedures must be followed when attempting to repair aluminum coil.

Hussmann recommends the following solders and technique:

Solders

Aladdin Welding Products Inc.
P.O. Box 7188
1300 Burton St.
Grand Rapids, MI 49507
Phone: 1-800-645-3413
Fax: 1-800-645-3414

X-Ergon

1570 E. Northgate
P.O. Box 2102 Irving, TX 75062
Phone: 1-800-527-9916

NOTE:

Aladdin 3-in-1 rod melts at 732°F (389°C)
X-Ergon Acid core melts at 455°F (235°C)

Technique:

1. Locate Leak.
2. Remove all pressure
3. Brush area under heat
4. Use Prestolite torch onle. Number 6 tip.
5. Maintain separate set of stainless steel brushes and USE ONLY ON ALUMINIUM.
6. Tin surface around area.
7. Brush tinned surface UNDER HEAT, thoroughly filling the open pores around leak.
8. Repair leak. Let aluminum melt solder, NOT the torch.
9. Don't repair for looks. Go for thickness.
10. Perform a leak check.
11. Wash with water.
12. Cover with a good flexible sealant such as butyl. **No silicone based sealant may be used.**



HUSSMANN[®]

To obtain warranty information
or other support, contact your Hussmann
representative.

Please include the model and
serial number of the product.