

# HUSSMANN® *Excel*

## *Self-Contained Medium Temperature*

Bakery Merchandisers



**IMPORTANT**  
Keep in store for future reference!

## *Installation & Service Manual*

Shipped With Merchandiser  
Data Sheets

P/N 0518279\_B  
January 2022





## BEFORE YOU BEGIN

Read these instructions completely and carefully.



### ANSI Z535.5 DEFINITIONS

-  • **DANGER** – Indicate[s] a hazardous situation which, if not avoided, will result in death or serious injury.
-  • **WARNING** – Indicate[s] a hazardous situation which, if not avoided, could result in death or serious injury.
-  • **CAUTION** – Indicate[s] a hazardous situation which, if not avoided, could result in minor or moderate injury.
- **NOTICE** – Not related to personal injury – Indicates[s] situations, which if not avoided, could result in damage to equipment.

The information contained in this document is the property of Hussmann Corporation and shall not be used in whole or in part without written permission.

### **CAUTION**

This manual was written in accordance with originally prescribed equipment that is subject to change. Hussmann reserves the right to change all or part of the equipment for future stores such as, but not limited to, controllers and electrical specifications.

### **WARNING**

Do not use mechanical devices or other means to accelerate the defrosting process.

Do not use electrical appliances inside the food storage compartments of the case(s).

### **WARNING**

Case ventilation openings must be clear of any obstructions. Do not damage the refrigerant circuit.

### **WARNING**

#### **PERSONAL PROTECTION EQUIPMENT (PPE)**

Only qualified personnel should install and service this equipment. Personal Protection Equipment (PPE) is required whenever installing or servicing this equipment. Always wear appropriate PPE as required by OSHA regulations, as well as all other federal, state and local codes. PPE may include, but is not limited to, safety glasses, gloves, protective boots or shoes, long pants, and a long-sleeve shirt. Observe all precautions on tags, stickers, labels and literature attached to this equipment.

### **WARNING**

**Proper Field Wiring and Grounding Required!**  
Failure to follow code could result in death or serious injury. All field wiring **MUST** be performed by qualified personnel. Improperly installed and grounded field wiring poses **FIRE** and **ELECTROCUTION** hazards. To avoid these hazards, you **MUST** follow requirements for field wiring installation and grounding as described in NEC and your local/state electrical codes.

### **WARNING**

#### **— LOCK OUT / TAG OUT —**

To avoid serious injury or death from electrical shock, always disconnect the electrical power at the main disconnect when servicing or replacing any electrical component. This includes, but is not limited to, such items as controllers, electrical panels, condensers, lights, fans, and heaters.

### **WARNING**

Case tipping may occur if cases are not properly leveled and secured.

## TABLE OF CONTENTS

<p><b>ANSI DEFINITIONS</b> ..... ii</p> <p><b>INSTALLATION</b></p> <p>Husmann Product Control ..... 1-1</p> <p>Shipping Damage ..... 1-1</p> <p>Shortages ..... 1-1</p> <p>Location ..... 1-1</p> <p>Unloading ..... 1-2</p> <p>Exterior Loading ..... 1-2</p> <p>Merchandisers Shipped with Ends ..... 1-2</p> <p>Shipping Braces ..... 1-2</p> <p>Merchandise Leveling ..... 1-3</p> <p>Serial Plate Location ..... 1-4</p> <p>Casters and Leg Levelers ..... 1-4</p> <p>Install Return Air Grilles ..... 1-5</p> <p>Splashguards and Panels ..... 1-5</p> <p style="padding-left: 20px;">Install Splashguard Brackets ..... 1-5</p> <p style="padding-left: 20px;">Install End Panels ..... 1-6</p> <p style="padding-left: 20px;">Install End Splashguard ..... 1-6</p> <p style="padding-left: 20px;">Install Front Panel ..... 1-6</p> <p>Install Front Product Stop ..... 1-8</p> <p>Install Optional Light Bar Kit ..... 1-9</p> <p><b>ELECTRICAL / REFRIGERATION</b></p> <p>Merchandise Electrical Data ..... 2-1</p> <p>Power Cord ..... 2-2</p> <p>Electrical Outlet ..... 2-3</p> <p>Refrigerant ..... 2-3</p> <p>Refrigeration Thermostat ..... 2-3</p> <p>Compressor ..... 2-4</p> <p>Defrost Time Clock Operation ..... 2-4</p> <p>Waste Outlet and Water Seal ..... 2-4</p>	<p><b>START UP / OPERATION</b></p> <p>Start Up ..... 3-1</p> <p>Load Limits ..... 3-1</p> <p>Stocking ..... 3-1</p> <p>Installing FDA/NSF Required Thermometer ..... 3-2</p> <p><b>MAINTENANCE</b></p> <p>Care and Cleaning ..... 4-1</p> <p style="padding-left: 20px;">Exterior Surfaces ..... 4-1</p> <p style="padding-left: 20px;">Interior Surfaces ..... 4-1</p> <p style="padding-left: 40px;"><b>Do NOT Use:</b> ..... 4-1</p> <p style="padding-left: 40px;"><b>Do:</b> ..... 4-1</p> <p style="padding-left: 20px;">Cleaning Shelf Support and Grilles ..... 4-2</p> <p>Cleaning Under Fan Plenum ..... 4-2</p> <p>Cleaning Honeycomb Assemblies ..... 4-2</p> <p>Removing Interior Back Panels ..... 4-3</p> <p>Cleaning Stainless Steel Surfaces ..... 4-3</p> <p>Cleaning Coils ..... 4-4</p> <p>Cleaning Evaporator Pan ..... 4-4</p> <p>Cleaning Under Merchandisers ..... 4-6</p> <p>Removing Scratches from Bumper ..... 4-6</p> <p><b>SERVICE</b></p> <p>Replacing Fan Motors and Blades ..... 5-1</p> <p>Replacing Nosing Anti-Sweat Heater ..... 5-2</p> <p>Replacing Fluorescent Lamps ..... 5-3</p> <p>Replacing Lamp Holders and End Caps ..... 5-3</p> <p>Front Glass Adjustment ..... 5-4</p> <p>Replacing Electronic Ballasts ..... 5-4</p> <p>Replacing Damaged Drain Fitting ..... 5-5</p> <p>Repairing Aluminum Coil ..... 5-6</p> <p><b>WARRANTY</b></p>
---	---

## REVISION HISTORY

**REVISION B** — January 2022  
Added Coil Note, Page 4-4

**REVISION A** — December 2010  
Original Issue



This warning does not mean that Husmann products will cause cancer or reproductive harm, or is in violation of any product-safety standards or requirements. As clarified by the California State government, Proposition 65 can be considered more of a 'right to know' law than a pure product safety law. When used as designed, Husmann believes that our products are not harmful. We provide the Proposition 65 warning to stay in compliance with California State law. It is your responsibility to provide accurate Proposition 65 warning labels to your customers when necessary. For more information on Proposition 65, please visit the California State government website.

## INSTALLATION

### HUSSMANN PRODUCT CONTROL

The serial number and shipping date of all equipment is recorded in Hussmann's files for warranty and replacement part purposes. All correspondence pertaining to warranty or parts ordering must include the serial number of each piece of equipment involved. This is to ensure the customer is provided with the correct parts.

### SHIPPING DAMAGE

All equipment should be thoroughly examined for shipping damage before and during unloading.

This equipment has been carefully inspected at our factory. Any claim for loss or damage must be made to the carrier. The carrier will provide any necessary inspection reports and/or claim forms.

Separately packaged accessories such as kits and shelves should be carefully unpacked. Check for damage before discarding packaging.

#### Apparent Loss Or Damage

If there is an obvious loss or damage, it must be noted on the freight bill or express receipt and signed by the carrier's agent; otherwise, the carrier may refuse claim.

#### Concealed Loss Or Damage

When loss or damage is not apparent until after equipment is uncrated, retain all packing materials and submit a written request to the carrier for inspection within 15 days from receipt of equipment.



**CAUTION**

Do not walk or put heavy objects on case.

### SHORTAGES

Check your shipment for any possible shortages of material. If a shortage should exist and is found to be the responsibility of Hussmann, notify Hussmann. If such a shortage involves the carrier, notify the carrier immediately and request an inspection. Hussmann will acknowledge shortages within ten days from receipt of equipment.

### LOCATION

These merchandisers are designed for displaying products in air conditioned stores where temperature is maintained at or below the ANSI / NSF-7 specified level and relative humidity is maintained at or below 55%.

Placing refrigerated merchandisers in direct sunlight, near hot tables or near other heat sources could impair their efficiency.

Like other merchandisers, these are sensitive to air disturbances. Air currents passing around merchandisers will seriously impair their operation. Do NOT allow air conditioning, electric fans, open doors or windows, etc. to create air currents around the merchandisers.

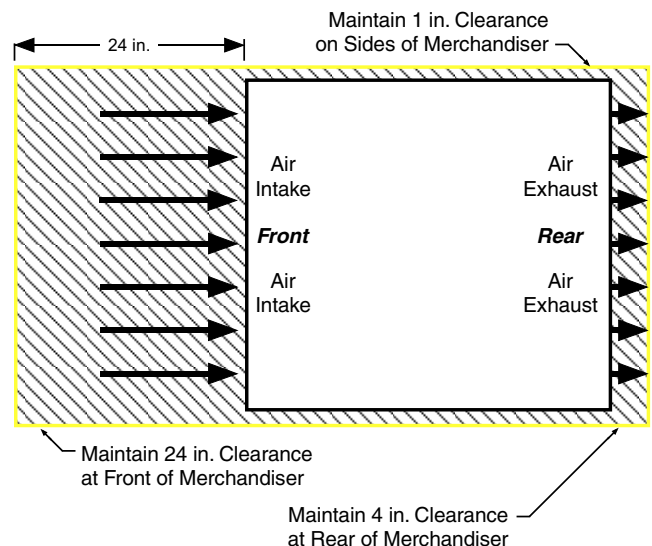

Product should always be maintained at proper temperature. This means that from the time the product is received, through storage, preparation and display, the temperature of the product must be controlled to maximize the life of the product.

The exterior frames of these merchandisers provide space for air circulation. However, in high ambient conditions, sweating may still occur. If this happens, install a method of forced ventilation such as a fan or ventilation kit.

BE SURE TO POSITION SELF-CONTAINED MERCHANDISERS PROPERLY. Self-contained models have vented base panels to allow air circulation through the condensing unit.

Allow for a minimum 4 in. clearance from walls, merchandisers, and any other large objects near the merchandiser's back side. Blocking or restricting air flow will adversely affect performance and may damage the refrigeration system.

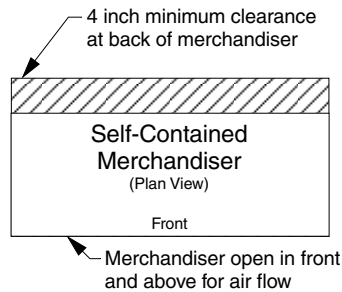

Merchandiser(s) must be free of obstruction in front and above to maintain proper air flow. There is no spacing requirement at sides of merchandiser.

**⚠ WARNING**  
 Do NOT remove shipping crate until the merchandiser is positioned for installation.

### UNLOADING

Move the merchandiser as close as possible to its permanent location. Remove the top of the crate and detach walls from each other. Lift crate from the skid. Unbolt the merchandiser from the skid.

The merchandiser can now be lifted off the crate skid. **Lift only at the base of skid!** Remove any braces and/or skids attached (blanket wrapped merchandiser may have skids). Improper handling may cause damage to the merchandiser when unloading. To avoid damage:

1. Do not drag the merchandiser out of the trailer. Use a Johnson bar (mule).
2. Use a forklift or dolly to remove the merchandiser from the trailer.

### EXTERIOR LOADING

**Do NOT walk on top of merchandisers** or damage to the merchandisers and serious personal injury could occur. THEY ARE NOT STRUCTURALLY DESIGNED TO SUPPORT EXCESSIVE EXTERNAL LOADING such as the weight of a person. Do not place heavy objects on the merchandiser.

### MERCHANDISERS SHIPPED WITH ENDS INSTALLED

Be careful not to damage the factory installed ends while moving the merchandiser. Make sure that tools are positioned past the end and beneath the model's support bar.

### SHIPPING BRACES

Move the merchandiser close to its permanent location, and then remove all packaging. Remove all separately packed accessories such as kits and shelves. Remove the shipping bolts attached to the shipping braces on each side of the merchandiser. Discard these long bolts.

Open the parts bag(s) taped to the inside of each end.

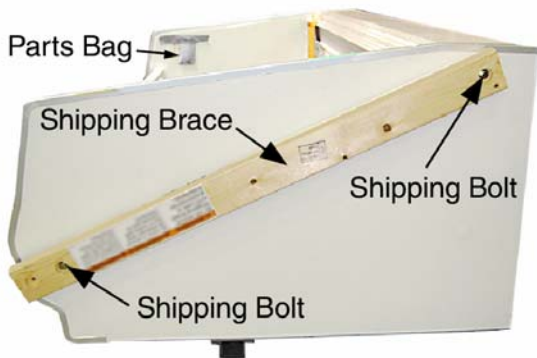

Fasten the washers and bolts to the threaded inserts on the outside of each end. Install plug button caps over end bolt holes.

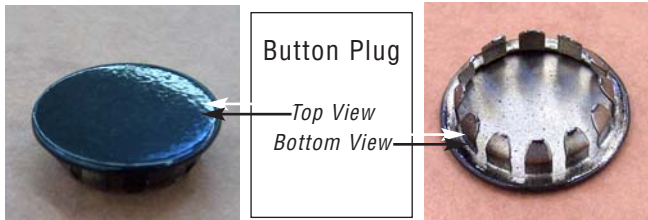

1. Check floor where merchandisers are to set to see if it is level. Determine where the highest part of the floor is. Merchandisers will be leveled off this point.
2. Using store legend, measure off and mark on floor the exact dimensions of the merchandiser footprint. Snap chalk lines for front and back position of base rail. Mark location of each joint front and back. Use a transit to find the highest point along both lines. Mark the difference, then place the appropriate number of shims required to maintain high-point level.

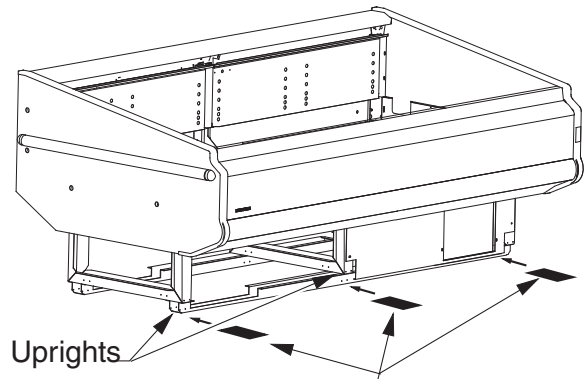

Install Shims under Rails at Uprights Only

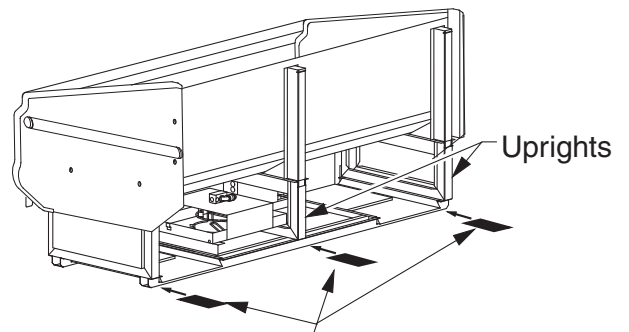

Install Shims under Rails at Uprights Only

### MERCHANDISER LEVELING

Merchandiser(s) must be installed level to ensure proper operation of the refrigeration system, and to ensure proper drainage of defrost water.

**It is imperative that merchandisers be leveled from the front to back and side to side. Leveling the merchandiser correctly will solve most operating problems.**

### SERIAL PLATE LOCATION

Direct a flashlight through the return air grille to locate the serial plate. **BE SURE TO POSITION WIDE ISLAND MERCHANDISER FRONTS PROPERLY.** The front of self-contained merchandiser is readily identified by the location of the serial plate affixed to the inside of the left front assembly.

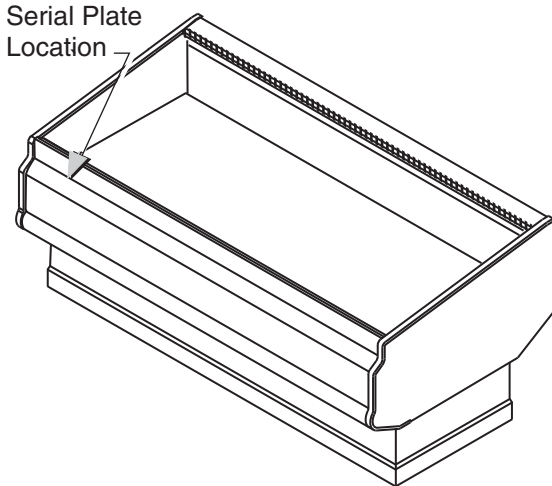

If the merchandiser has standard leg levelers, use an 18 mm open end wrench to screw down the levelers at each front corner so that the front is also level from end-to-end. At this point, check to see if the merchandiser is level front-to-rear. If it is not, turn each front corner leveler up or down the same amount of turns until the merchandiser is level front-to-rear.

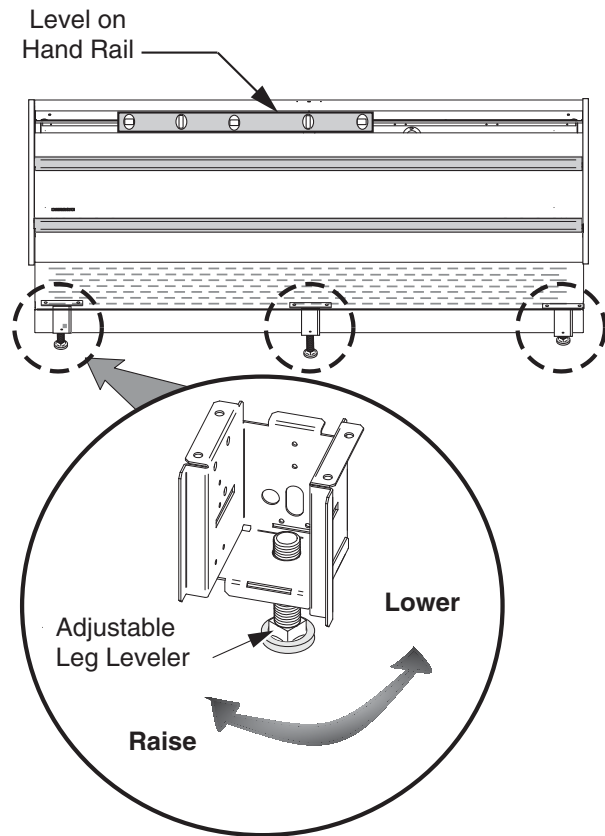

### CASTERS AND LEG LEVELERS

The merchandiser may be equipped with optional casters and optional leg levelers. If the merchandiser has optional casters as shown below, use the brake to lock the merchandiser in place.

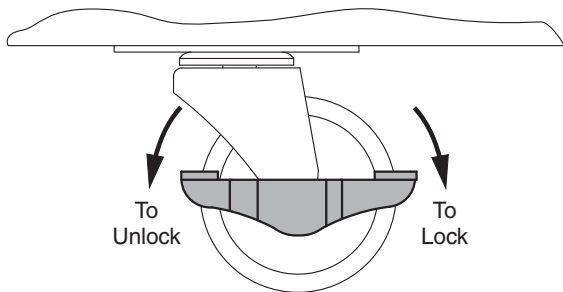



### INSTALL RETURN AIR GRILLES

Remove the return air grilles that are packed inside of the merchandiser, and install them in the fitted slots below the display racks as shown below.



### SPLASHGUARDS AND PANELS

Ensure the merchandiser has been leveled and all electrical and refrigeration work is complete before installing splashguards and panels. Refer to Section 2 for electrical and refrigeration information.

See page 1-7 for an exploded view of how brackets, panels and splashguards fit onto the merchandiser.

### Install Splashguard Brackets

Position splashguard brackets first. Remove the splashguard brackets from the plastic bag shipped with the merchandiser. Position the brackets on the merchandiser level to the floor. Each bracket has a 1½ in. (38 mm) slot at the rear of the bracket where it attaches to the merchandiser. Tighten screws to secure the brackets.

**NOTE:** The longer brackets are used at the front of the merchandiser. The shorter brackets are used at the sides of the merchandiser.

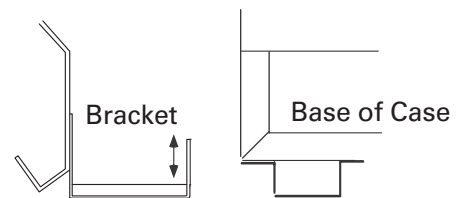

**Install End Panels:**

1. Position the end panels over the outside of the splashguard bracket and align the mounting holes as shown.
2. Fit the tabs from the top of the end panel into the slots.
3. Fasten with supplied sheet metal screws.

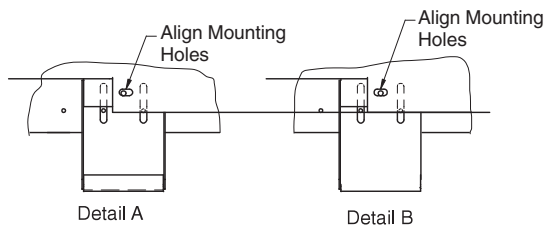
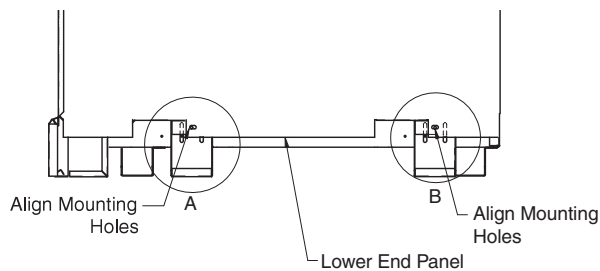
**Install End Splashguard:**

1. Unpack supplied splashguard and panel kit.
2. Check to be sure that all splashguard brackets are level with the floor.
3. Position top of splashguard over the top edge of the end bracket as shown on next page.
4. Fasten with supplied sheet metal screws.
5. Align the slot of end splashguard assembly with screw hole locations on splashguard bracket. Fasten two supplied sheet metal screws.

**Install Front Splashguard:**

1. Position top of splashguard over the top edge of the end bracket as shown.
2. Fasten with supplied sheet metal screws.

**Install Front Panel:**

1. Position the lower front panel with the top angled as shown in the illustration below.
2. The tabs extending from the upper front panel assembly are designed to fit into the slots on the top of the lower front panel.
3. Metal splashguards are to be fastened with sheet metal screws. Align screws with mounting holes..

All panels must be secured to merchandiser prior to operation

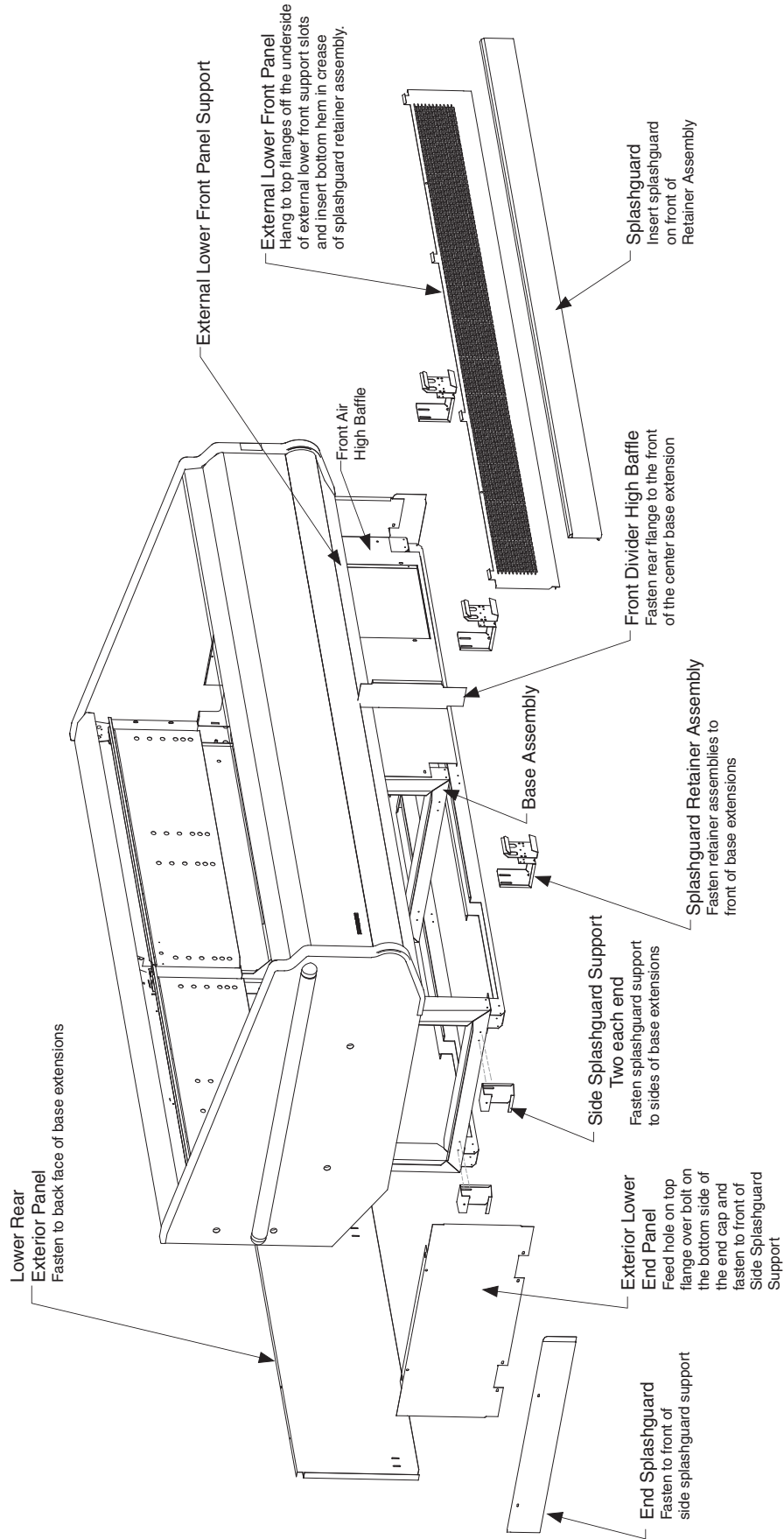

## 1-8 REFRIGERATION / ELECTRICAL

### INSTALL FRONT PRODUCT STOP (Not All Models)

Optional acrylic or wire front product stops are packed inside of the merchandiser. Refer to the illustrations to install product stop.

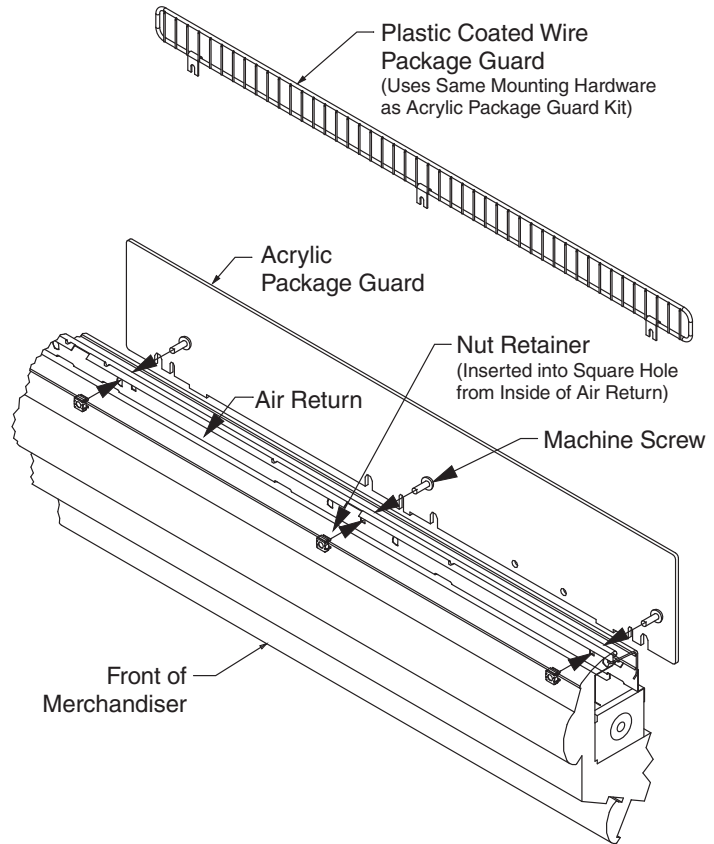
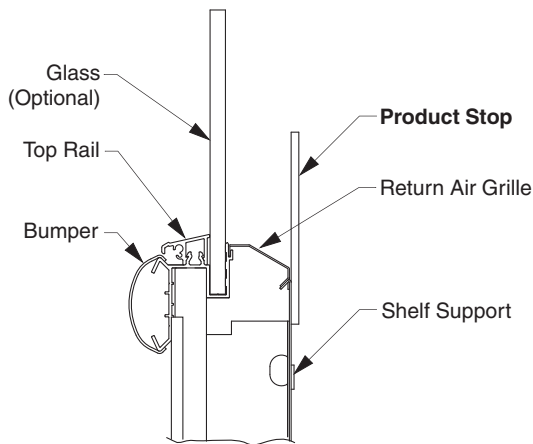

### OPTIONAL LIGHT BAR KIT INSTRUCTION

#### Parts List

Item No.	Quantity	Description
<b>8 Ft</b>		
1.	3	Mounting Bracket
2.	3	Tube Assembly
3.	6	Hex Head Sheet Metal Screw #10 x 3/4
4.	16	Flat Washer 1/4
5.	2	Anti-short Bushing
6.	1	Light Fixture Assembly
7.	1	Conduit, 120 in. Length
8.	6	Truss Head Sheet Metal Screw #8 x 3/8
9.	1	Connector 90°
10.	4	Truss Head Machine Screw 1/4 - 20 x 1/4
11.	4	Hex Nut 1/4 - 20 Stainless Steel

**Before beginning installation,** carefully unpack and inspect the Light Bar Kit making sure there is no breakage or damage.

**Note:** Make sure that Light Bar Kits are installed before placing cases in lineup.

**Caution:** Remove fasteners from studs and reattach to one bracket at a time. Failure to do this can cause damage to the case.

**1** Remove Hex Nuts/Washers from studs on rear of case. Fasten the **Light Bar Mounting Brackets -1** to the rear upright frame assemblies by sliding the holes over the studs and fastening using the same nuts and washers.

**2** When attaching brackets make sure that the brackets are fastened to the inside of each upright (see illustrations for locations).

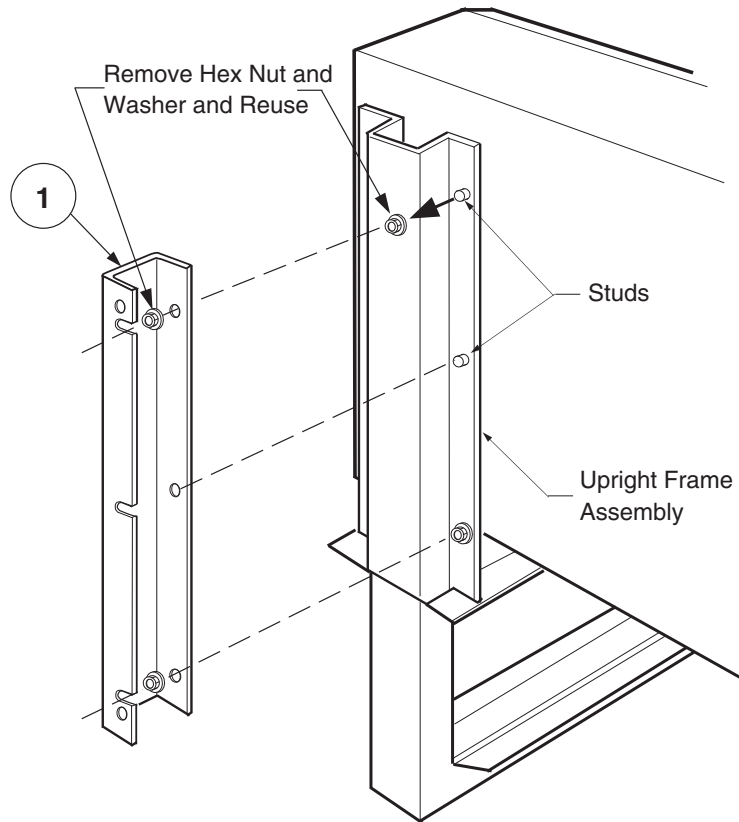

Left Rear of Merchandiser

**Installing Mounting Brackets to Upright Frame Assembly**

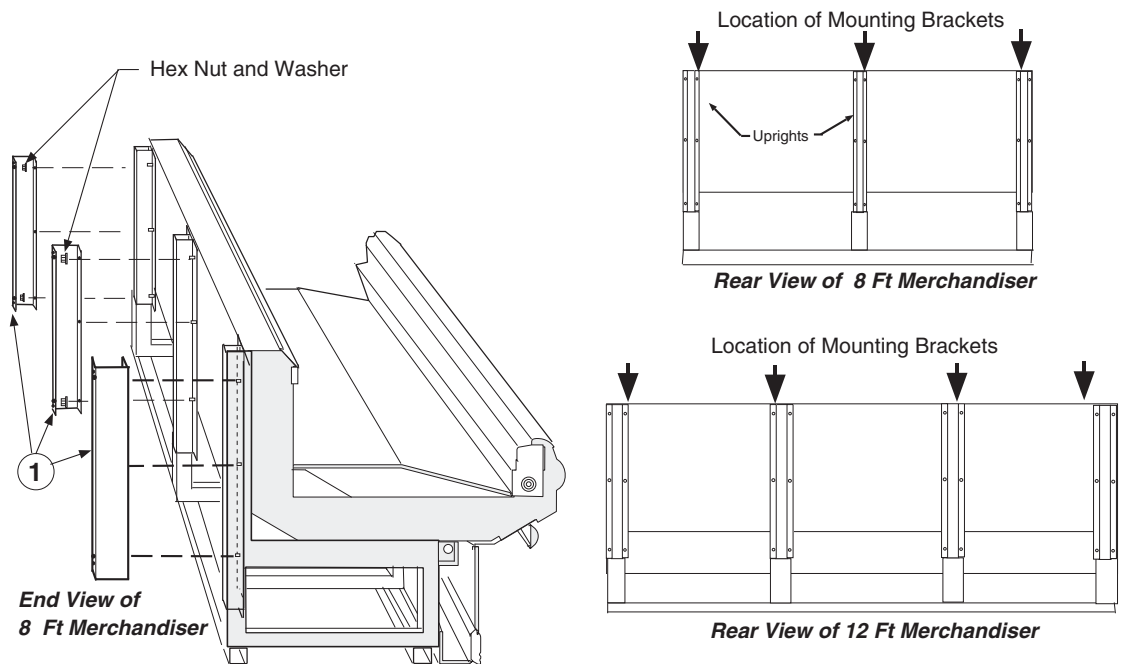

**Location of Mounting Brackets on Upright Frame Assemblies**

- 3** Fasten **Tube Assembly – 2** to the Mounting Brackets using **Screws – 3** and **Flat Washers – 4**.

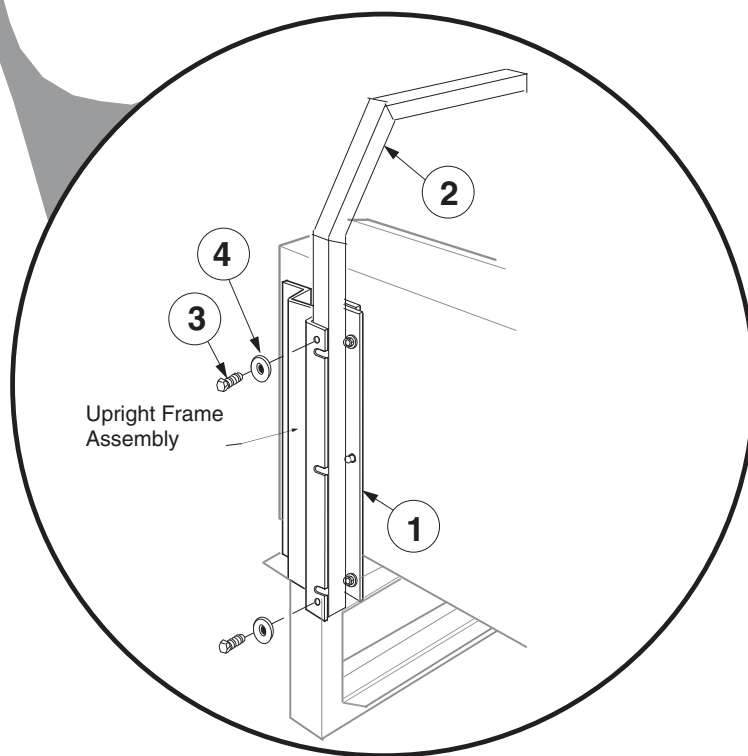
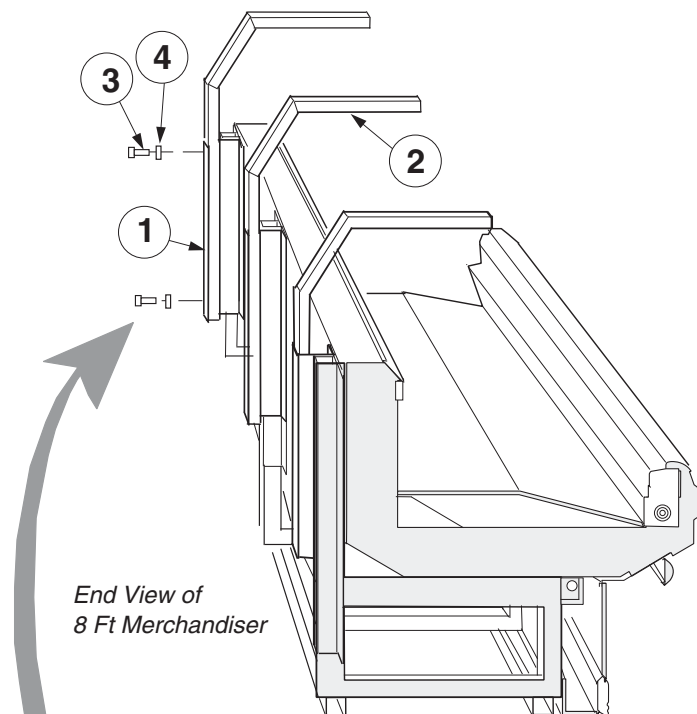

**Installing Tube Assembly to Mounting Brackets**

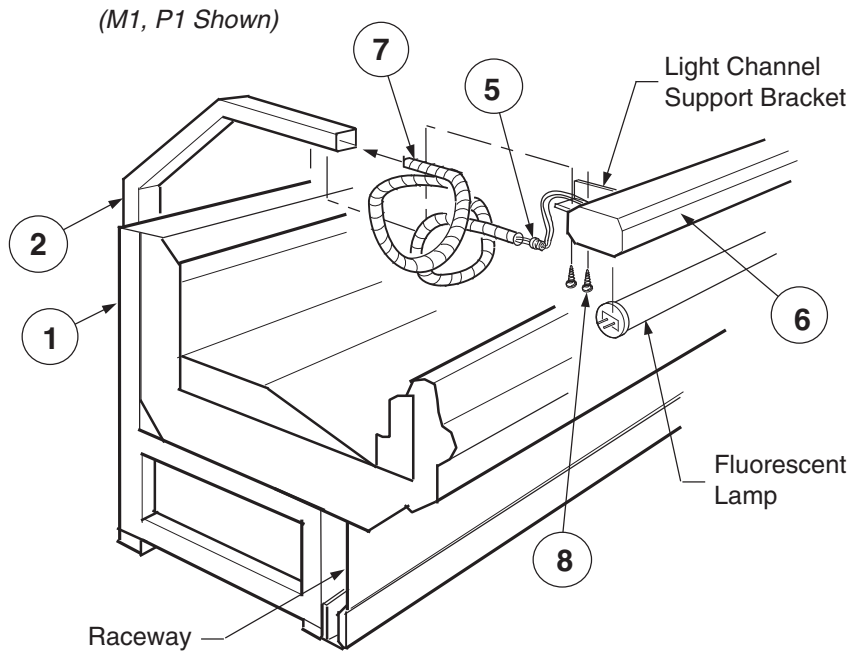

## Installing Light Fixture Assembly

**4** Place **Anti-short Bushing – 5** over wires exiting from left-hand end of **Light Fixture Assembly – 6**.

**5** Insert wires into **Conduit – 7**.  
**A.** Insert Light Channel Support Brackets into top of Tube Assembly while feeding conduit and wires inside left-hand Tube Assembly.  
**B.** Holes in Light Channel Support Brackets should line up with holes in Tube Assembly. Fasten **Light Fixture Assembly – 6** to light bar Tube Assembly using **Screws – 8**.

**C.** Fasten **90° Connector – 9** to one of the knockouts in the raceway.

**D.** Insert the remaining **Anti-short Bushing – 5** over the wires exiting the conduit. Fasten conduit to the connector in the raceway.

**6** Insert Fluorescent Lamp

**NOTE:** These Light bar kits require the following power supply. Fuse accordingly.

8 ft Light Bar 120V/60Hz 0.51A  
 12 ft Light Bar 120V/60Hz 0.77A

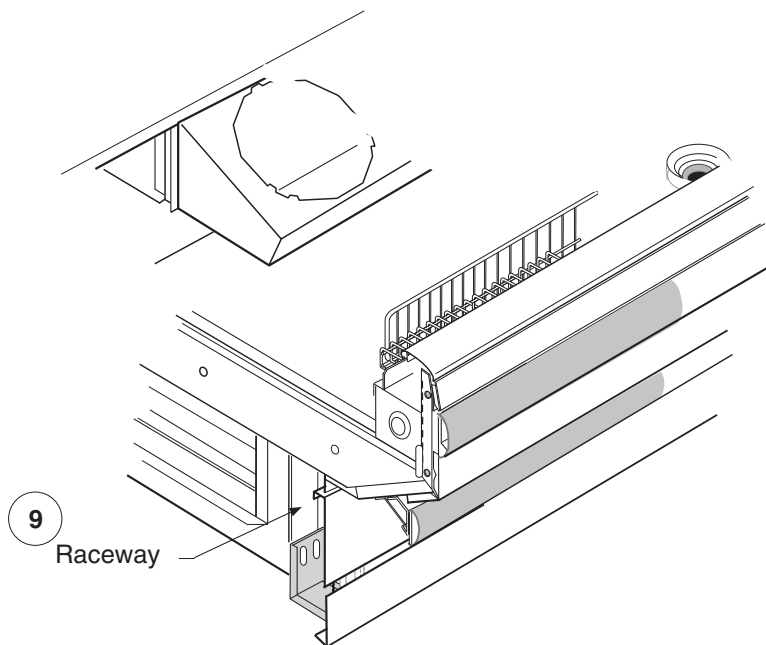

## Installing Light Fixture Assembly

**1-12 REFRIGERATION / ELECTRICAL**

**NOTE:** Each light fixture has a light switch located at the left-hand end behind the fluorescent lamps. Each ballast is attached to a cover plate which is fastened to the underside of the light fixture.

**JOINING LIGHT BARS**

- 7** Mount each light bar assembly to its case.
- 8** Before placing cases in lineup, remove the light fixture's **End Caps** from each of the joining cases. This will expose the **Light Channels**.
- 9** To remove the end caps use a screw driver to take out the four **Snap Rivets**. Discard the end caps.
- 10** Place cases in lineup. Fasten the light channels together by joining the "L" brackets (see Detail) using **Screws -10**, **Flat Washers - 4**, and **Hex Nuts -11**.

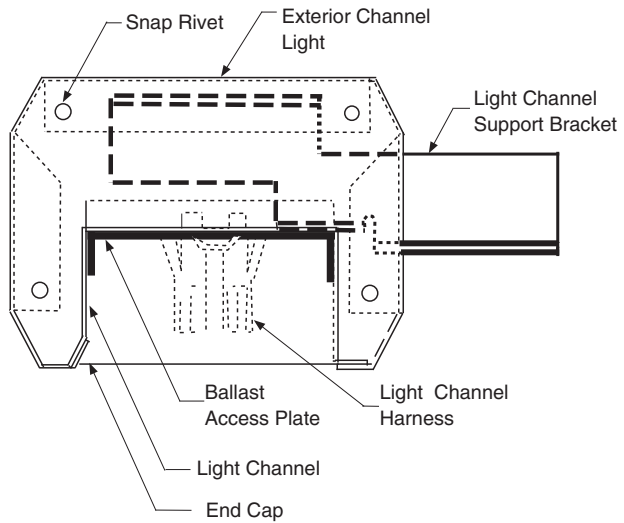
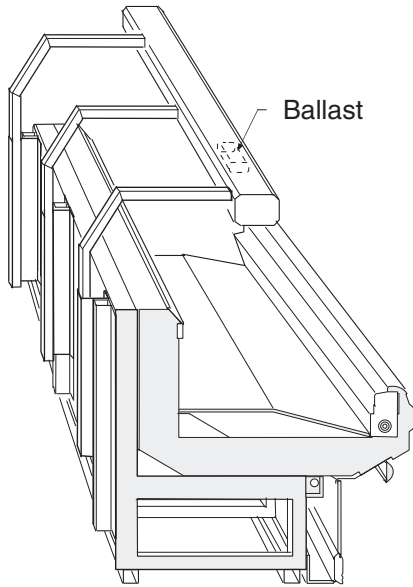

**Light Fixture Assembly**

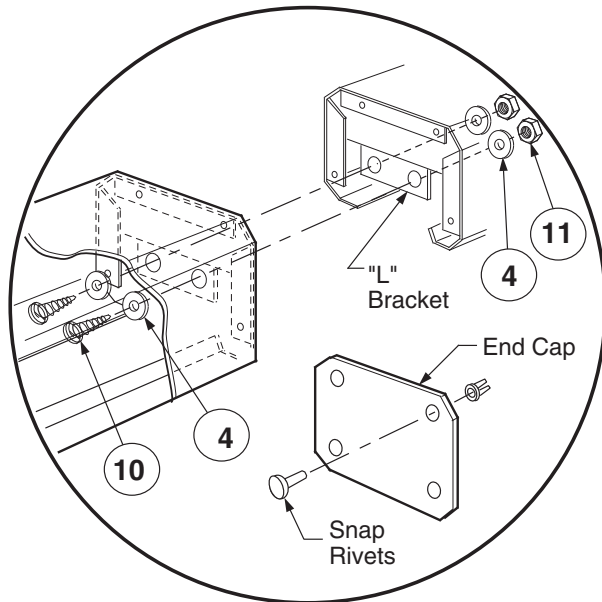

**Detail Joining Light Bars**



# ELECTRICAL / REFRIGERATION

## MERCHANDISER ELECTRICAL DATA

Technical data sheets are shipped with this manual. The data sheets provide merchandiser electrical data, electrical schematics, parts lists and performance data. Refer to the technical data sheets and merchandiser serial plate for electrical information.

**ALWAYS CHECK THE SERIAL PLATE FOR COMPONENT AMPERES**



**It is the contractor's responsibility to install merchandiser(s) in accordance with all local building and health codes.**

**⚠ WARNING**

**— LOCK OUT / TAG OUT —**

*To avoid serious injury or death from electrical shock, always disconnect the electrical power at the main disconnect when servicing or replacing any electrical component. This includes, but is not limited to, such items as doors, lights, fans, heaters, and thermostats.*

### WIRING COLOR CODE

Leads for all electrical circuits are identified by a colored plastic band: neutral wire for each circuit has either White insulation or a White plastic sleeve in addition to the color band.

- |              |                               |  |                      |
|--------------|-------------------------------|--|----------------------|
| PINK .....   | REFRIG. THERMOSTAT LOW TEMP.  | ORANGE OR                                    |                      |
| LIGHT BLUE.. | REFRIG. THERMOSTAT NORM TEMP. | TAN .....                                    | LIGHTS               |
| DARK BLUE .. | DEFROST TERM. THERMOSTAT      | MAROON...                                    | RECEPTACLES          |
| PURPLE.....  | CONDENSATE HEATERS            | YELLOW....                                   | DEFROST HEATERS 120V |
| BROWN .....  | FAN MOTORS                    | RED .....                                    | DEFROST HEATERS 208V |
| GREEN* ..... | GROUND                        | *EITHER COLORED SLEEVE OR COLORED INSULATION |                      |

**ELECTRICIAN NOTE: Use copper conductor wire only.  
MERCHANTISER MUST BE GROUNDED**

**THESE ARE MARKER COLORS. WIRES MAY VARY.**

## 2-2 REFRIGERATION / ELECTRICAL

### Power Cord

The power cord is attached inside the handy box. Verify that the electrical outlet is intended for the plug.

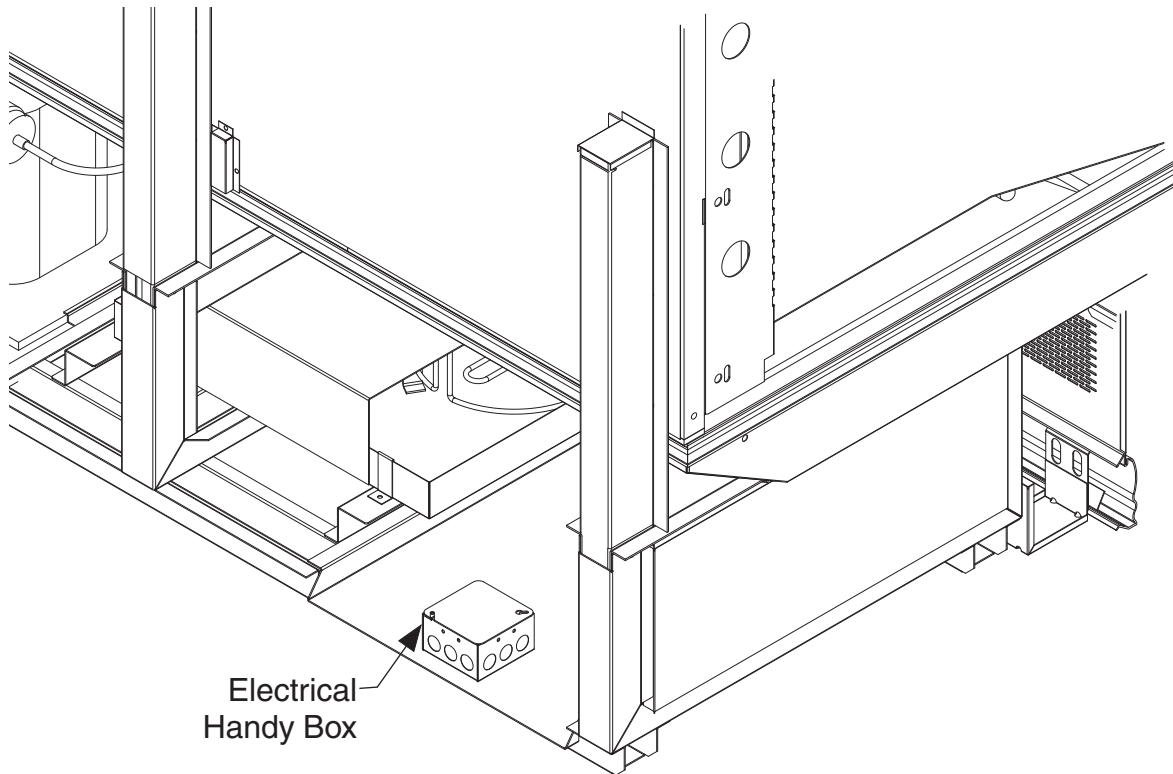

**Electrical Outlet:**

Before the merchandiser is connected to any wall circuit, use a voltmeter to check that the outlet is at 100% of the rated voltage. The wall circuit must be dedicated for the merchandiser. Failure to do so voids the warranty. Do not use an extension cord. Never plug in more than one merchandiser per electrical circuit.

**REFRIGERANT**

Each self-contained model is equipped with its own condensing unit and control panel located beneath the display area. The correct type of refrigerant will be stamped on each merchandiser’s serial plate. The merchandiser refrigeration piping is leak tested. The unit is charged with refrigerant, and shipped from the factory with all service valves open. The merchandiser is ready for operation once electrical power is connected.

Refer to the merchandiser serial plate and the merchandiser data sheet shipped with this manual for defrost information and refrigeration control settings.

**REFRIGERATION THERMOSTAT**

Refrigeration temperature is controlled by a refrigeration thermostat factory-installed in the control panel. To access the control panel, remove the lower front panel and front baffle.

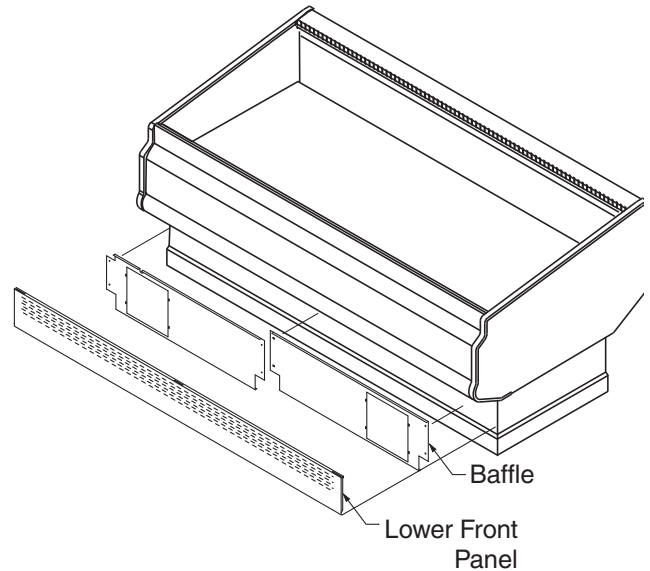

The discharge air temperature is factory set. Check the thermostat for discharge air temperature. Refer to the merchandiser’s serial plate or data sheet to ensure the model’s discharge air temperature is correctly set.

**⚠ WARNING**

**Refrigeration lines are under pressure. Refrigerant must be recovered before attempting any connection or repair.**

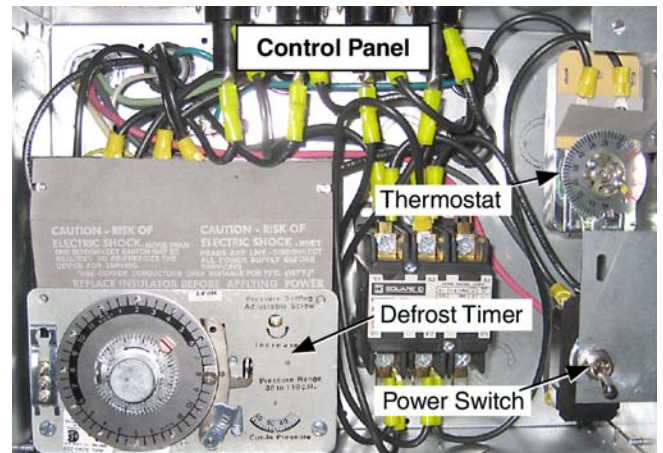

## 2-4 REFRIGERATION / ELECTRICAL

During merchandiser startup, place a temperature probe at the center of the discharge honey-comb or use a thermometer to ensure the merchandiser reaches the proper discharge air temperature.

Do not load merchandiser with product until merchandiser reaches proper discharge air temperature.

### COMPRESSOR

Refer to the compressor's installation manual, which is attached to the compressor. Read and follow all installation procedures. Remove manual, and keep for future reference.



## WARNING

**Product will be degraded and may spoil if allowed to sit in a non-refrigerated area.**

### DEFROST TIME CLOCK OPERATION

These merchandisers require defrost cycles for proper operation. Refer to the data sheets for application data. Defrosts are time-initiated and pressure terminated. The timer senses evaporator pressure, and terminates defrost when the evaporator coil is free of frost. The defrost timer duration is factory set.

All that is required is to set the timer to the correct time of day. The evaporator fans continue to circulate air across the evaporator coil, melting any frost build-up. Defrosts must be terminated by the pressure setting, not by time, to ensure a thorough defrost. It may be necessary to increase the failsafe time in high ambient conditions.

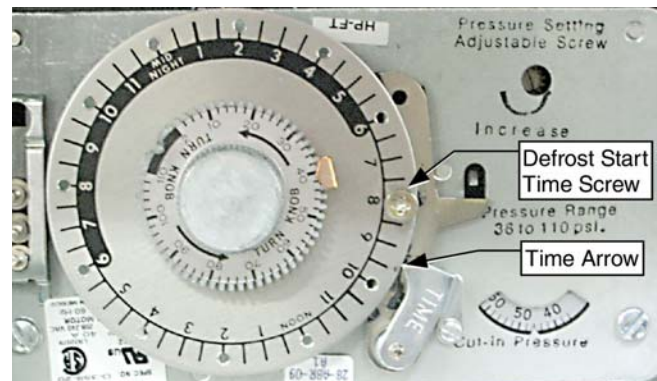

To adjust the defrost clock to the current time of day turn the knob until the appropriate time on the wheel lines up with the time arrow.

**NOTE:** Moving the defrost start time screw to a different location on the defrost wheel changes the start time of defrost. The pressure range settings determine the pressure in which defrost is terminated.

### WASTE OUTLET AND WATER SEAL

The factory installed waste outlet is located in front of the fan plenum. Drainage water will empty from the waste outlet into the evaporator pan.

## START UP / OPERATION

### START UP

See the merchandiser's technical data sheet for refrigeration settings and defrost requirements. Bring merchandisers down to the operating temperatures listed on the data sheet.

Each self-contained merchandiser has its own evaporator coil and a pre-set thermostatic expansion valve (TEV). No adjustment is required.

The TEV has been factory set at design conditions to provide the recommended performance settings as specified on the merchandiser data sheets.

The crankcase pressure regulating (CPR) refrigeration valve is factory set and requires no adjustment.

### LOAD LIMITS

Each merchandiser has a load limit decal. Shelf life of perishables will be short if load limit is violated.



**AT NO TIME SHOULD MERCHANDISERS BE STOCKED BEYOND THE LOAD LIMITS INDICATED.**

### DO NOT BLOCK HONEYCOMB.

### STOCKING

Product should NOT be placed inside the merchandisers until merchandisers are at proper operating temperature.

Proper rotation of product during stocking is necessary to prevent product loss. Always bring the oldest product to the front and set the newest to the back.

**AIR DISCHARGE AND RETURN FLUES MUST REMAIN OPEN AND FREE OF OBSTRUCTION AT ALL TIMES** to provide proper refrigeration and air curtain performance. Do not allow product, packages, signs, etc. to block these grilles. Do not use non-approved shelving, baskets, display racks, or any accessory that could hamper air curtain performance.

Do not allow product to be placed outside of the designated load limits in the illustration below and on the next page.

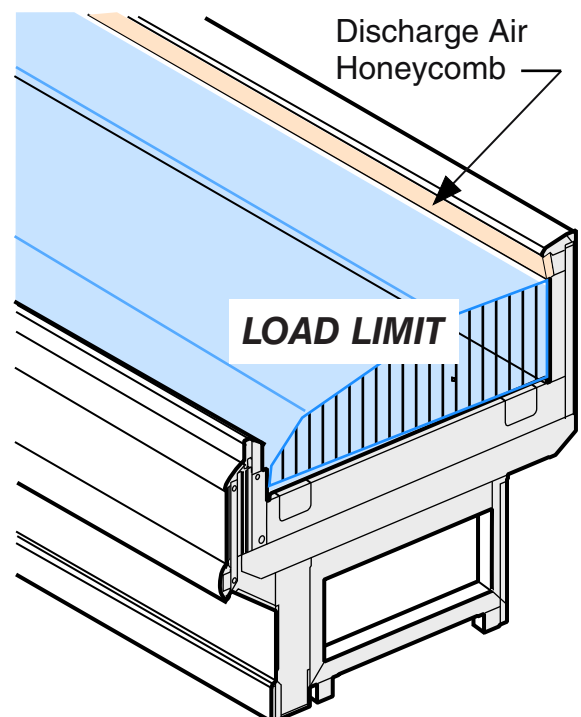

## **3-2            STARTUP & OPERATION**

### **INSTALLING FDA/NSF REQUIRED THERMOMETER**

The following pages provide the same information that ships with the thermometer.

Please note that the tape cannot be exposed after installation.

# This is an NSF-7 & US FDA Food Code Required Thermometer

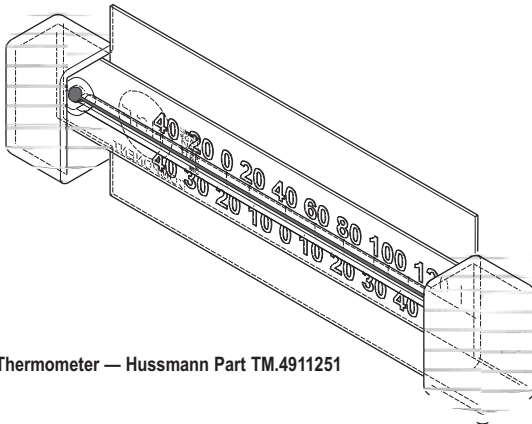

Thermometer — Hussmann Part TM.4911251

Hussmann Corporation • 12999 St. Charles Rock Road • Bridgeton, MO 63044-2483  
U.S. & Canada 1-800-922-1919 • Mexico 1-800-522-1900 • www.hussmann.com  
© 2007 Hussmann Corporation

## Suggested Mounting Locations in Single Deck Glass Front Impact Merchandisers

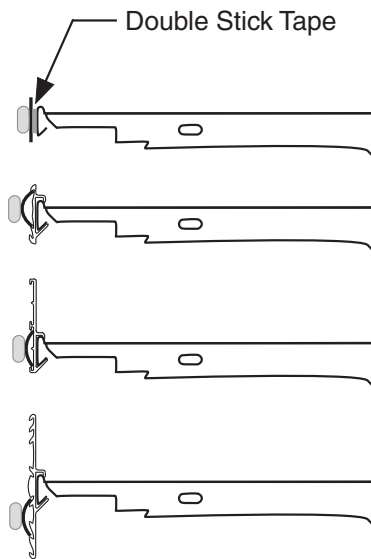
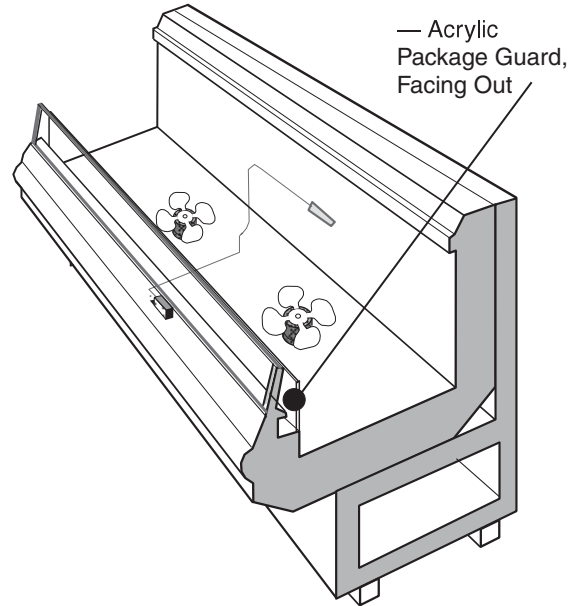

Flexible Plastic Fits in Price Tag Moldings

Hussmann P/N 0429971\_C

10/2007

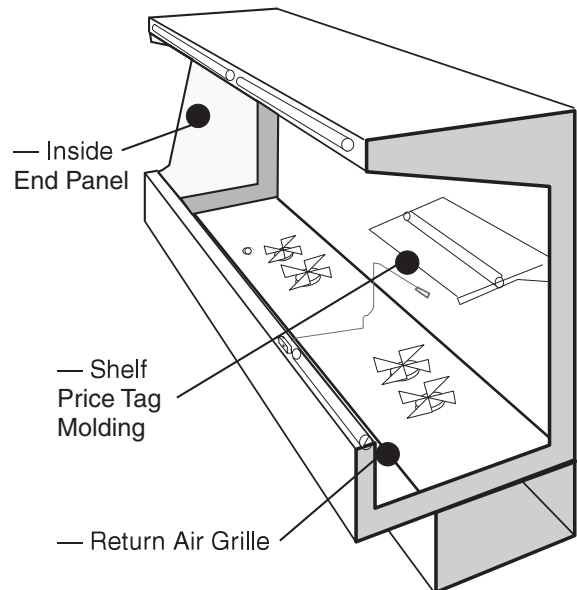

## Suggested Mounting Locations in Multi-deck Merchandisers

# Important – Please read!

---

This thermometer is provided in response to United States  
Food and Drug Administration (US FDA) Food Code [ <http://www.fda.gov/> ]  
and  
National Sanitation Foundation (NSF / ANSI) Standard 7 [ <http://www.nsf.org/> ]

---

Each installation will be different depending on how the unit is stocked, shopping patterns in the department and ambient conditions of the store. The suggested locations provided herein are possible locations. It is the responsibility of the purchaser / user to determine the location within the food storage area of the unit that best meets the code requirements above.

The thermometer may need to be moved several times to find the warmest location. Mounting options include flexible plastic for price tag molding application, magnet applied to back of flexible plastic for steel end wall, and double stick tape. Tape must not be exposed after installation.

Questions about either code should be addressed to local agencies or other appropriate officials.

---

**Keep with merchandiser**

**or give to store manager.**

**DO NOT DESTROY.**



## MAINTENANCE

### CARE AND CLEANING

Long life and satisfactory performance of any equipment is dependent upon the care it receives. To ensure long life, proper sanitation and minimum maintenance costs, these merchandisers should be thoroughly cleaned, all debris removed and the interiors washed down, weekly.

#### Exterior Surfaces

The exterior surfaces must be cleaned with a mild detergent and warm water to protect and maintain their attractive finish. **NEVER USE ABRASIVE CLEANSERS OR SCOURING PADS.**

#### Interior Surfaces

The interior surfaces may be cleaned with most domestic detergents, ammonia based cleaners and sanitizing solutions with no harm to the surface.

#### **Do NOT Use:**

- Abrasive cleansers and scouring pads, as these will mar the finish.
- Coarse paper towels on coated glass.
- Ammonia-based cleaners on acrylic parts.
- A hose on any electrical connection, or submerge them in water.
- Solvent, oil or acidic based cleaners on any interior surfaces.
- Do not use high pressure water hoses.

#### **Do:**

- **Disconnect electrical power before cleaning.**
- Remove the product and all loose debris to avoid clogging the waste outlet.
- Store product in a refrigerated area such as a cooler. Remove only as much product as can be taken to the cooler in a timely manner.
- Thoroughly clean all surfaces with soap and hot water. **DO NOT USE STEAM OR HIGH WATER PRESSURE HOSES TO WASH THE INTERIOR. THESE WILL DESTROY THE MERCHANDISERS' SEALING CAUSING LEAKS AND POOR PERFORMANCE.**
- Lift hinged fan plenum for cleaning. Hook chain in rear panel to secure plenum during cleaning. **BE SURE TO REPOSITION THE FAN PLENUM AFTER CLEANING MERCHANDISER.**
- Take care to minimize direct contact between fan motors and cleaning or rinse water.
- Do NOT flood merchandiser with water. **NEVER INTRODUCE WATER FASTER THAN THE WASTE OUTLET AND DRAIN TUBE CAN REMOVE IT. WATER FROM EVAPORATOR PAN WILL OVERFLOW ONTO THE FLOOR.**
- Allow merchandisers to dry before resuming operation.
- After cleaning is completed, turn on power to the merchandiser.



### WARNING

**Do NOT allow cleaning agent or cloth to contact food product.**



### WARNING

Product will be degraded and may spoil if allowed to sit in a non-refrigerated area.



## WARNING

**SHUT FANS OFF DURING  
CLEANING PROCESS.**

### Cleaning Front Shelf Support and Return Air Grille

The front shelf support may be removed to facilitate cleaning. Simply lift a four foot section up and out as shown below.

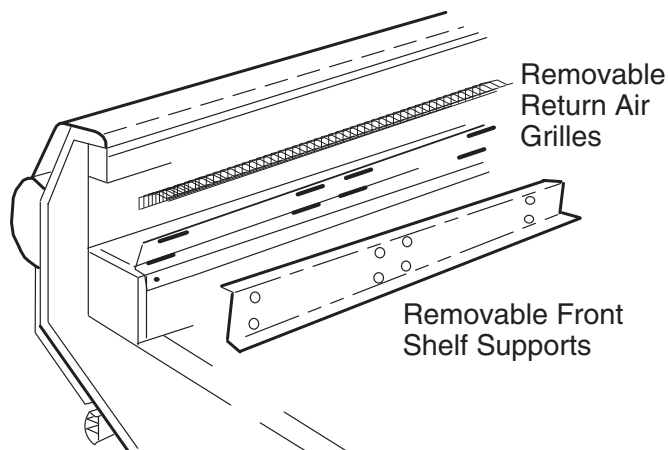

### CLEANING UNDER FAN PLENUM

To facilitate cleaning, the fan plenum is hinged. Raise the fan plenum and use the attached hook to prop the plenum up to the back panel. After cleaning be sure the plenum is properly lowered into position OR PRODUCT LOSS WILL RESULT due to improper refrigeration.

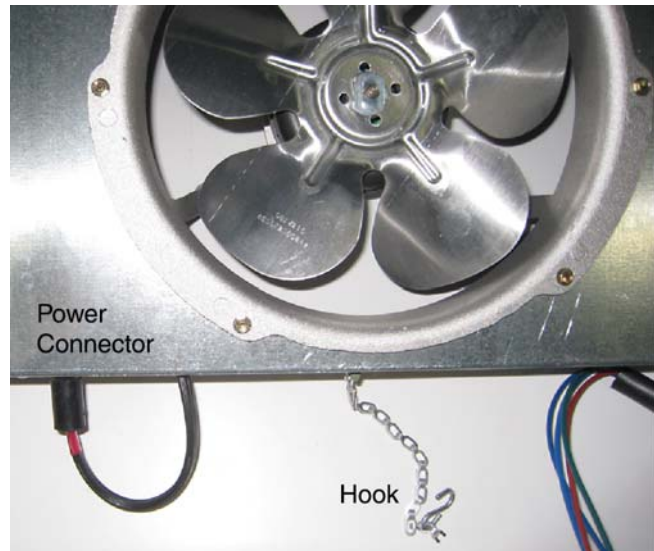

## CAUTION

### DO NOT FLOOD!

**Use only enough water necessary to clean surface. Water must not drip down the case!**

**Never use ammonia based cleansers, abrasive cleansers, or scouring pads.**



## WARNING

**Do NOT use HOT water on Cold glass Surfaces. This can cause the glass to shatter and could result in personal injury. Allow glass fronts, to warm before applying hot water.**

### CLEANING HONEYCOMB ASSEMBLIES

Honeycombs should be cleaned every six months. Dirty honeycombs will cause merchandisers to perform poorly. The honeycombs may be cleaned with a vacuum cleaner. Soap and water may be used if all water is removed from the honeycomb cells before replacing. Be careful not to damage the honeycombs.

1. Using a flat object such as a screw driver, compress the honeycomb and remove it from its retainer.
2. Clean and dry the honeycomb.
3. After cleaning, replace in reverse order.

Damaged honeycomb must be replaced.

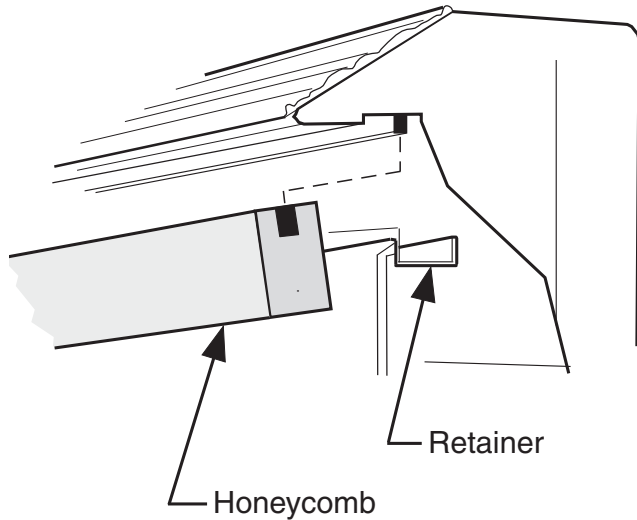

**REMOVING INTERIOR BACK PANELS**

The interior back panels may be removed for cleaning and to gain access to the evaporator coils. Remove the rear interior back panels as follows:

1. **DISCONNECT THE ELECTRICAL POWER TO THE MERCHANDISER.**
2. Remove the panel by lifting the panel up, then pull forward and out.
3. Replace panels in reverse order, starting with the top panel.
4. Return power to the merchandiser after cleaning or servicing.

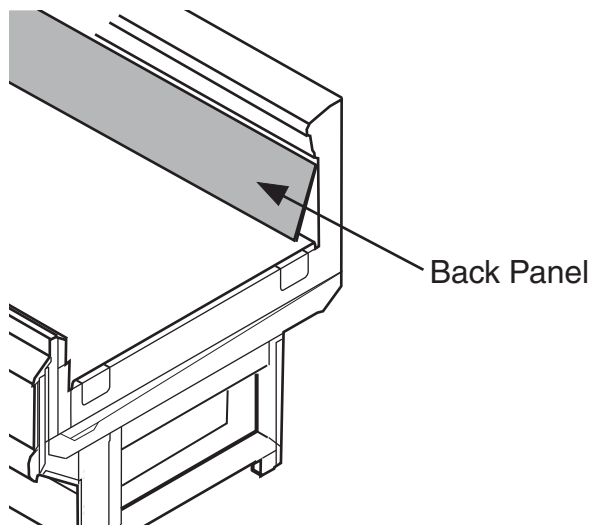

**CLEANING STAINLESS STEEL SURFACES**

Use non-abrasive cleaning materials, and always polish with grain of the steel. Use warm water or add a mild detergent to the water and apply with a cloth. Always wipe rails dry after wetting.

Use alkaline chlorinated or non-chlorine containing cleaners such as window cleaners and mild detergents. Do not use cleaners containing salts as this may cause pitting and rusting of the stainless steel finish. Do not use bleach.

Clean frequently to avoid build-up of hard, stubborn stains. A stainless steel cleaning solution may be used periodically to minimize scratching and remove stains.

Rinse and wipe dry immediately after cleaning. Never use hydrochloric acid (muriatic acid) on stainless steel.

WARNING

— LOCK OUT / TAG OUT —

To avoid serious injury or death from electrical shock, always disconnect the electrical power at the main disconnect when servicing or replacing any electrical component. This includes, but is not limited to, such items as doors, lights, fans, heaters, and thermostats.

CLEANING COILS

NEVER USE SHARP OBJECTS AROUND COILS. Use a soft brush or vacuum brush to clean debris from coils. Do not puncture coils! Do not bend fins. Contact an authorized service technician if a coil is punctured, cracked, or otherwise damaged.

ICE in or on the coil indicates the refrigeration and defrost cycle is not operating properly. Contact an authorized service technician to determine the cause of icing and to make adjustments as necessary. To maintain product integrity, move all product to a cooler until the unit has returned to normal operating temperatures.

**Do NOT use chlorine or ammonia-based cleaners to clean aluminum coils.**

Condenser coils should be cleaned at least once per month. Additional cleaning may be needed depending on the operational environment. A dirty condenser blocks normal airflow through the coils. Airflow blockage increases energy consumption and reduces the merchandiser's ability to maintain operating temperature.

To clean the coils, use a vacuum cleaner with a wand attachment and a soft (non-metallic) brush to remove dirt and debris. Do not bend coil fins. Always wear gloves and protective eye wear when cleaning near sharp coil fins and dust particles.

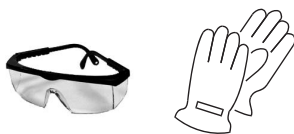

CLEANING EVAPORATOR PAN

 <b>CAUTION</b>
<p><b>Evaporator Pan is Hot!</b> and poses risk of bodily injury – Always Wear gloves and protective eye wear when servicing. Turn off evaporator pan heater, and allow pan to cool.</p>

The waste outlet for self-contained models empties into a limited capacity evaporator pan. Water introduced during cleaning will cause the evaporator pan to overflow. Therefore, the evaporator pan is equipped with a side outlet drain tube.

Access to the drain tube is through the back panel. During cleaning, remove the drain tube from its retainer on the evaporator pan, and connect the tube to a remote hose that will carry water away from the merchandiser to a floor drain.

Once cleaning is complete and the evaporator pan and drain tube are empty, separate the drain tube from the hose, fold the drain tube over itself and return the tube to its retainer.

Remove accumulated debris from the evaporator pan. Wipe down heater coil with a cloth and warm water. Be sure to remove any dirt, debris or liquids from the heater coil.

Debris or dirt accumulation inside the condensate evaporator pan or on the heater coil will reduce the pan's evaporation capacity and cause premature heater failure. The evaporator pan waste water will overflow and spill onto the floor if the heater is not properly operating.

Refer to the illustrations on the next page.

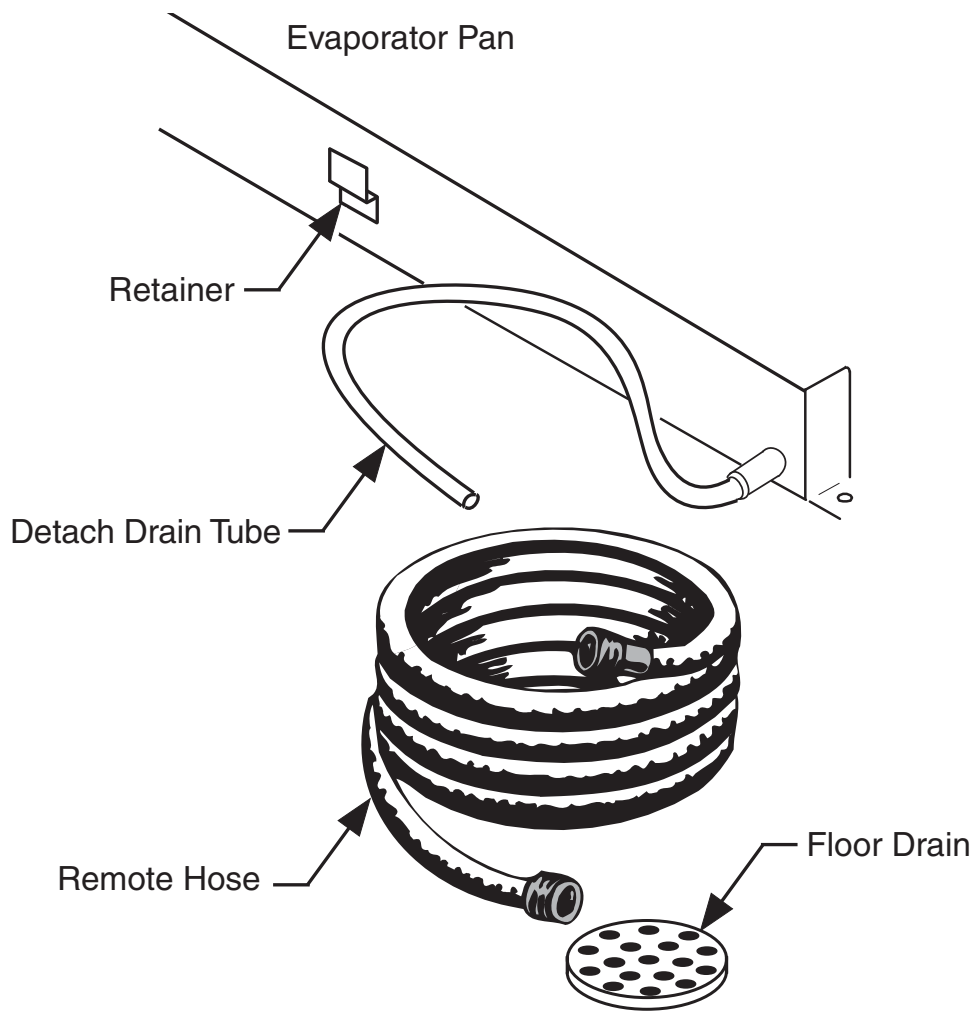
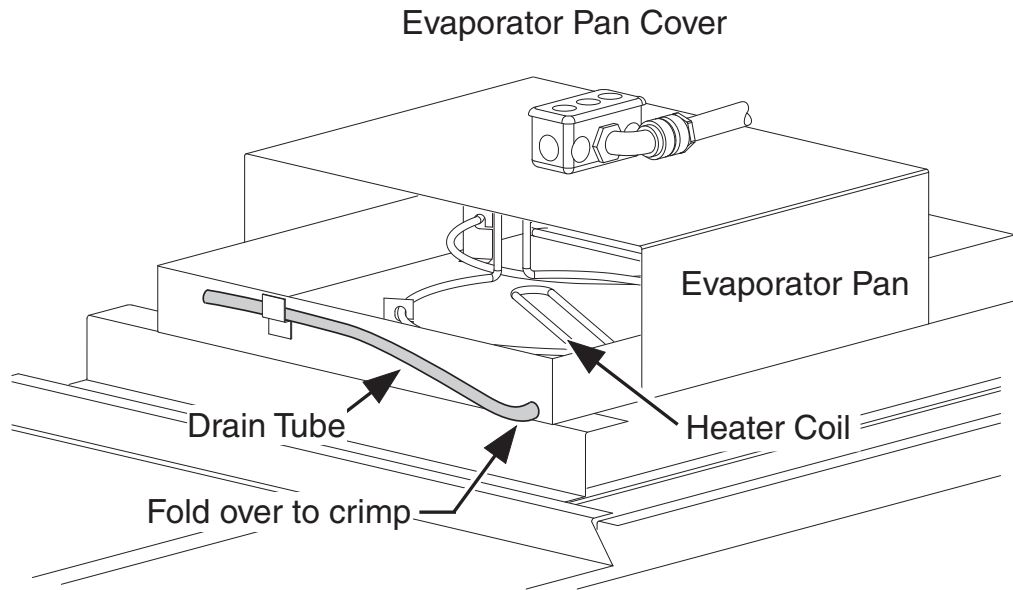

**CLEANING UNDER MERCHANDISERS**

Remove splashguards not sealed to floor. Use a vacuum with a long wand attachment to remove accumulated dust and debris from under the merchandiser.

**REMOVING SCRATCHES FROM BUMPER**

Most scratches and dings can be removed using the following procedure.

1. Use steel wool to smooth out the surface area of the bumper.
2. Clean area.
3. Apply vinyl or car wax and polish surface for a smooth glossy finish.

## SERVICE

## REPLACING FAN MOTORS AND BLADES

See cross section drawing on technical data sheets for location of evaporator fans. Should it ever be necessary to service or replace the fan motors or blades be certain that the fan blades are reinstalled correctly. **THE BLADES MUST BE INSTALLED WITH RAISED EMBOSSED (PART NUMBER ON PLASTIC BLADES) POSITIONED AS INDICATED ON THE PARTS LIST.** (Refer to the merchandiser technical data sheet for each model.)

**For access to these fans:**

1. Remove product and place in a refrigerated area. Turn off power to the merchandiser.
2. Remove bottom display pans.
3. **Disconnect fan from wiring harness.**
4. Remove fan blade.
5. Lift fan plenum and remove screws holding bottom of motor to fan basket.
6. Replace fan motor and blade.
7. Lower fan plenum.
8. Reconnect fan to wiring harness.
9. Turn on power.
10. Verify that motor is working and blade is turning in the correct direction.

**WARNING**

**Product will be degraded and may spoil if allowed to sit in a non-refrigerated area.**

**WARNING****— LOCK OUT / TAG OUT —**

***To avoid serious injury or death from electrical shock, always disconnect the electrical power at the main disconnect when servicing or replacing any electrical component. This includes, but is not limited to, such items as doors, lights, fans, heaters, and thermostats.***

11. Close air gaps under fan plenum. Warmer air moving into refrigerated air reduces effective cooling. If the plenum does not rest against the case bottom without gaps, apply foam tape to the bottom of the fan plenum to reduce improper air movement. Use silicone sealant to close other gaps.
12. Reinstall display pans. Bring merchandiser to operating temperature before restocking.

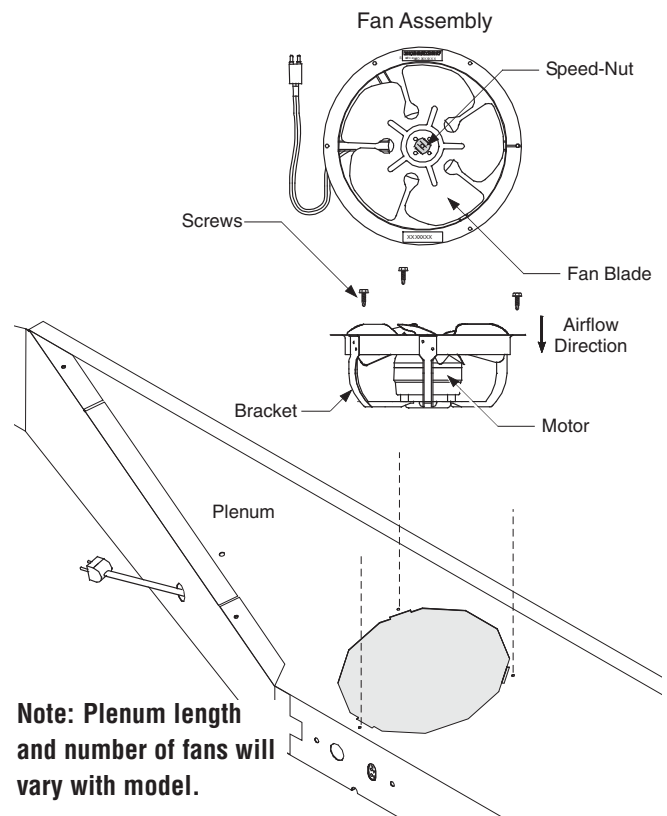

## REPLACING NOSING ANTI-SWEAT HEATER (Not All Models)

To replace the heater:

1. Remove product and place in a refrigerated area. Turn off power to the merchandiser.
2. Remove the interior panels from under the nosing heater to be replaced by lifting them up and out.
3. Remove interior panel support bracket.
4. Remove existing screws from sheet metal nosing panel; remove panel.
5. Remove insulation.
6. Unplug and remove existing anti-sweat heater taped to sheet metal nosing panel. In most applications anti-sweat heater plug is routed on left-hand side from front of merchandiser.
7. Tape anti-sweat heater as shown in the illustrations. Route plug to jumper harness. If price tag molding is installed, allow clearance between screws and wiring. Make sure that the edge of foil tape is seated properly. Failure to do so will cause damage to the wiring and heater.

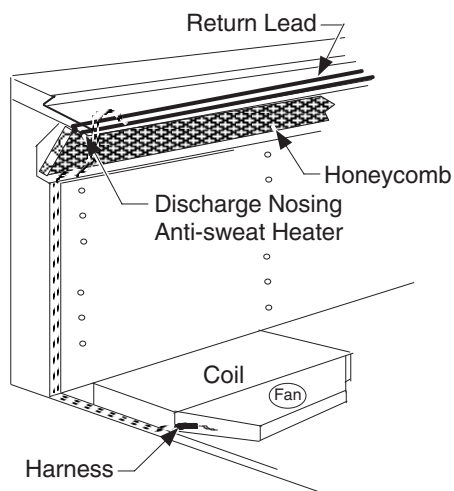

# ⚠ WARNING

— **LOCK OUT / TAG OUT** —

***To avoid serious injury or death from electrical shock, always disconnect the electrical power at the main disconnect when servicing or replacing any electrical component. This includes, but is not limited to, such items as doors, lights, fans, heaters, and thermostats.***

8. Reinstall insulation, sheet metal nosing panel screws, interior panel support bracket and interior panels.
9. Turn on power to merchandiser and check for proper operation.
10. Bring merchandiser to operating temperature before restocking.

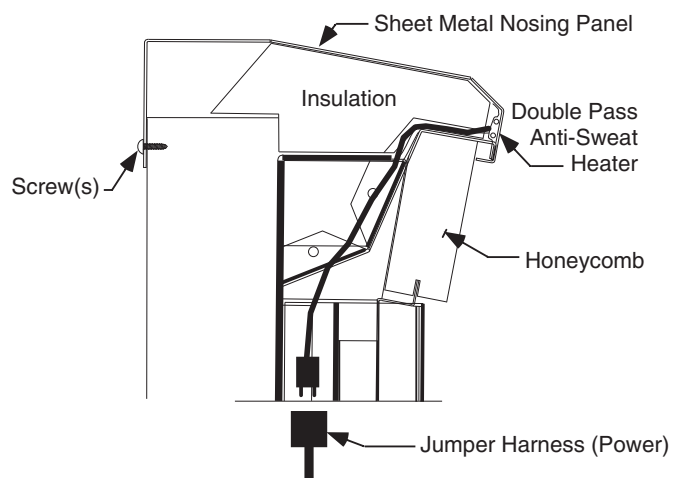
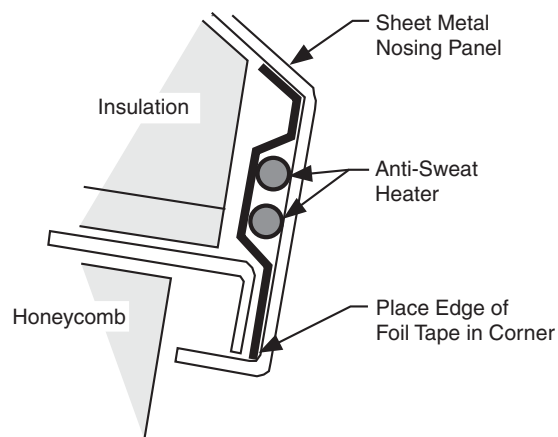



**REPLACING FLUORESCENT LAMPS**

Fluorescent lamps are furnished with moisture resistant lamp holders, shields and end caps. Whenever a fluorescent lamp is replaced, be certain to reinstall the lamp shields and end caps.

The switch in the canopy operates both the canopy and the shelf lamps. The rail lamp switch is located on the rail.

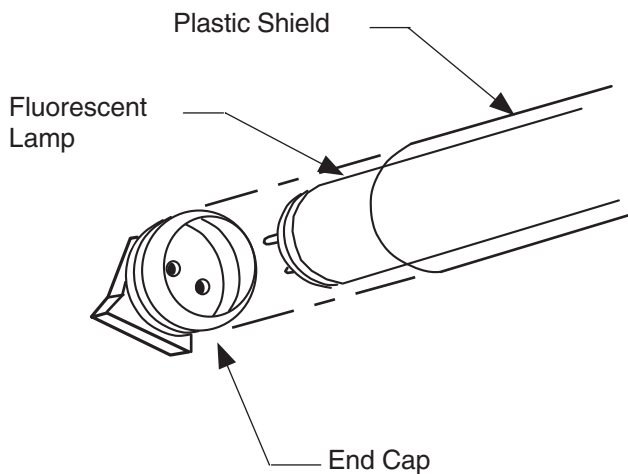

**⚠ WARNING**

**— LOCK OUT / TAG OUT —**

*To avoid serious injury or death from electrical shock, always disconnect the electrical power at the main disconnect when servicing or replacing any electrical component. This includes, but is not limited to, such items as doors, lights, fans, heaters, and thermostats.*

**REPLACING LAMP HOLDERS AND END CAPS**

The lamp holder is designed to snap into the sheet metal of the case. The lamp holder has a locking 'nub' which fits inside the groove of specially designed end caps.

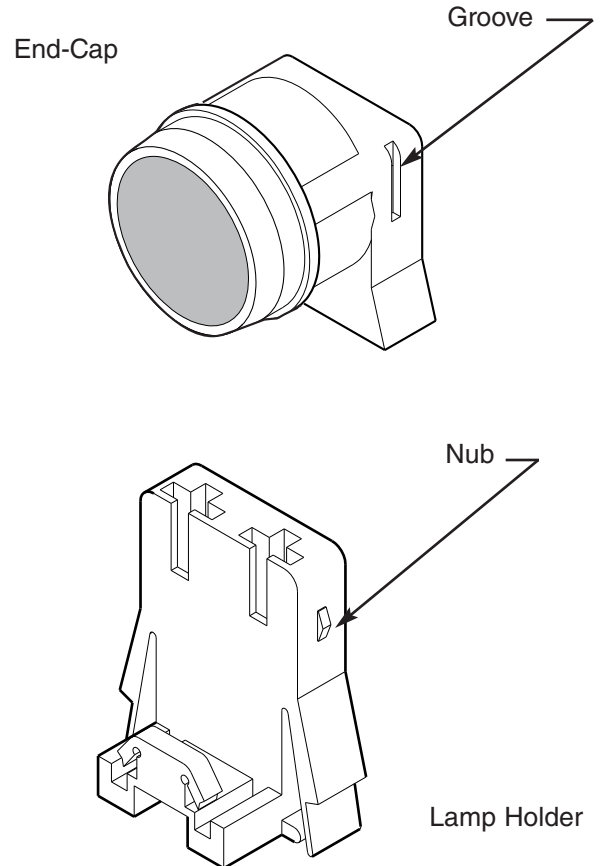

**IMPORTANT!**

Always replace lamp holders and end caps with Hussmann lamp holders and end caps.

Use of non-Hussmann parts may result in poor electrical contact and short lamp life.

### FRONT GLASS ADJUSTMENT

The (optional) front glass panel may be adjusted from side to side by following these steps:

1. Lift out return air grilles and shelf supports.
2. Loosen but do not remove nuts in retainer. There are four nuts in each 4 ft section of glass.
3. Move glass panels horizontally as needed.
4. Tighten nuts enough to hold glass. Do not over-tighten, which will crack or break glass.
5. Replace shelf supports and return air grilles.

 <b>CAUTION</b>
Do not over-tighten nuts. Excess pressure will cause glass to break.

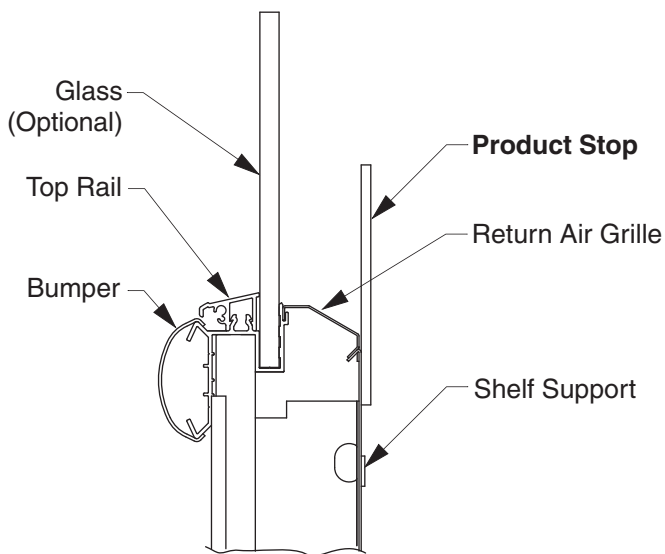

### REPLACING ELECTRONIC BALLASTS

#### Rail Lamp Ballast

The rail lamp ballast is located in the wireway, behind the lower front panel at the left-hand end of the merchandiser.

**NOTE:** The rail lamp switch is located on the rail.

#### To gain access:

1. **DISCONNECT THE ELECTRICAL POWER TO THE MERCHANDISER.**
2. Remove the lower front panel by lifting it up and out.
3. Remove screws attaching the wireway cover, then remove cover.
4. Service or replace ballast as required. Reassemble items as they were originally installed.
5. Reconnect the electrical power.

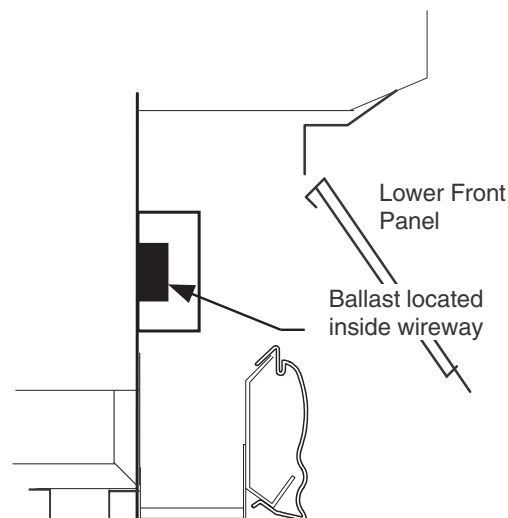

## REPLACING DAMAGED DRAIN FITTING

The following procedure is for the field repair of a broken drain fitting.

1. Use a drill with a 2 in. (51 mm) hole saw to drill out the bottom of the drain fitting. Be sure to drill completely through fitting and bottom liner.

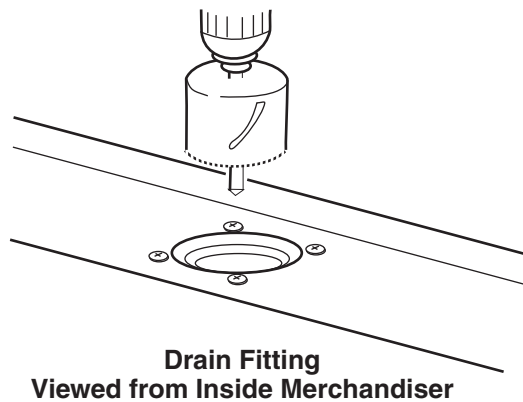

2. Apply an ABS and PVC compatible primer-sealer to outside of PVC coupling and inside of drain. Insert coupling into drain fitting.
3. Install a PVC adapter on the drip trap. Apply primer-sealer to a stub piece of PVC pipe and insert between coupling and adapter.

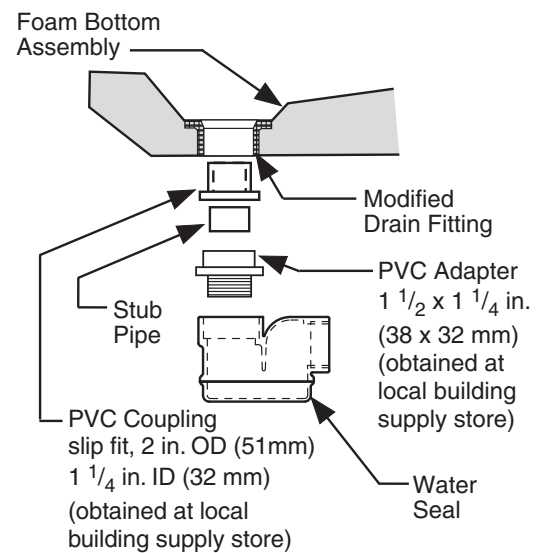

**REPAIRING ALUMINUM COIL**

The aluminum coils used in Hussmann merchandisers may be easily repaired in the field. Materials are available from local refrigeration wholesalers.

Hussmann recommends the following solders and technique:

**Solders****Aladdin Welding Products Inc.**

P.O. Box 7188  
1300 Burton St.  
Grand Rapids, MI 49507  
Phone: 1-800-645-3413  
Fax: 1-800-645-3414

**X-Ergon**

1570 E. Northgate  
P.O. Box 2102  
Irving, TX 75062  
Phone: 1-800-527-9916

**NOTE:**

Hussmann Aluminum melts at 1125°F (607°C)  
Aladdin 3-in-1 rod at 732°F (389°C)  
X-Ergon Acid core at 455°F (235°C)

**Technique:**

1. Locate Leak.
2. REMOVE ALL PRESSURE.
3. Brush area UNDER HEAT.
4. Use PRESTOLITE TORCH ONLY. Number 6 tip.
5. Maintain separate set of stainless steel brushes and USE ONLY ON ALUMINUM.
6. Tin surface around area.
7. Brush tinned surface UNDER HEAT, thoroughly filling the open pores around leak.
8. Repair leak. Let aluminum melt solder, NOT the torch.
9. Don't repair for looks. Go for thickness.
10. Perform a leak check.
11. Wash with water.
12. Cover with a good flexible sealant.

# **HUSSMANN<sup>®</sup>**

To obtain warranty information  
or other support, contact your Hussmann  
representative.

Please include the model and  
serial number of the product.

**Husmann Corporation**

12999 St. Charles Rock Road

Bridgeton, MO 63044-2483

[www.husmann.com](http://www.husmann.com)