

TOP VIEW AND CLEARANCE REQUIREMENTS ON SHEET 3

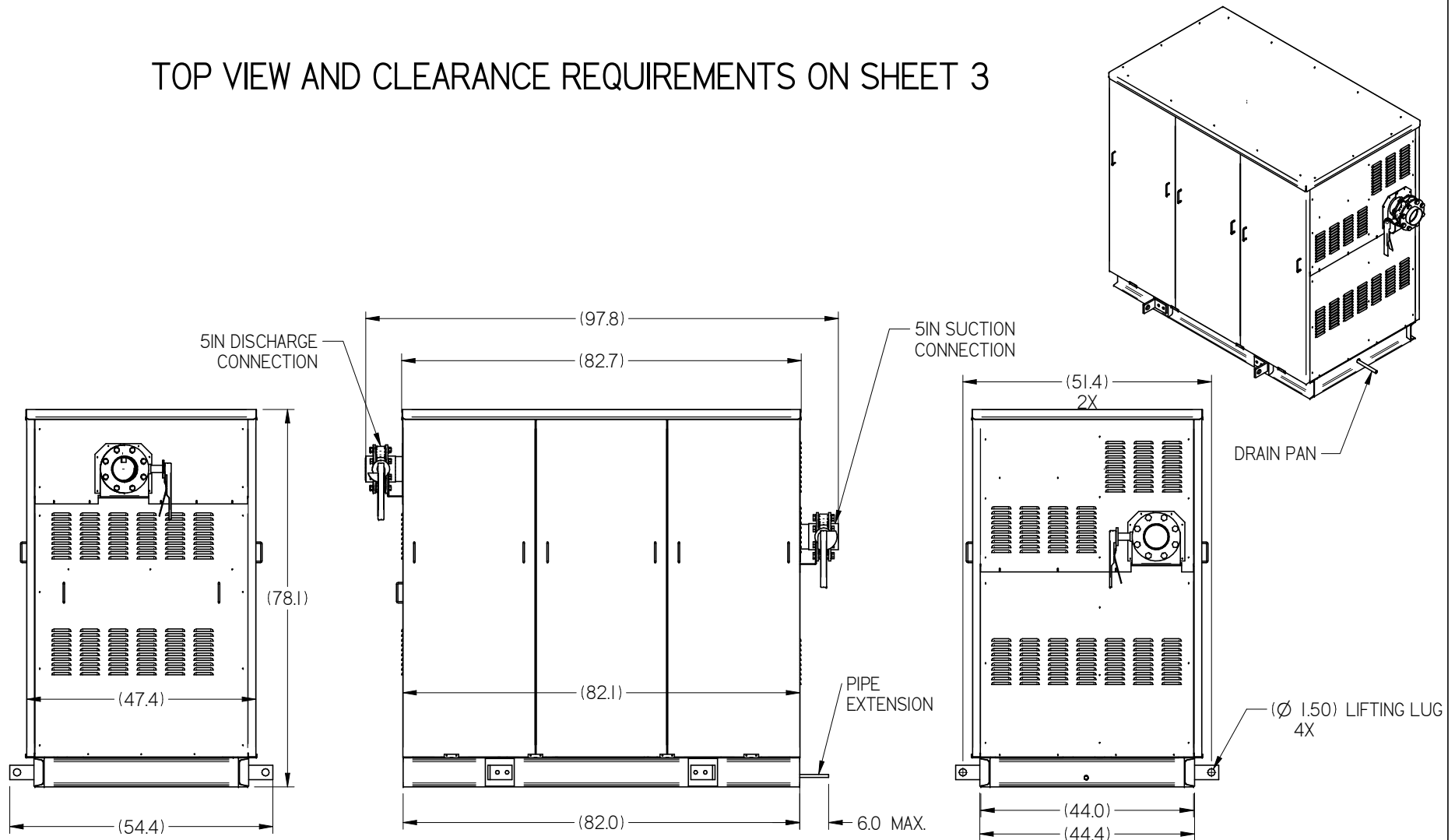

NOTES:

1. IT IS THE RESPONSIBILITY OF THE INSTALLING CONTRACTOR TO ENSURE THAT THE FINAL EQUIPMENT INSTALLATION MEETS ALL APPLICABLE CODE REQUIREMENTS.
2. ILLUSTRATION SHOWN IS FOR GENERAL REPRESENTATION ONLY. ACTUAL PRODUCT WILL VARY DEPENDENT UPON APPLICATION.
3. OVERALL DIMENSIONS: 97.8 L X 54.4 W X 78.1 H.

DIMENSIONS ARE IN INCHES.
DATE DRAWN: 2017/09/15



HUSSMANN®

PUMP STATION-5IN
OUTDOOR FRAME
AND SKINS

DOC PD-000000090 REV B

INFORMATION SUBJECT TO CHANGE

SHEET 1 OF 3

5IN10 SUBMITTAL SHEET SIZE D

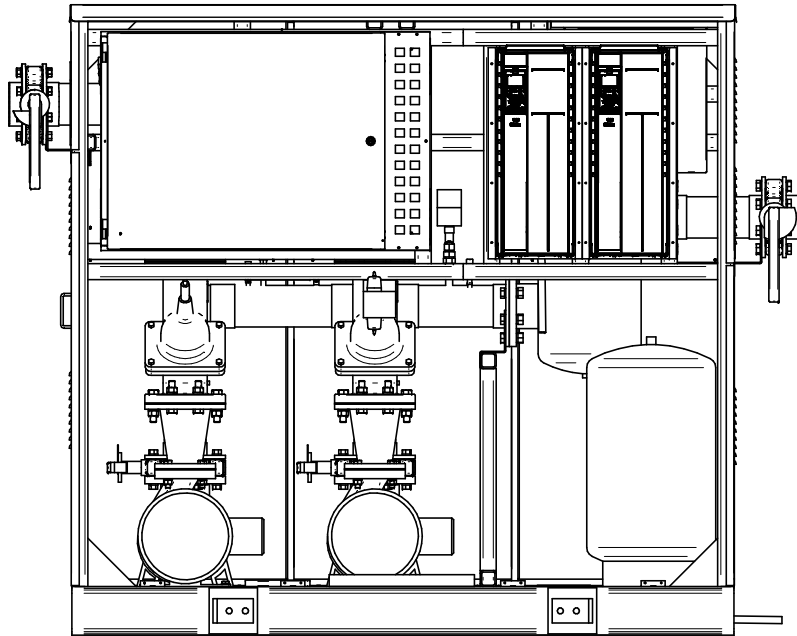

FRONT VIEW WITHOUT DOORS
 ARMSTRONG PUMPS CONFIGURATION SHOWN,
 B & G IS DIFFERENT

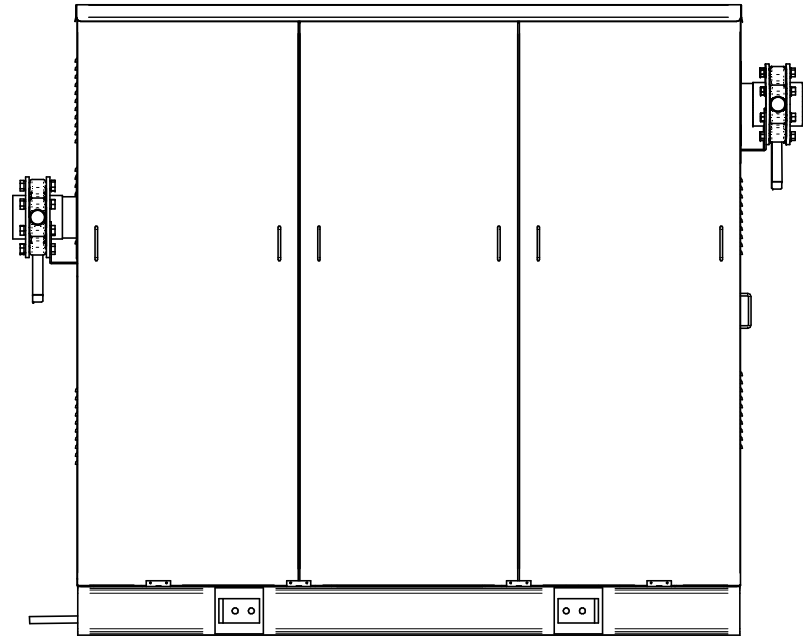

BACK VIEW

NOTES:

1. IT IS THE RESPONSIBILITY OF THE INSTALLING CONTRACTOR TO ENSURE THAT THE FINAL EQUIPMENT INSTALLATION MEETS ALL APPLICABLE CODE REQUIREMENTS.
2. ILLUSTRATION SHOWN IS FOR GENERAL REPRESENTATION ONLY. ACTUAL PRODUCT WILL VARY DEPENDENT UPON APPLICATION.
3. OVERALL DIMENSIONS: 97.8 L X 54.4 W X 78.1 H.

DIMENSIONS ARE IN INCHES.
 DATE DRAWN: 2017/09/15



THIRD
 ANGLE
 PROJECTION

INFORMATION SUBJECT TO CHANGE

SHEET 2 OF 3

HUSSmann®

PUMP STATION-5IN
 OUTDOOR FRAME
 AND SKINS

DOC PD-000000090 REV B

SWIN10 SUBMITTAL SHEET SIZE D

MINIMUM CLEARANCE REQUIREMENTS:

ACTUAL CLEARANCE REQUIREMENTS ARE DEPENDENT UPON AUTHORITY HAVING JURISDICTION, AND MAY EXCEED DIMENSIONS SHOWN.

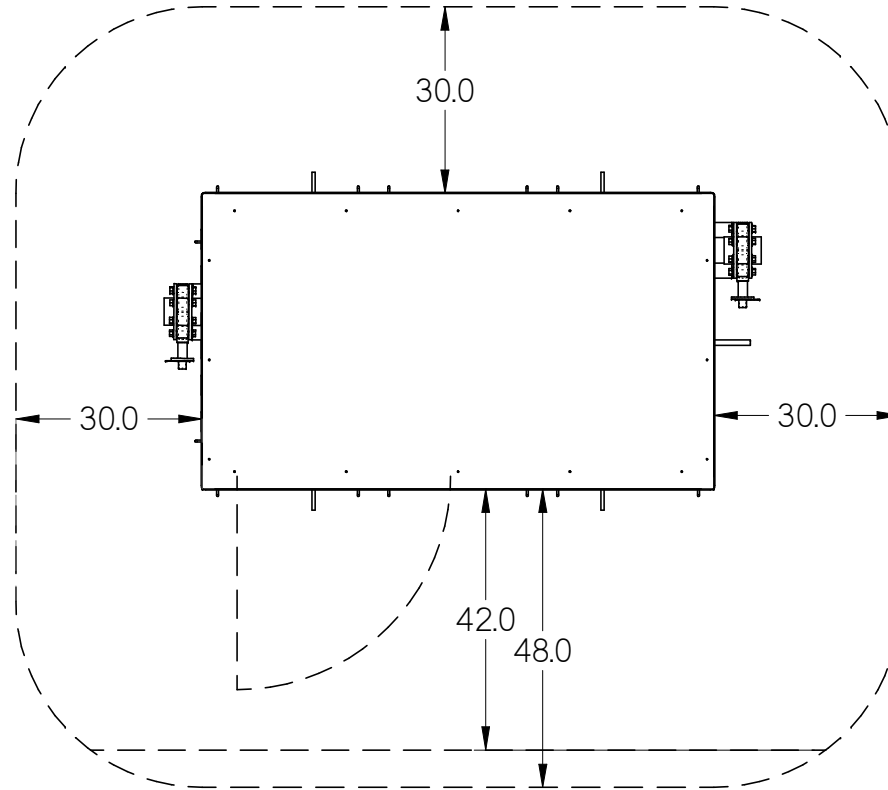

42" CLEARANCE BETWEEN CONTROL PANEL & ANY WALL.

48" CLEARANCE BETWEEN CONTROL PANEL & ANY LIVE PANEL.

NOTES:

1. IT IS THE RESPONSIBILITY OF THE INSTALLING CONTRACTOR TO ENSURE THAT THE FINAL EQUIPMENT INSTALLATION MEETS ALL APPLICABLE CODE REQUIREMENTS.
2. ILLUSTRATION SHOWN IS FOR GENERAL REPRESENTATION ONLY. ACTUAL PRODUCT WILL VARY DEPENDENT UPON APPLICATION.
3. OVERALL DIMENSIONS: 97.8 L X 54.4 W X 78.1 H.

DIMENSIONS ARE IN INCHES.
DATE DRAWN: 2017/09/15

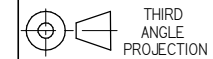

THIRD
ANGLE
PROJECTION

HUSSmann®

PUMP STATION-5IN
OUTDOOR FRAME
AND SKINS

DOC PD-000000090 REV B

INFORMATION SUBJECT TO CHANGE

SHEET 3 OF 3

SWIN10 SUBMITTAL SHEET SIZE D