

GPM (Armstrong)	Motor HP	Weight, Lbs. (operating)	Voltage	MCA (Min. Circuit Ampacity)	MOPD (Max. Overcurrent Protection)
400	15	3750 / 3300	208/230	58	100
			460	27	40
			575	22	35
450	20	4000 / 3550	208/230	75	125
			460	34	60
			575	28	40

TOP VIEW AND CLEARANCE REQUIREMENTS ON SHEET 3

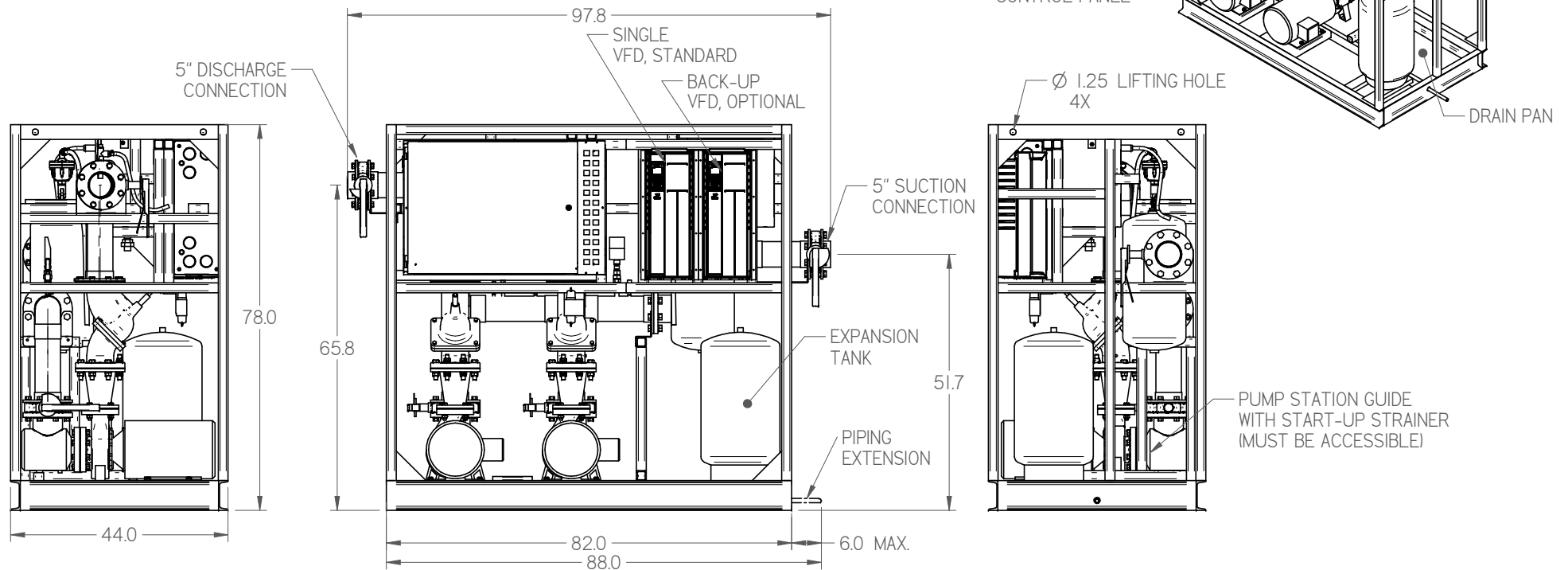

NOTES:

- IT IS THE RESPONSIBILITY OF THE INSTALLING CONTRACTOR TO ENSURE THAT THE FINAL EQUIPMENT INSTALLATION MEETS ALL APPLICABLE CODE REQUIREMENTS.
- ILLUSTRATION SHOWN IS FOR GENERAL REPRESENTATION ONLY. ACTUAL PRODUCT WILL VARY DEPENDENT UPON APPLICATION.
- OVERALL DIMENSIONS: 97.8 L X 44.0 W X 78.0 H.

DIMENSIONS ARE IN INCHES.
DATE DRAWN: 2017/09/15



INFORMATION SUBJECT TO CHANGE

SHEET 1 OF 3

HUSSmann®

PUMP STATION-400
AND 450 GPM
ARMSTRONG

DOC PD-00000024 REV B

SWIN10 SUBMITTAL SHEET SIZE D

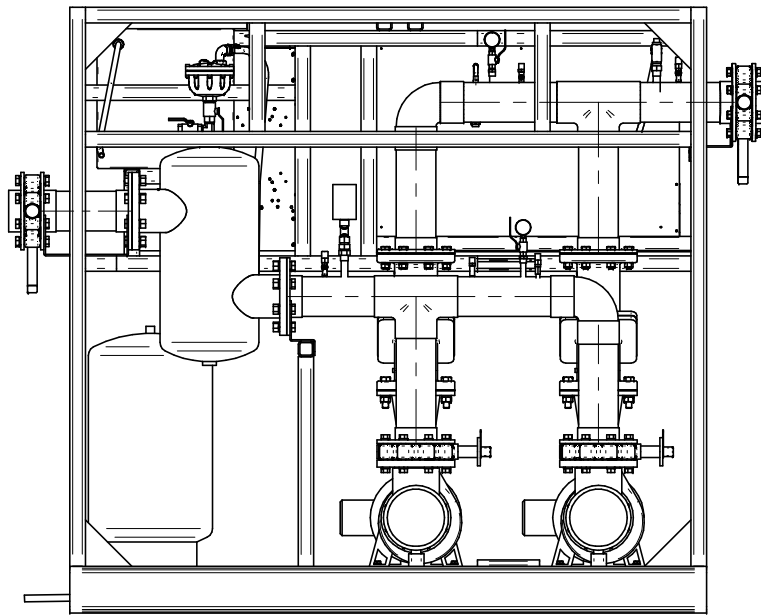

BACK VIEW

NOTES:

1. IT IS THE RESPONSIBILITY OF THE INSTALLING CONTRACTOR TO ENSURE THAT THE FINAL EQUIPMENT INSTALLATION MEETS ALL APPLICABLE CODE REQUIREMENTS.
2. ILLUSTRATION SHOWN IS FOR GENERAL REPRESENTATION ONLY. ACTUAL PRODUCT WILL VARY DEPENDENT UPON APPLICATION.
3. OVERALL DIMENSIONS: 97.8 L X 44.0 W X 78.0 H.

DIMENSIONS ARE IN INCHES.
DATE DRAWN: 2017/09/15



HUSSmann®

PUMP STATION-400
AND 450 GPM
ARMSTRONG

INFORMATION SUBJECT TO CHANGE

SHEET 2 OF 3

DOC PD-000000024 REV B

SHEET SUBMITTAL SHEET SIZE D

MINIMUM CLEARANCE REQUIREMENTS:
 ACTUAL CLEARANCE REQUIREMENTS
 ARE DEPENDENT UPON AUTHORITY
 HAVING JURISDICTION, AND MAY EXCEED
 DIMENSIONS SHOWN.

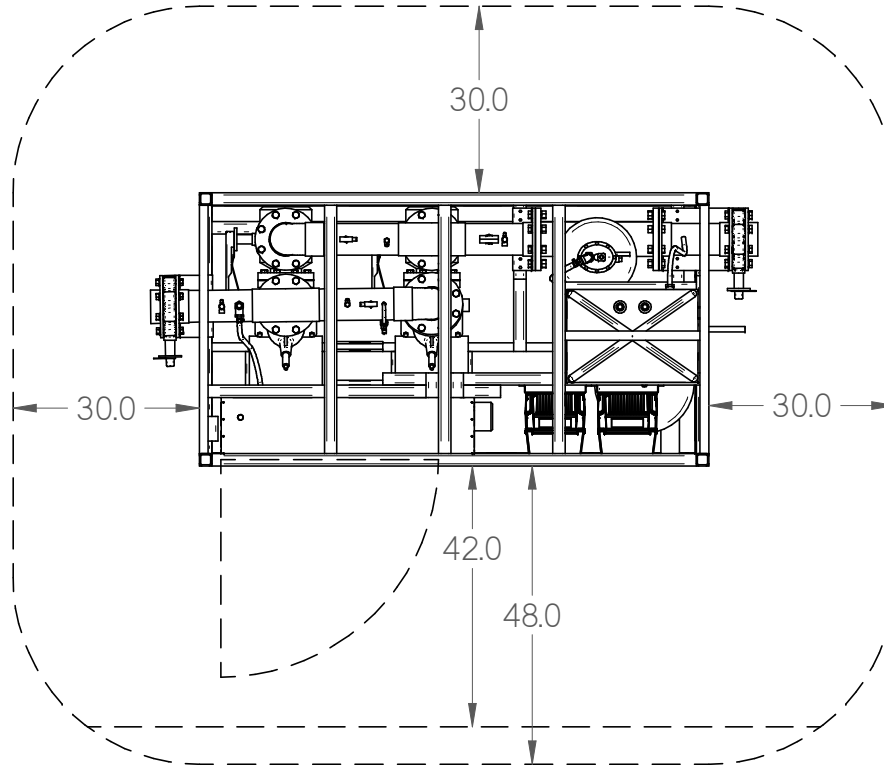

42" CLEARANCE BETWEEN
 CONTROL PANEL & ANY WALL.

48" CLEARANCE BETWEEN
 CONTROL PANEL & ANY LIVE
 PANEL.

NOTES:

1. IT IS THE RESPONSIBILITY OF THE INSTALLING CONTRACTOR TO ENSURE THAT THE FINAL EQUIPMENT INSTALLATION MEETS ALL APPLICABLE CODE REQUIREMENTS.
2. ILLUSTRATION SHOWN IS FOR GENERAL REPRESENTATION ONLY. ACTUAL PRODUCT WILL VARY DEPENDENT UPON APPLICATION.
3. OVERALL DIMENSIONS: 97.8 L X 44.0 W X 78.0 H.

DIMENSIONS ARE IN INCHES.
 DATE DRAWN: 2017/09/15



THIRD
 ANGLE
 PROJECTION

HUSSmann®

PUMP STATION-400
 AND 450 GPM
 ARMSTRONG

DOC PD-000000024 REV B

INFORMATION SUBJECT TO CHANGE

SHEET 3 OF 3

SHEET SUBMITTAL SHEET SIZE D