

<b>HUSSMANN</b> <sup>®</sup> /CHINO	Installation & Operation Manual
ISM	REV. 0909
ISLAND CHEESE/DELI CASE	

# HUSSMANN<sup>®</sup>

ISM  
CHEESE/DELI ISLAND CASE



P/N IGIC-ISM-0909

---

INSTALLATION & OPERATION GUIDE

**General Instructions**

**Table of Contents**

**General Instructions**.....2  
**Cut and Plan Views** .....3  
**Installation**.....3  
 Location .....3  
 Uncrating the Stand .....3  
 Exterior Loading.....3  
 Leveling .....3  
 Bumper Installation Instructions.....4  
**Plumbing** .....7  
 Waste Outlet and P-TRAP .....7  
 Installing Condensate Drain.....7  
**Refrigeration** .....7  
 Refrigerant Type .....7  
 Refrigeration Lines.....7  
 Control Settings .....7  
 Access to TX Valves and Drain Lines.....7  
 Electronic Expansion Valve (Optional).....7  
 Thermostatic Expansion Valve Location .....8  
 Expansion Valve Adjustment .....8  
 Measuring the Operating Superheat.....8  
 T-STAT Location .....8  
 Thermometer Location.....8  
 Refrigeration Data.....8  
 Defrost Data.....8  
 Physical Data.....8  
 Glycol Requirements .....8  
**Electrical**.....9  
 Wiring Color Code .....9  
 Electrical Circuit Identification.....9  
 Electrical Service Receptacles (When Applicable) .....9  
 Field Wiring and Serial Plate Amperage.....9  
 Ballast Location .....9  
**User Information**.....10  
 Stocking .....10  
 Case Cleaning .....10  
 Cleaning Mirrors .....10  
 Plexiglass and Acrylic Care .....10  
 Cleaning.....10  
 Waxing .....11  
 Antistatic Coatings .....11  
**Maintenance**.....11  
 Evaporator Fans .....11  
 Copper Coils .....11  
 Tips and Troubleshooting .....11  
 Access Panels .....11  
 Stainless Steel Cleaning and Care .....11  
**Electrical Wiring Diagrams** .....12  
**Wiring Diagrams** .....13  
**Appendices** .....15  
 Appendix A. - Temperature Guidelines .....15  
 Appendix B. - Application Recommendations.....15  
 Appendix C. - Field Recommendations .....15  
 Appendix D. - Recommendations to User .....16

**This Booklet Contains Information on:**  
**ISM Refrigerated Mini-Island Display:**

**Shipping Damage**

All equipment should be thoroughly examined for shipping damage before and during unloading.

This equipment has been carefully inspected at our factory and the carrier has assumed responsibility for safe arrival. If damaged, either apparent or concealed, claim must be made to the carrier.

**Apparent Loss or Damage**

If there is an *obvious loss or damage*, it must be noted on the freight bill or express receipt and signed by the carrier's agent; otherwise, carrier may refuse claim. The carrier will supply necessary claim forms.

**Concealed Loss or Damage**

When loss or damage *is not apparent until after equipment is uncrated*, a claim for concealed damage is made. Make request in writing to carrier for inspection within 15 days, and retain all packaging. The carrier will supply inspection report and required claim forms.

**Shortages**

Check your shipment for any possible shortages of material. If a shortage should exist and is found to be the responsibility of Hussmann Chino, *notify Hussmann Chino*. If such a shortage involves the carrier, *notify the carrier immediately*, and request an inspection. Hussmann Chino will acknowledge shortages within ten days from receipt of equipment.

**Hussmann Chino Product Control**

The serial number and shipping date of all equipment has been recorded in Hussmann's files for warranty and replacement part purposes. All correspondence pertaining to warranty or parts ordering must include the serial number of each piece of equipment involved, in order to provide the customer with the correct parts.

Keep this booklet with the case at all times for future reference.

**HUSSMANN®/CHINO**

A publication of HUSSMANN® Chino  
 13770 Ramona Avenue • Chino, California 91710  
 (909) 628-8942 FAX  
 (909) 590-4910  
 (800) 395-9229



**This equipment is to be installed to comply with the applicable NEC, Federal, State, and Local Plumbing and Construction Code having jurisdiction.**

**Cut and Plan Views**

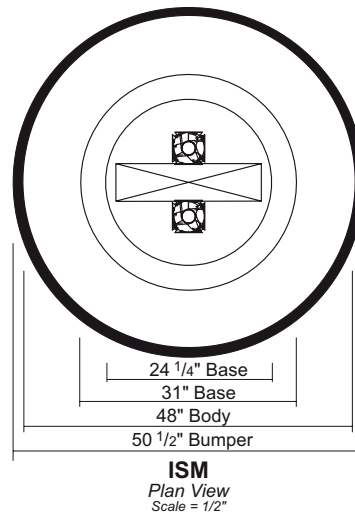
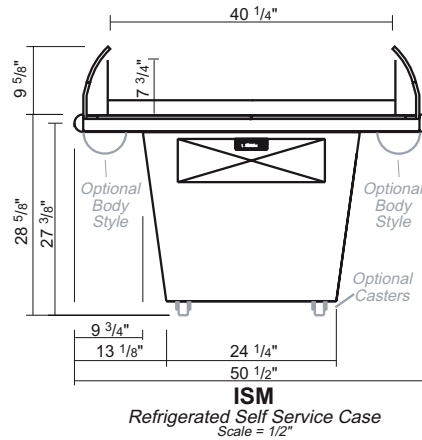

**Installation**

**Location**

The refrigerated merchandisers have been designed for use only in air conditioned stores where temperature and humidity are maintained at or below 75°F and 55% relative humidity. DO NOT allow air conditioning, electric fans, ovens, open doors or windows (etc.) to create air currents around the merchandiser, as this will impair its correct operation.

Product temperature should always be maintained at a constant and proper temperature. This means that from the time the product is received, through storage, preparation and display, the temperature of the product must be controlled to maximize life of the product.

**Uncrating the Stand**

Place the fixture as close to its permanent position as possible. Remove the top of the crate. Detach the walls from each other and remove from the skid. Unbolt the case from the skid. The fixture can now be lifted off the crate skid. **Lift only at base of stand!**

**Exterior Loading**

These models have **not** been structurally designed to support excessive external loading. **Do not walk on their tops;** This could cause serious personal injury and damage to the fixture.

**Leveling**

**IMPORTANT! IT IS IMPERATIVE THAT CASES BE LEVELED FROM FRONT TO BACK AND SIDE TO SIDE PRIOR TO JOINING. A LEVEL CASE IS NECESSARY TO INSURE PROPER OPERATION, WATER DRAINAGE, PLEXIGLASS ALIGNMENT. LEVELING THE CASE CORRECTLY WILL SOLVE MOST HINGE OPERATION PROBLEMS.**

**NOTE:** A. To avoid removing concrete flooring, begin lineup leveling from the highest point of the store floor.

B. When wedges are involved in a lineup, set them first.

All cases were leveled and joined prior to shipment to insure the closest possible fit when cases are joined in the field. When joining, use a carpenters level and shim legs accordingly. Case must be raised correctly, under legs where support is best, to prevent damage to case.

### Installation (Cont'd)

1. Check level of floor where cases are to be set. Determine the highest point of the floor; cases will be set off this point.
2. Set first case, and adjust legs over the highest part of the floor so that case is level. Prevent damage - case must be raised under leg or by use of 2x6 or 2x4 leg brace. Remove side and back leg braces after case is set.



**ATTENTION  
INSTALLER**

**It is the contractor's responsibility to install case(s) according to local construction and health codes.**

### Bumper Installation Instructions



Step 1: Make sure the aluminum channel and end caps are installed.



Step 2: Use silicone lubricant to help the bumper slide into the channel.



Step 3: Starting on one end, while inserting the bumper, push it up against the end cap to prevent the bumper from shrinking after installation (when it gets cold).



Step 4: As you insert the bumper into the channel with one hand, pull the bumper toward you with the other to open the inside lips. Slowly apply pressure by rolling the bumper into the track.

## Installation (Cont'd)

### Boston Series 2000

**NOTE:** Flexible top: Over cut vinyl 1/8" for every 4' section for the flexible top to ensure a proper fit.

**NOTE:** Rigid Top: Do not over cut.



1. Attach the base and end/corner cap to the desired surface by inserting #8 pan head screws through the pre-slotted holes in both the end cap and the base. Insert screws through the two holes of end cap and tighten.



- 2a. **Flexible Top:** Butt end of the vinyl top against end/corner cap. While applying pressure, bend back vinyl top so that vinyl legs are positioned within the base grooves. Roll vinyl top over full length of base, then tap with rubber mallet to ensure vinyl is securely locked into the base.

- 2b. **Rigid Top:** Snap the Rigid Top over the Rigid Base.



3. If necessary wipe clean with any household cleaning product.

**Helpful Hints:**

- For best results, before cutting, install a scrap piece of base into vinyl top to achieve a clean cut.
- Set the uncoiled flexible vinyl at room temperature 24 hours prior to installation.
- Lubricate the inside of the vinyl with soapy water or silicone before installing.
- Over cut the flexible vinyl and compression fit. Adding the additional materials will compensate for stretching which occurs during installation.

### Boston 2000 Eco Series



1. Attach the base and end/corner cap to the desired surface by inserting #8 pan head screws through the pre-slotted holes in both the end cap and the base. Insert screws through the two holes of end cap and tighten.



- 2a. **Flexible Top:** Butt end of the vinyl top against end/corner cap. While applying pressure, bend back vinyl top so that vinyl legs are positioned within the base grooves. Roll vinyl top over full length of base, then tap with rubber mallet to ensure vinyl is securely locked into the base.

- 2b. **Rigid Top:** Snap the Rigid Top over the Rigid Base.



3. If necessary wipe clean with any household cleaning product.

**Helpful Hints:**

- For best results, before cutting, install a scrap piece of base into vinyl top to achieve a clean cut.
- Set the uncoiled flexible vinyl at room temperature 24 hours prior to installation.
- Lubricate the inside of the vinyl with soapy water or silicone before installing.
- Over cut the flexible vinyl and compression fit. Adding the additional materials will compensate for stretching which occurs during installation.

## Installation (Cont'd)

### Boston 1000 Series

**NOTE:** Flexible top: Over cut vinyl 1/8" for every 4' section for the flexible top to ensure a proper fit.

**NOTE:** Rigid Top: Do not over cut.

#### Installation

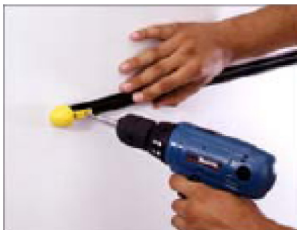

1. Attach the base and end/corner cap to the desired surface by inserting #8 pan head screws through the pre-slotted holes in both the end cap and the base. Insert screws through the two holes of end cap and tighten.

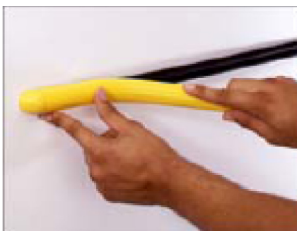

- 2a. **Flexible Top:** Butt end of the vinyl top against end/corner cap. While applying pressure, bend back vinyl top so that vinyl legs are positioned within the base grooves. Roll vinyl top over full length of base, then tap with rubber mallet to ensure vinyl is securely locked into the base.

- 2b. **Rigid Top:** Snap the Rigid Top over the Rigid Base.



3. If necessary wipe clean with any household cleaning product.

#### Helpful Hints:

- For best results, before cutting, install a scrap piece of base into vinyl top to achieve a clean cut.
- Set the uncoiled flexible vinyl at room temperature 24 hours prior to installation.
- Lubricate the inside of the vinyl with soapy water or silicone before installing.
- Over cut the flexible vinyl and compression fit. Adding the additional materials will compensate for stretching which occurs during installation.

## Plumbing

### Waste Outlet and P-TRAP

The waste outlet is located off the center of the case on one side allowing drip piping to be run lengthwise under the fixture.

A 1-1/2" P-TRAP and thread adapter are supplied with each fixture. The P-TRAP must be installed to prevent air leakage and insect entrance into the fixture.

**NOTE:** PVC-DWV solvent cement is recommended. Follow the manufacturer's instructions.

### Installing Condensate Drain

Poorly or improperly installed condensate drains can seriously interfere with the operation of this refrigerator, and result in costly maintenance and product losses. Please follow the recommendations listed below when installing condensate drains to insure a proper installation:

1. Never use pipe for condensate drains smaller than the nominal diameter of the pipe or P-TRAP supplied with the case.
2. When connecting condensate drains, the P-TRAP must be used as part of the condensate drain to prevent air leakage or insect entrance. Store plumbing system floor drains should be at least 14" off the center of the case to allow use of the P-TRAP pipe section. Never use two water seals in series in any one line. Double P-TRAPS in series will cause a lock and prevent draining.

3. Always provide as much down hill slope ("fall") as possible; 1/8" per foot is the preferred minimum. PVC pipe, when used, must be supported to maintain the 1/8" pitch and to prevent warping.
4. Avoid long runs of condensate drains. Long runs make it impossible to provide the "fall" necessary for good drainage.
5. Provide a suitable air break between the flood rim of the floor drain and outlet of condensate drain. 1" is ideal.
6. Prevent condensate drains from freezing:
  - a. Do not install condensate drains in contact with non-insulated suction lines. Suction lines should be insulated with a non absorbent insulation material such as Armstrong's Armaflex.
  - b. Where condensate drains are located in dead air spaces (between refrigerators or between a refrigerator and a wall), provide means to prevent freezing. The water seal should be insulated to prevent condensation.

## Refrigeration

### Refrigerant Type

The standard refrigerant will be R-404A or R22 unless otherwise specified on the customer order. Check the serial plate on the case for information. Minimum opening for self contained condenser units - 150 sq. inch up to 1-1/2 hp, 200 sq. inch for over 1-1/hp.

### Refrigeration Lines

<u>Liquid</u>	<u>Suction</u>
3/8" O.D.	5/8" O.D.

**NOTE:** The standard coil is piped at 5/8" (suction); however, the store tie-in may vary depending on the number of coils and the draw the case has. Depending on the case setup, the connecting point in the store may be 5/8", 7/8", or 1 1/8". Refer to the particular case you are hooking up.

Refrigerant lines should be sized as shown on the refrigeration legend furnished by the store.

Install **P-TRAPS** (oil traps) at the base of all suction line vertical risers.

**Pressure drop** can rob the system of capacity. To keep the pressure drop to a minimum, keep refrigerant line run as short as possible, using the minimum number of elbows. Where elbows are required, use long radius elbows only.

### Control Settings

See ISM technical data sheet for the appropriate settings for your merchandiser. Maintain these parameters to achieve near constant product temperatures. Product temperature should be measured first thing in the morning, after having been refrigerated overnight. Defrost times should be as follows: OFF CYCLE - Defrost times should be as directed in the ISM technical data sheet. The number of defrosts per day and the duration of the defrost cycle may be adjusted to meet conditions present at your location.

### Access to TX Valves and Drain Lines

**Mechanical** - Remove product from end of case. Remove product racks. Remove refrigeration and drain access panels (labeled). TX valve (mechanical only) and drain are located under each access panel at end of the case.

**Electronic** - The Electronic Expansion valve master and slave cylinder(s) are located within the electrical access panel(s).

### Electronic Expansion Valve (Optional)

A wide variety of electronic expansion valves and case controllers can be utilized. Please refer to EEV and controller manufacturers information sheet. Sensors for electronic expansion valves will be installed on the coil inlet, coil outlet, and in the discharge air. (Some supermarkets require a 4th sensor in the return air). Case controllers will be located in the electrical raceway or under the case.

## Refrigeration (Cont'd)

### Thermostatic Expansion Valve Location

This device is located on the same side as the refrigeration stub. A Sporlan balanced port expansion valve model is furnished as standard equipment, unless otherwise specified by customer.

### Expansion Valve Adjustment

Expansion valves must be adjusted to fully feed the evaporator. Before attempting any adjustments, make sure the evaporator is either clear or very lightly covered with frost, and that the fixture is within 10°F of its expected operating temperature.

### Measuring the Operating Superheat

1. Determine the suction pressure with an accurate pressure gauge at the evaporator outlet.
2. From a refrigerant pressure temperature chart, determine the saturation temperature at the observed suction pressure.
3. Measure the temperature of the suction gas at the thermostatic remote bulb location.
4. Subtract the saturation temperature obtained in step No. 2 from the temperature measured in step No. 3. The difference is superheat.
5. Set the superheat for 5°F - 7°F.

### T-STAT Location

T-STATS are located within the electrical raceway. Refer to diagram below.

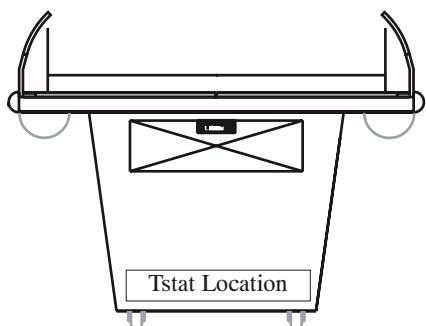

**ISM  
T-Stat Locations**

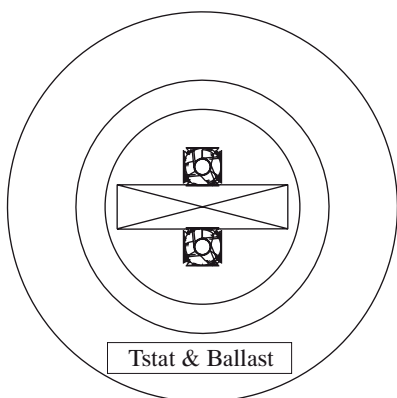

**ISM  
Plan View**

### Thermometer Location

Thermometer is located at the warmest part of the unit as determined by the factory. This thermometer is factory installed.

### Refrigeration Data

**Note:** This data is based on store temperature and humidity that does not exceed 75F and 55% R.H.

**Discharge Air (F) 28**

**Evaporator (F) 18**

**Note:** Not recommended to control temp by regulating coil temp allow T-STAT to cycle and control temp.

### Btu/hr/ft\*

**Parallel 500**

**Conventional 575**

\*For all refrigeration equipment other than Hussmann use conventional Btu values.

### Defrost Data

**Frequency Hrs 8**

### OFFTIME

**Temp Term °F 54**

**Failsafe Minutes 46**

### ELECTRIC or GAS Not Recommended

### Physical Data

Merchandiser Drip Pipe (in.) 1½

Merchandiser Liquid Line (in.) 3/8\*

Merchandiser Suction Line (in.) 5/8\*

### Estimated Charge (lb)\*\*\*

4ft 1.2

5ft 1.5

6ft 1.8

\*Dependent on case length and refrigerant type.

\*\*\* This is an average for all refrigerants types. Actual refrigerant charge may vary by approximately half a pound.

### Glycol Requirements

GPM	PSI
N/A	N/A
N/A	N/A
N/A	N/A



**Electrical**

**Wiring Color Code**

STANDARD CASE WIRE COLOR CODE CODIGO DE COLORES DE LOS ALAMBRES PARA LAS VITRINAS ESTANDAR CODE COULER POUR FILS DE BOITIER NORMALISE		
COLOR DESCRIPTION	DESCRIPCION	DESCRIPTION
■ GROUND	TIERRA MASA	MASSE
■ ANTI-SWEAT	ANTICONDENSACION	ANTI-SUINTEMENT
■ LIGHTS	LUCES	ECLAIRAGE
■ RECEPTACLES	ENCHUFES	PRISE DE COURANT
■ T-STAT/SOLENOID 230VAC	TERMOSTATO/SOLENOIDE (230VAC)	SOUPAPE A SOLENOID (230 VAC)
■ T-STAT/SOLENOID 115VAC	TERMOSTATO/SOLENOIDE (115VAC)	SOUPAPE A SOLENOID (115 VAC)
■ T-STAT/SOLENOID 24VAC	TERMOSTATO/SOLENOIDE (24VAC)	SOUPAPE A SOLENOID (24 VAC)
■ FAN MOTORS	VENTILADORES	VENTILATEUR
BLUE CONDENSING UNIT	UNIDAD DE CONDENSACION	UNITE DE CONDENSATION

**USE COPPER CONDUCTORS ONLY**  
**UTILISEZ LES CONDUCTEURS DE CUIVRE SEULEMENT**  
**UTILICE LOS CONDUCTORES DE COBRE SOLAMENTE**  
 430-01-0338 R101003

**CASE MUST BE GROUNDED**

**NOTE:** Refer to label affixed to case to determine the actual configuration as checked in the "TYPE INSTALLED" boxes.

**Electrical Circuit Identification**

Standard lighting for all models will be full length fluorescent lamps located within the case at the top.

The switch controlling the lights, the plug provided for digital scale, and the thermometer are located at the rear of the case mullion.

The receptacle that is provided on the exterior back of these models is intended for computerized scales with a five amp maximum load, not for large motors or other high wattage appliances. It should be wired to a dedicated circuit.

**Electrical Service Receptacles (When Applicable)**

The receptacles located on the exterior of the merchandiser are intended for scales and lighted displays. They are not intended nor suitable for large motors or other external appliances.



**DANGER**

**BEFORE SERVICING**  
**ALWAYS DISCONNECT ELECTRICAL**  
**POWER AT THE MAIN DISCONNECT**  
**WHEN SERVICING OR REPLACING ANY**  
**ELECTRICAL COMPONENT.**

**This includes (but not limited to) Fans, Heaters**  
**Thermostats, and Lights.**

**Field Wiring and Serial Plate Amperage**

Field Wiring must be sized for component amperes printed on the serial plate. Actual ampere draw may be less than specified. Field wiring from the refrigeration control panel to the merchandisers is required for refrigeration thermostats. Case amperes are listed on the wiring diagram, but always check the serial plate.

**Ballast Location**

Ballasts are located within the access panel that runs the length of the rear of the case.

## User Information

### Stocking

Improper temperature and lighting will cause serious product loss. Discoloration, dehydration and spoilage can be controlled with proper use of the equipment and handling of product. Product temperature should always be maintained at a constant and proper temperature. This means that from the time the product is received, through storage, preparation and display, the temperature of the product must be controlled to maximize life of the product. Hussmann cases were not designed to "heat up" or "cool down" product-but rather to maintain an item's proper temperature for maximum shelf life. To achieve the protection required always:

1. Minimize processing time to avoid damaging temperature rise to the product. Product should be at proper temperature.
2. Keep the air in and around the case area free of foreign gasses and fumes or food will rapidly deteriorate.
3. Maintain the display merchandisers temperature controls as outlined in the refrigerator section of this manual.
4. Do not place any product into these refrigerators until all controls have been adjusted and they are operating at the proper temperature. Allow merchandiser to operate a minimum of 6 hours before stocking with any product.
5. The load limit is to the top of the inside Plexiglass product stop or 6" above the deck pan. **Air discharge and return air flue must be unobstructed at all times to provide proper refrigeration.**
6. Keep the service doors closed (when applicable). Refrigeration performance will be seriously affected if left open for a prolonged period of time.
7. Avoid the use of supplemental flood or spot lighting. Display light intensity has been designed for maximum visibility and product life at the factory. The use of higher output fluorescent lamps (H.O. and V.H.O.), will shorten the shelf life of the product.

### Case Cleaning

Long life and satisfactory performance of any equipment are dependent upon the care given to it. To insure long life, proper sanitation and minimum maintenance costs, the refrigerator should be thoroughly cleaned frequently. The discoloration which causes deli items to lose their eye appeal and drastically shorten their shelf life is caused by bacteria which will thrive in a deli department.

**NOTE:** Soap and hot water are not enough to kill this bacteria. A sanitizing solution must be included with each cleaning process to eliminate this bacteria.

### SHUT OFF FANS DURING CLEANING PROCESS!

They (it) can be unplugged within the case, or shut off case at the source.

- A. Scrub all surfaces thoroughly with any domestic soap, detergent, or even ammonia based cleaners.
- B. Rinse with hot water, but do not flood.
- C. Dirt and residue may accumulate in the space between the back interior wall, bottom and the evaporator coil. This should be cleaned out using a low pressure water hose and a bottle brush to loosen up and flush the debris under the coil into the drain through. \*\* see the CLEANING PRECAUTIONS below.
- D. Apply the sanitizing solution according to the manufacturers directions.
- E. Rinse thoroughly.
- F. Dry completely before resuming operation.

### Cleaning Mirrors

Only use a soft cloth and water for cleaning any mirrored components. Be sure to rinse and/or dry completely.

## CAUTION

### CLEANING PRECAUTIONS

#### When cleaning:

- Do not use high pressure water hoses
- Do not introduce water faster than waste outlet can drain
- NEVER INTRODUCE WATER ON SELF CONTAINED UNIT WITH AN EVAPORATOR PAN
- NEVER USE A CLEANING OR SANITIZING SOLUTION THAT HAS AN OIL BASE (these will dissolve the butyl sealants) or an AMMONIA BASE (this will corrode the copper components of the case)
- TO PRESERVE THE ATTRACTIVE FINISH:
- DO USE WATER AND A MILD DETERGENT FOR THE EXTERIOR ONLY
- DO NOT USE A CHLORANATED CLEANER ON ANY SURFACE
- DO NOT USE ABRASIVES OR STEEL WOOL SCOURING PADS (these will mar the finish)

**Never use hot water on cold glass surfaces! It may shatter and cause serious injury!** Allow glass surfaces to warm first.

### Plexiglass and Acrylic Care

Improper cleaning not only accelerates the cleaning cycle but also degrades the quality of this surface. Normal daily buffing motions can generate static cling attracting dust to the surface. Incorrect cleaning agents or cleaning cloths can cause micro scratching of the surface, causing the plastic to haze over time.

### Cleaning

Clean with plenty of nonabrasive soap or detergent and luke warm water, using the bare hand to feel and dislodge any caked-on dirt. A soft grit free cloth, sponge or chamois may be used, but only as a means of carrying the water to the plastic. Dry with clean damp chamois or clean soft cloth such as cotton flannel. Hard, rough cloths or paper towels will scratch the acrylic and should not be used.

**User information (Cont'd)**

**Waxing**

If after removing dirt and grease, the acrylic can be waxed with a good grade commercial wax. This will improve the appearance of the surface by filling in most minor scratches. Wax should be applied in a thin even coat and brought to a high polish by rubbing lightly with a dry clean soft cloth, such as a cotton flannel. Excessive rubbing may cause scratching and/or buildup an electrostatic charge which attracts dust and dirt to the surface. Blotting with a clean damp cloth is recommended to remove charge.

**Antistatic Coatings**

For acrylic used indoors, antistatic coatings successfully prevent the accumulation of an electrostatic charge for periods of several months - if the surface is not washed or wiped down with a wet cloth. Between applications of the antistatic coatings, the parts need only be dusted with a soft clean cloth to maintain a good appearance. In use, liquid antistatic coatings should be applied in a very thin even coat. If beads appear as it is applied, the coat is too thick and the excess should be removed with another cloth. Allow the coating to dry, then bring to a high gloss with a soft cloth.

**Maintenance**



**DANGER**

**BEFORE SERVICING**

Disconnect both Attachment Plugs to completely De-energize unit. Failure to disconnect both plugs may result in damage to equipment, serious personal injury! This includes (but not limited to) Fans, Heaters, Thermostats and Lights.



**IMPORTANT INFORMATION**

**FOR PROMPT SERVICE**

**When Contacting the Factory for support, Be sure to have the CASE MODEL and SERIAL NUMBER Handy. This Information is on a plate located on the case itself.**

**Evaporator Fans**

The evaporator fans are located in front of the CAD, directly beneath the display pans. *Should fans or blades need servicing, always replace fan blades with the raised embossed side of the blade TOWARD THE MOTOR.*

**Copper Coils**

The copper coils used in Hussmann merchandisers may be repaired in the field. Materials are available from local refrigeration wholesalers.

Hussmann recommends using #15 Sil-Fos for repairs.

**Tips and Troubleshooting**

**Before calling for service, check the following:**

1. Check electrical power supply to the equipment for connection.
2. Check fixture loading. Overstocking case will affect its proper operation.
3. If frost is collecting on fixture and/or product, check that no outside doors or windows are open-allowing moisture to enter store.

**Access Panels**

All ELECTRICAL and drain access panels are clearly labeled on the deck of the deli/cheese stand. The access for condensing units (in the self contained units) is located on the side of the stand, at the end. Ends of stand are fitted for removal, if condensing unit has to be taken out.

**Stainless Steel Cleaning and Care**

There are three basic things, which can break down your stainless steel's passivity layer and allow corrosion.

**1. Mechanical Abrasion**

Mechanical Abrasion means those things that will scratch the steels surface. Steel Pads, wire Brushes, and Scrapers are prime examples.

**2. Water**

Water comes out of our tap in varying degrees of hardness. Depending on what part of the country you live in, you may have hard or soft water. Hard water may leave spots. Also, when heated, hard water leaves deposits behind that if left to sit, will break down the passive layer and rust your stainless steel. Other deposits from food preparation and service must be properly removed.

**3. Chlorides**

Chlorides are found nearly everywhere. They are in water, food and table salt. One of the worst perpetrators of chlorides can come from household and industrial cleaners.

## Maintenance (Cont'd)

Don't Despair! Here are a few steps that can help prevent stainless steel rust.

### 1. Use the Proper Tools

When cleaning your stainless steel products, take care to use non-abrasive tools. Soft Clothes and plastic scouring pads will NOT harm the steel's passive layer. Stainless steel pads can also be used but the scrubbing motion must be in the same direction of the manufacturer's polishing marks.

### 2. Clean With the Polish Lines

Some stainless steels come with visible polishing lines or "grain". When visible lines are present, you should ALWAYS scrub in a motion that is parallel to them. When the grain cannot be seen, play it safe and use a soft cloth or plastic scouring pad.

### 3. Use Alkaline, Alkaline Chlorinated or Non-chloride Containing Cleaners

While many traditional cleaners are loaded with chlorides, the industry is providing an ever increasing choice of non-chloride cleaners. If you are not sure of your cleaner's chloride content contact your cleaner supplier. If they tell you that your present cleaner contains chlorides, ask for an alternative. Also, avoid cleaners containing quaternary salts as they also can attack stainless steel & cause pitting and rusting.

### 4. Treat your Water

Though this is not always practical, softening hard water can do much to reduce deposits. There are certain filters that can be installed to remove distasteful and corrosive elements. Salts in a properly maintained water softener are your friends. If you are not sure of the proper water treatment, call a treatment specialist.

### 5. Keep your Food Equipment Clean

Use alkaline, alkaline chlorinated or non-chlorinated cleaners at recommended strength. Clean frequently to avoid build-up of hard, stubborn stains. If you boil water in your stainless steel equipment, remember the single most likely cause of damage is chlorides in the water. Heating cleaners that contain chlorides has a similar effect.

### 6. RINSE, RINSE, RINSE

If chlorinated cleaners are used you must rinse, rinse, rinse and wipe dry immediately. The sooner you wipe off standing water, especially when sit contains cleaning agents, the better. After wiping the equipment down, allow it to air dry for the oxygen helps maintain the stainless steel's passivity film.

### 7. Never Use Hydrochloric Acid (Muriatic Acid) on Stainless Steel

### 8. Regularly Restore/Passivate Stainless Steel

## Electrical Wiring Diagrams

ISM	With Power Cord/R404A	4'	1H07120
	With Power Cord	4'	W5000388

Wiring Diagrams

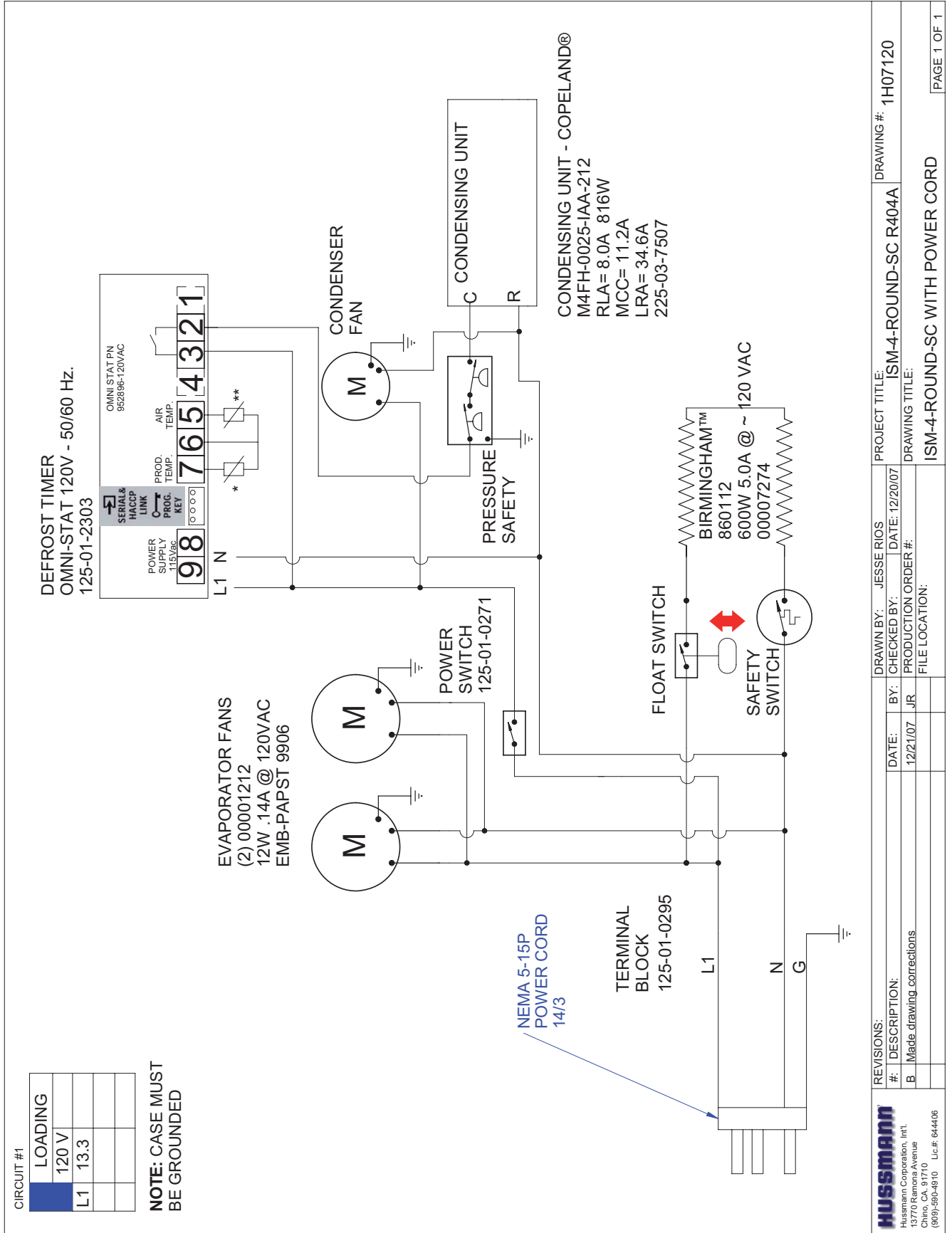

CIRCUIT #1

LOADING
120 V
L1 13.3

**NOTE: CASE MUST BE GROUNDED**

Wiring Diagrams (Cont'd)

CIRCUIT #1

LOADING	
115V	
L1	14.4 ##
L2	0.0 ##
L3	##

NOTE: CASE MUST BE GROUNDED

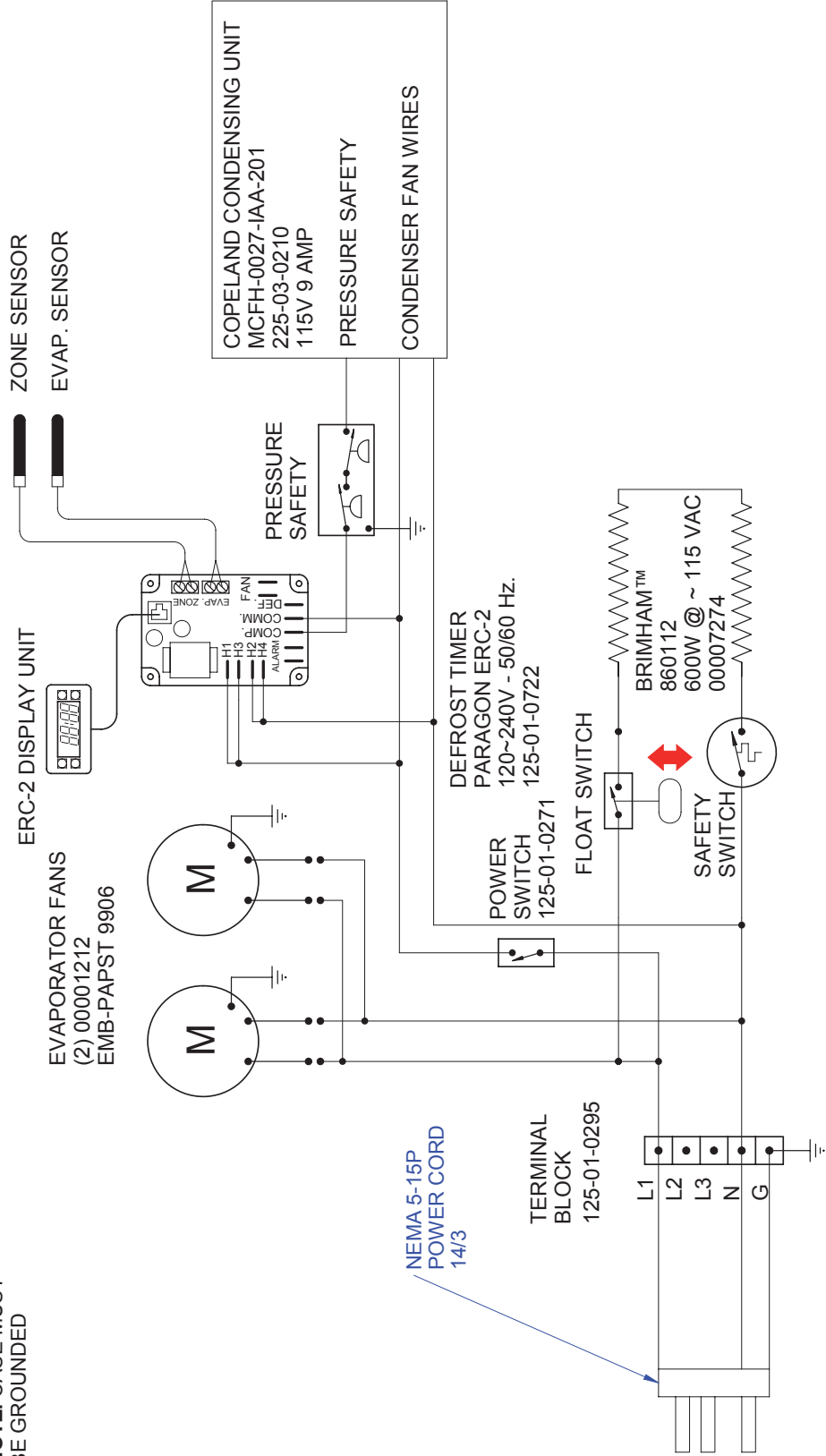

REVISIONS:		DRAWN BY: DENNY QUAN	PROJECT TITLE: ISM-4-ROUND-SC	DWG #: W5000388
1	DESCRIPTION:	CHECKED BY: --	DATE: 01/07/05	
2		PRODUCTION ORDER #: #####	DRAWING TITLE:	
3		FILE LOCATION:	ISM-4-ROUND-SC WITH POWER CORD	PAGE 1 OF 1
		T:WIRESCHEMATICSNEW-WIRING		

**HUSSMANN**  
 HUSSMANN CORPORATION  
 1370 RAMONA AVENUE  
 CHINO, CA 91710  
 (909) 590-4910 LIC# 644406

Appendices

**Appendix A. - Temperature Guidelines**

The refrigerators should be operated according to the manufacturer’s published engineering specifications for entering air temperatures for specific equipment applications. Table 1 shows the typical temperature of the air entering the food zone one hour before the start of defrost and one hour after defrost for various categories of refrigerators. Refer to Appendix C for Field Evaluation Guidelines.

Type of Refrigerator	Typical Entering Air Temperature
<b>I. OPEN DISPLAY</b>	
A. Non frozen:	
1) Meat	28°F
2) Dairy/Deli	32°F
3) Produce	
a. Processed	36°F
b. Unprocessed	45°F
B. Frozen	0°F
C. Ice Cream	-5°F
<b>II. CLOSED DISPLAY</b>	
A. Non frozen:	
1) Meat	34°F
2) Dairy/Deli	34°F
3) Produce	
a. Processed	36°F
b. Unprocessed	45°F
B. Frozen	0°F
C. Ice Cream	-5°F

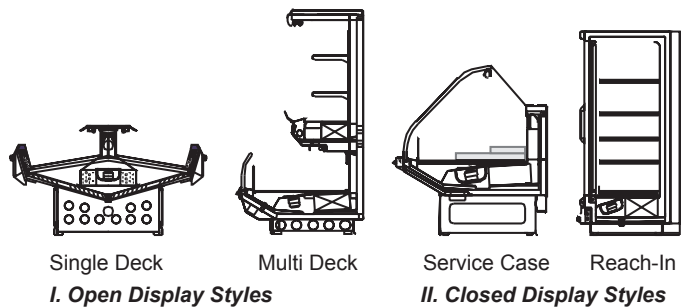

**Appendix B. - Application Recommendations**

- 1.0 Temperature performance is critical for controlling bacteria growth. Therefore, the following recommendations are included in the standard. They are based on confirmed field experience over many years.
  - 1.1 The installer is responsible for following the installation instructions and recommendations provided by Hussmann for the installation of each individual type refrigerator.
  - 1.2 Refrigeration piping should be sized according to the equipment manufacturer’s recommendations and installed in accordance with normal refrigeration practices. Refrigeration piping should be insulated according to Hussmann’s recommendations.

- 1.3 A clogged waste outlet blocks refrigeration. The installer is responsible for the proper installation of the system which dispenses condensate waste through an air gap into the building indirect waste system.
- 1.4 The installer should perform a complete start-up evaluation prior to the loading of food into the refrigerator, which includes such items as:
  - a) Initial temperature performance, Coils should be properly fed with a refrigerant according to manufacturer’s recommendations.
  - b) Observation of outside influences such as drafts, radiant heating from the ceiling and from lamps. Such influence should be properly corrected or compensated for.
  - c) At the same time, checks should be made of the store dry-bulb and wet-bulb temperatures to ascertain that they are within the limits prescribed by Hussmann.
  - d) Complete start-up procedures should include checking through a defrost to make certain of its adequate frequency and length without substantially exceeding the actual needs. This should include checking the electrical or refrigerant circuits to make sure that defrosts are correctly programmed for all the refrigerators connected to each refrigeration system.
  - e) Recording instruments should be used to check performance.

**Appendix C. - Field Recommendations**  
**Recommendations for field evaluating the performance of retail food refrigerators and hot cases**

- 1.0 The most consistent indicator of display refrigerator performance is temperature of the air entering the product zone (see Appendix A). In practical use, the precise determination of return air temperature is extremely difficult. Readings of return air temperatures will be variable and results will be inconsistent. The product temperature alone is not an indicator of refrigerator performance.

**NOTE:** Public Health will use the temperature of the product in determining if the refrigerator will be allowed to display potentially hazardous food. For the purpose of this evaluation, product temperature above the FDA Food Code 2005 temperature for potentially hazardous food will be the first indication that an evaluation should be performed. It is expected that all refrigerators will keep food at the FDA Food Code 2005 temperature for potentially hazardous food.

## Appendices (Cont'd)

- 1.1 The following recommendations are made for the purpose of arriving at easily taken and understood data which, coupled with other observations, may be used to determine whether a display refrigerator is working as intended:
- a) **INSTRUMENT** - A stainless steel stem-type thermometer is recommended and it should have a dial a minimum of 1 inch internal diameter. A test thermometer scaled only in Celsius or dually scaled in Celsius and Fahrenheit shall be accurate to 1°C (1.8°F). Temperature measuring devices that are scaled only in Fahrenheit shall be accurate to 2°F. The thermometer should be checked for proper calibration. (It should read 32°F when the stem is immersed in an ice water bath).
  - b) **LOCATION** - The probe or sensing element of the thermometer should be located in the airstream where the air first enters the display or storage area, and not more than 1 inch away from the surface and in the center of the discharge opening.
  - c) **READING** - It should first be determined that the refrigerator is refrigerating and has operated at least one hour since the end of the last defrost period. The thermometer reading should be made only after it has been allowed to stabilize, i.e., maintain a constant reading.
  - d) **OTHER OBSERVATIONS** - Other observations should be made which may indicate operating problems, such as unsatisfactory product, feel/appearance.
  - e) **CONCLUSIONS** - In the absence of any apparent undesirable conditions, the refrigerator should be judged to be operating properly. If it is determined that such condition is undesirable, i.e., the product is above proper temperature, checks should be made for the following:
    1. Has the refrigerator been loaded with warm product?
    2. Is the product loaded beyond the "Safe Load Line" markers?
    3. Are the return air ducts blocked?
    4. Are the entering air ducts blocked?
    5. Is a dumped display causing turbulent air flow and mixing with room air?
    6. Are spotlights or other high intensity lighting directed onto the product?
    7. Are there unusual draft conditions (from heating/air-conditioning ducts, open doors, etc.)?
    8. Is there exposure to direct sunlight?
    9. Are display signs blocking or diverting airflow?
    10. Are the coils of the refrigerator iced up?
    11. Is the store ambient over 75°F, 55% RH as set forth in ASHRAE Standard 72 and ASHRAE Standard 117?
    12. Are the shelf positions, number, and size other than recommended by Hussmann?
    13. Is there an improper application or control system?
    14. Is the evaporator fan motor/blade inoperative?
    15. Is the defrost time excessive?
    16. Is the defrost termination, thermostat (if used) set too high?
    17. Are the refrigerant controls incorrectly adjusted?
    18. Is the air entering the condenser above design conditions? Are the condenser fins clear of dirt, dust, etc.?
    19. Is there a shortage of refrigerant?
    20. Has the equipment been modified to use replacements for CFC-12, CFC-502 or other refrigerant? If so, have the modifications been made in accordance with the recommendations of the equipment manufacturer? Is the refrigerator charged with the proper refrigerant and lubricant? Does the system use the recommended compressor?

### Appendix D. - Recommendations to User

- 1.0 Hussmann Corporation provides instructions and recommendations for proper periodic cleaning. The user will be responsible for such cleaning, including the cleaning of low temperature equipment within the compartment and the cooling coil area(s). Cleaning practices, particularly with respect to proper refrigerator unloading and warm-up, must be in accordance with applicable recommendations.



---

**Appendices (Cont'd)**

- 1.1 Cleaning of non frozen food equipment should include a weekly cleaning of the food compartment as a minimum to prevent bacteria growth from accumulating. Actual use and products may dictate more frequent cleaning. Circumstances of use and equipment design must also dictate the frequency of cleaning the display areas. Weekly washing down of the storage compartment is also recommended, especially for equipment subject to drippage of milk or other liquids, or the collection of vegetable, meat, crumbs, etc. or other debris or litter. Daily cleaning of the external areas surrounding the storage or display compartments with detergent and water will keep the equipment presentable and prevent grime buildup.
- 1.2 Load levels as defined by the manufacturer must be observed.
- 1.3 The best preservation is achieved by following these rules:
- a) Buy quality products.
  - b) Receive perishables from transit equipment at the ideal temperature for the particular product.
  - c) Expedite perishables to the store's storage equipment to avoid unnecessary warm-up and prolonged temperature recovery. Food store refrigerators are not food chillers nor can they reclaim quality lost through previous mishandling.
  - d) Care must be taken when cross merchandising products to ensure that potentially hazardous vegetable products are not placed in non refrigerated areas.
  - e) Display and storage equipment doors should be kept closed during periods of inactivity.
  - f) Minimize the transfer time of perishables from storage to display.
  - g) Keep meat under refrigeration in meat cutting and processing area except for the few moments it is being handled in processing. When a cut or tray of meat is not to be worked on immediately, the procedure should call for returning it to refrigeration.
  - h) Keep tools clean and sanitized. Since mechanical equipment is used for fresh meat processing, all such equipment should be cleaned at least daily and each time a different kind of meat product comes in contact with the tool or equipment.
  - i) Make sure that all refrigeration equipment is installed and adjusted in strict accordance with the manufacturer's recommendations.
  - j) See that all storage and refrigeration equipment is kept in proper working order by routine maintenance.

---

## Service Record

Last service date:      By:

_____	_____
_____	_____
_____	_____
_____	_____
_____	_____
_____	_____
_____	_____

---

## HUSSmann®/Chino

Additional copies of this publication may be obtained by contacting:

Hussmann® Chino  
13770 Ramona Avenue • Chino, California 91710  
(909) 628-8942 FAX  
(909) 590-4910  
(800) 395-9229

The *MODEL NAME* and *SERIAL NUMBER* is required in order to provide you with the correct parts and information for your particular unit.

They can be found on a small metal plate on the unit.  
Please note them below for future reference.

**MODEL:**

**SERIAL NUMBER:**