

REVISION HISTORY						
REV	ECN	DATE	REVISION DESCRIPTION	REV BY	CHKD BY	APPR BY
A	-	2021/03/10	PRELIMINARY	VK	AMS	AMS



## CDRH - CONFIGURATION TABLE MXK CONDENSERS

MODEL	APPLICATION	DESIGN	COND	REFRIGERANT	MCA	MOPD	BASE FRAME	OVERALL UNIT	WEIGHT ( LBS )
MT-600K-CDRH-449	MT	600KBTUH	MXK08	57	151	175	295"LX99"W	308"LX102"WX84"H	10316
MT-400K-CDRH-449	MT	400KBTUH	MXK06	42	110	125	251"LX99"W	264"LX102"WX84"H	9800
MT-200K-CDRH-449	MT	200KBTUH	MXK04	27	73	80	207"LX99"W	220"LX102"WX84"H	8150
LT-80K-CDRH-449	LT	80KBTUH	MXK02	12	61	70	181"LX99"W	194"LX102"WX84"H	7500
LT-120K-CDRH-449	LT	120KBTUH	MXK04	27	92	100	207"LX99"W	220"LX102"WX84"H	8150
MT-400K-CDRH-513	MT	400KBTUH	MXK06	44	150	175	251"LX99"W	264"LX102"WX84"H	9800
MT-200K-CDRH-513	MT	200KBTUH	MXK04	29	100	125	207"LX99"W	220"LX102"WX84"H	8150
MT-LT-250K/70K-CDRH-449	SPLIT SUCTION	250K/70KBTU	MXK08	57	129	150	295"LX99"W	308"LX102"WX84"H	10316

## HODR - CONFIGURATION TABLE WITH MXK CONDENSERS

MODEL	APPLICATION	DESIGN	COND	REFRIGERANT	MCA	MOPD	BASE FRAME	OVERALL UNIT	WEIGHT ( LBS )
MT-LT-300K/90K-HODR-449	SPLIT SUCTION	300K/90K	MXK08	58	150	175	376" L X 99" W	387" L X 102" W X 70" H	12000
MT-LT-450K/60K-HODR-449	SPLIT SUCTION	450K/60K	MXK10	74	161	175	420" L X 99" W	431" L X 102" W X 70" H	12580
MT-600K-HODR-513	MED TEMP	600K	MXK08	60	225	250	376" L X 99" W	387" L X 102" W X 70" H	12000

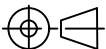
DO NOT SCALE DIMENSIONS TO OUTSIDE UNLESS OTHERWISE NOTED.  
PART TO BE FREE OF BURRS, SHARP EDGES, AND CORNERS

UNLESS OTHERWISE SPECIFIED DIMENSIONS ARE IN INCHES.   THIRD ANGLE PROJECTION	<div style="text-align: right;">  </div> <b>CDRH, MX CONDENSER CONFIG</b>  P/N SUBMITTAL REV. <b>A</b>
SHEET 2 OF 11	

# CDRH UNIT

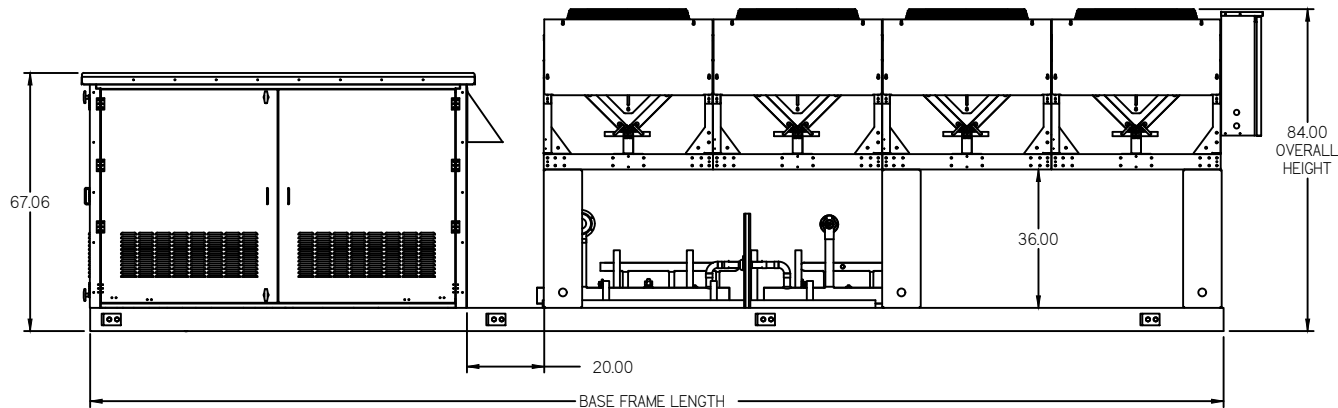
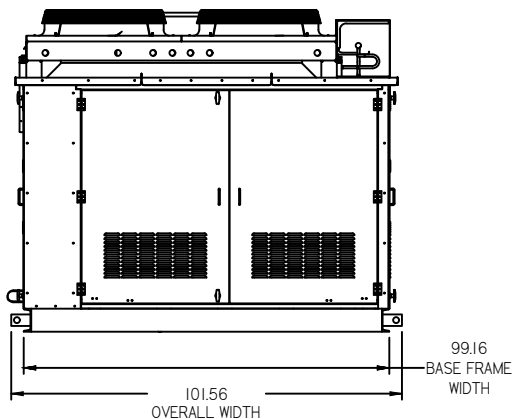
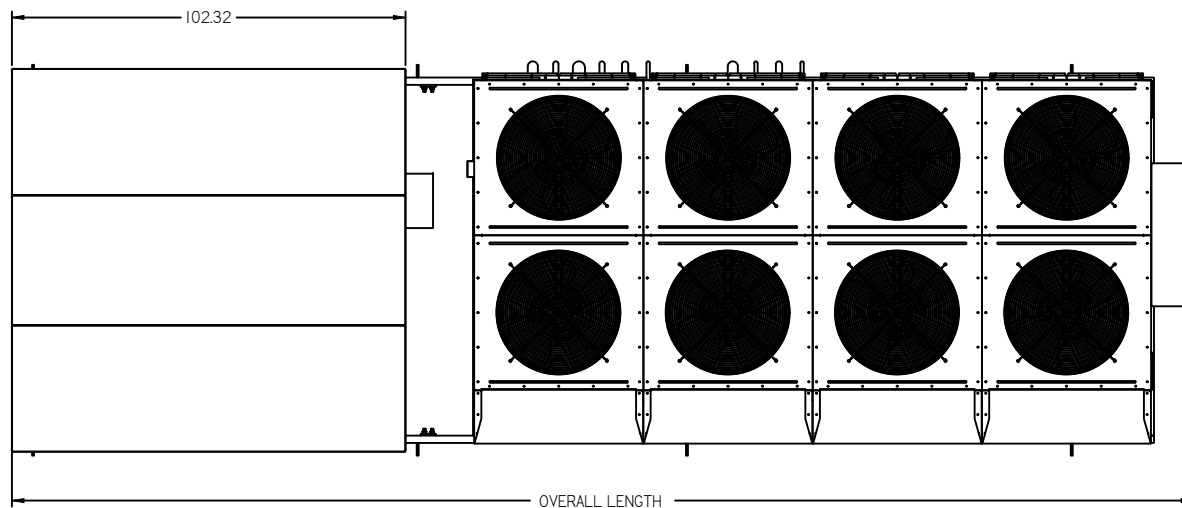

**NOTES:**

1. APPLICABLE STANDARDS / SPECIFICATIONS  
ASME Y14.5M-1994, DIMENSIONS AND TOLERANCES
2. KEY PRODUCT CHARACTERISTICS PER EPR-0006 & IDENTIFIED WITH SYMBOL
3. ALL WELDS PER EPR-1005
4. FRAMES AND WELDMENTS:  
LINEAR DIMENSION TOLERANCE IS  $\pm 125$   
MAXIMUM OUT OF SQUARE IS  $\pm 125$
5. CDRH IN TITLE BLOCK= COMPACT DISTRIBUTED REFRIGERATION UNIT FOR HEB CUSTOMER.
6. IN CASE OF STANDARD CONDENSER WITH VFD ADDITION OVERALL LENGTH & WEIGHT OF UNIT WILL VARY.
7. LARGER TRANSFORMERS WILL BE PLACED UNDERNEATH CONDENSER.
8. MAXIMUM SHIPPING WIDTH OF UNIT, INCLUDING STUB OUT: 102.00".
9. IN CASE OF CONDENSER MOTOR CHANGE UNIT WEIGHT WILL VARY.

UNLESS OTHERWISE SPECIFIED  
DIMENSIONS ARE IN INCHES.

**HUSSmann**<sup>®</sup>

CDRH, MX  
CONDENSER CONFIG

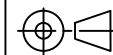

THIRD  
ANGLE  
PROJECTION

SHEET 2 OF 11

PN SUBMITTAL REV A

DO NOT SCALE. DIMENSIONS TO OUTSIDE UNLESS OTHERWISE NOTED.  
PART TO BE FREE OF BURRS, SHARP EDGES, AND CORNERS

SHEET SIZE: 11.0" X 17.0" (A)

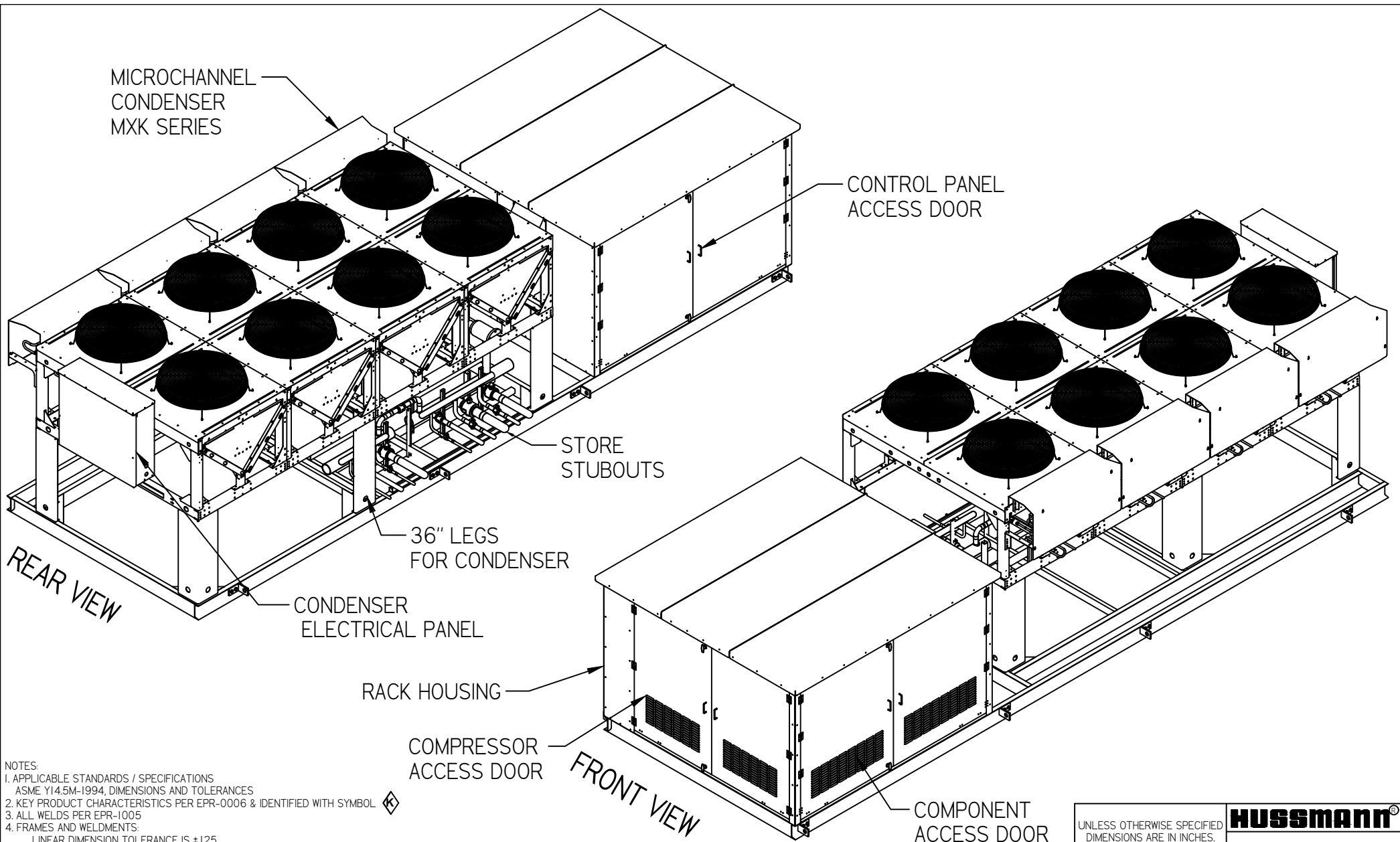

NOTES:

1. APPLICABLE STANDARDS / SPECIFICATIONS  
ASME Y14.5M-1994, DIMENSIONS AND TOLERANCES
2. KEY PRODUCT CHARACTERISTICS PER EPR-0006 & IDENTIFIED WITH SYMBOL  $\diamond$
3. ALL WELDS PER EPR-1005
4. FRAMES AND WELDMENTS:  
LINEAR DIMENSION TOLERANCE IS  $\pm 125$   
MAXIMUM OUT OF SQUARE IS  $\pm 125$
5. CDRH IN TITLE BLOCK= COMPACT DISTRIBUTED REFRIGERATION UNIT FOR HEB CUSTOMER.
6. IN CASE OF STANDARD CONDENSER WITH VFD ADDITION OVERALL LENGTH & WEIGHT OF UNIT WILL VARY.  $\diamond$
7. LARGER TRANSFORMERS WILL BE PLACED UNDERNEATH CONDENSER.
8. MAXIMUM SHIPPING WIDTH OF UNIT, INCLUDING STUB OUT: 102.00 W.  $\diamond$
9. IN CASE OF CONDENSER MOTOR IS CHANGED UNIT WEIGHT WILL VARY.  $\diamond$

DO NOT SCALE. DIMENSIONS TO OUTSIDE UNLESS OTHERWISE NOTED.  
PART TO BE FREE OF BURRS, SHARP EDGES, AND CORNERS

<p>THIRD ANGLE PROJECTION</p>	<p>UNLESS OTHERWISE SPECIFIED DIMENSIONS ARE IN INCHES.</p>		<p><b>HUSSmann</b><sup>®</sup></p>	
	<p>SHEET 3 OF 11</p>		<p>CDRH, MX CONDENSER CONFIG</p>	
<p>PIN SUBMITTAL</p>			<p>REV. A</p>	

PIN 10 - S/W M WELD SHEET SIZE D

# HINGE DOORS OPEN VIEWS

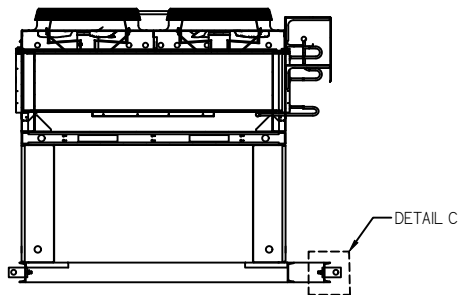

SECTION A-A

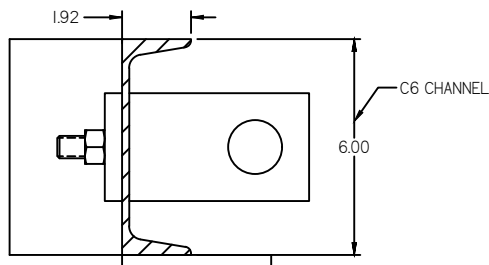

DETAIL C  
CROSS SECTION OF BASE FRAME

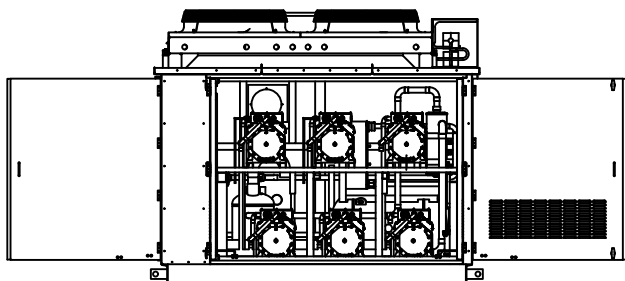

FRONT VIEW

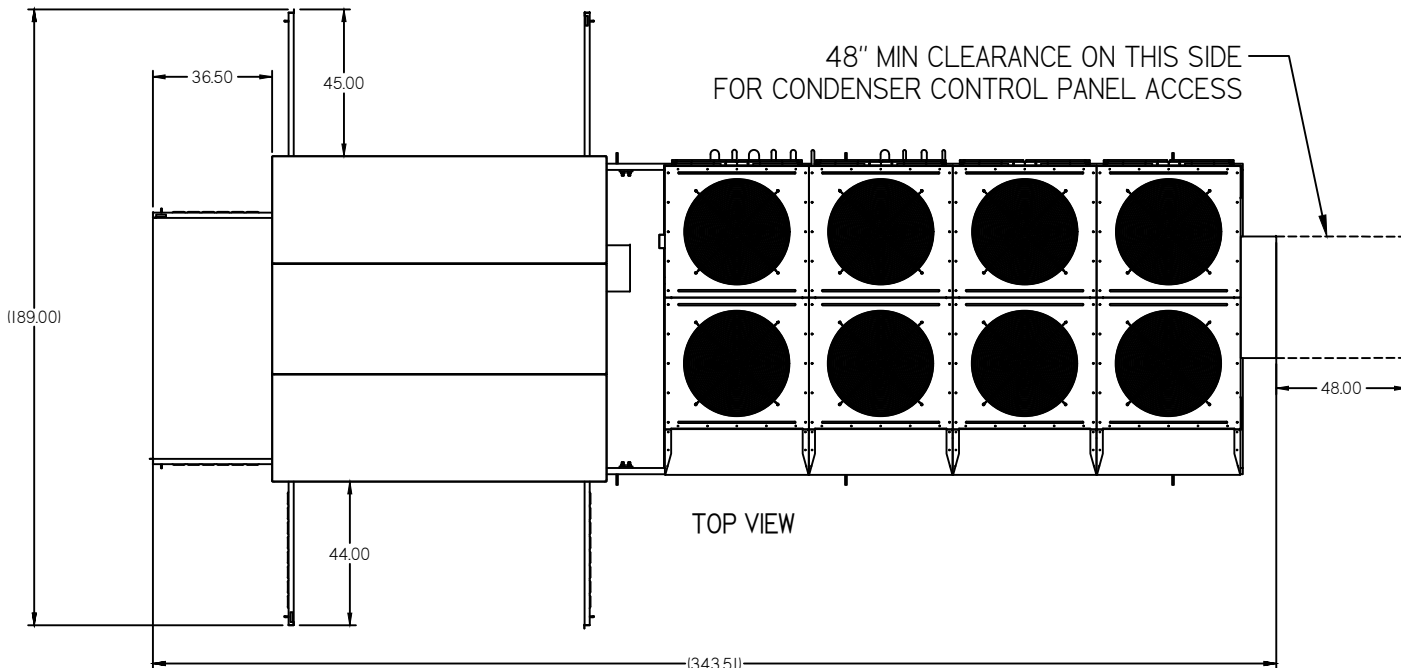

TOP VIEW

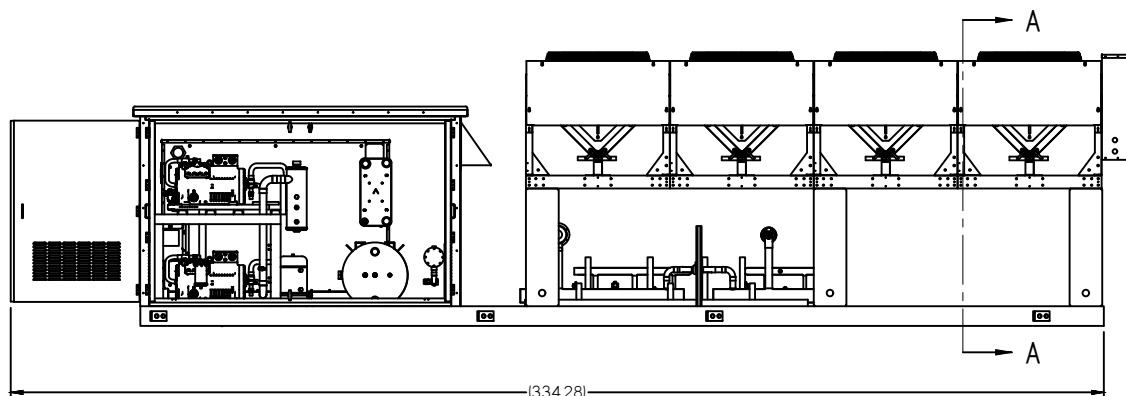

SIDE VIEW

NOTES:

1. APPLICABLE STANDARDS / SPECIFICATIONS  
ASME Y14.5M-1994, DIMENSIONS AND TOLERANCES
2. KEY PRODUCT CHARACTERISTICS PER EPR-0006 & IDENTIFIED WITH SYMBOL
3. ALL WELDS PER EPR-1005
4. FRAMES AND WELDMENTS:  
LINEAR DIMENSION TOLERANCE IS ±.125  
MAXIMUM OUT OF SQUARE IS ±.125
5. CDRH IN TITLE BLOCK= COMPACT DISTRIBUTED REFRIGERATION UNIT FOR HEB CUSTOMER.
6. IN CASE OF STANDARD CONDENSER WITH VFD ADDITION OVERALL LENGTH & WEIGHT OF UNIT WILL VARY.
7. LARGER TRANSFORMERS WILL BE PLACED UNDERNEATH CONDENSER.
8. MAXIMUM SHIPPING WIDTH OF UNIT, INCLUDING STUB OUT: 102.00 W.
9. IN CASE OF CONDENSER MOTOR IS CHANGED UNIT WEIGHT WILL VARY.

DO NOT SCALE. DIMENSIONS TO OUTSIDE UNLESS OTHERWISE NOTED.  
PART TO BE FREE OF BURRS, SHARP EDGES, AND CORNERS

UNLESS OTHERWISE SPECIFIED DIMENSIONS ARE IN INCHES.  THIRD ANGLE PROJECTION	<b>HUSSMANN</b> ®	
	CDRH, MX CONDENSER CONFIG	
SHEET 4 OF 11	P/N SUBMITTAL	REV. A

SHEET 4 OF 11 - WELD SHEET SIZE D

HINGE DOORS OPEN VIEWS

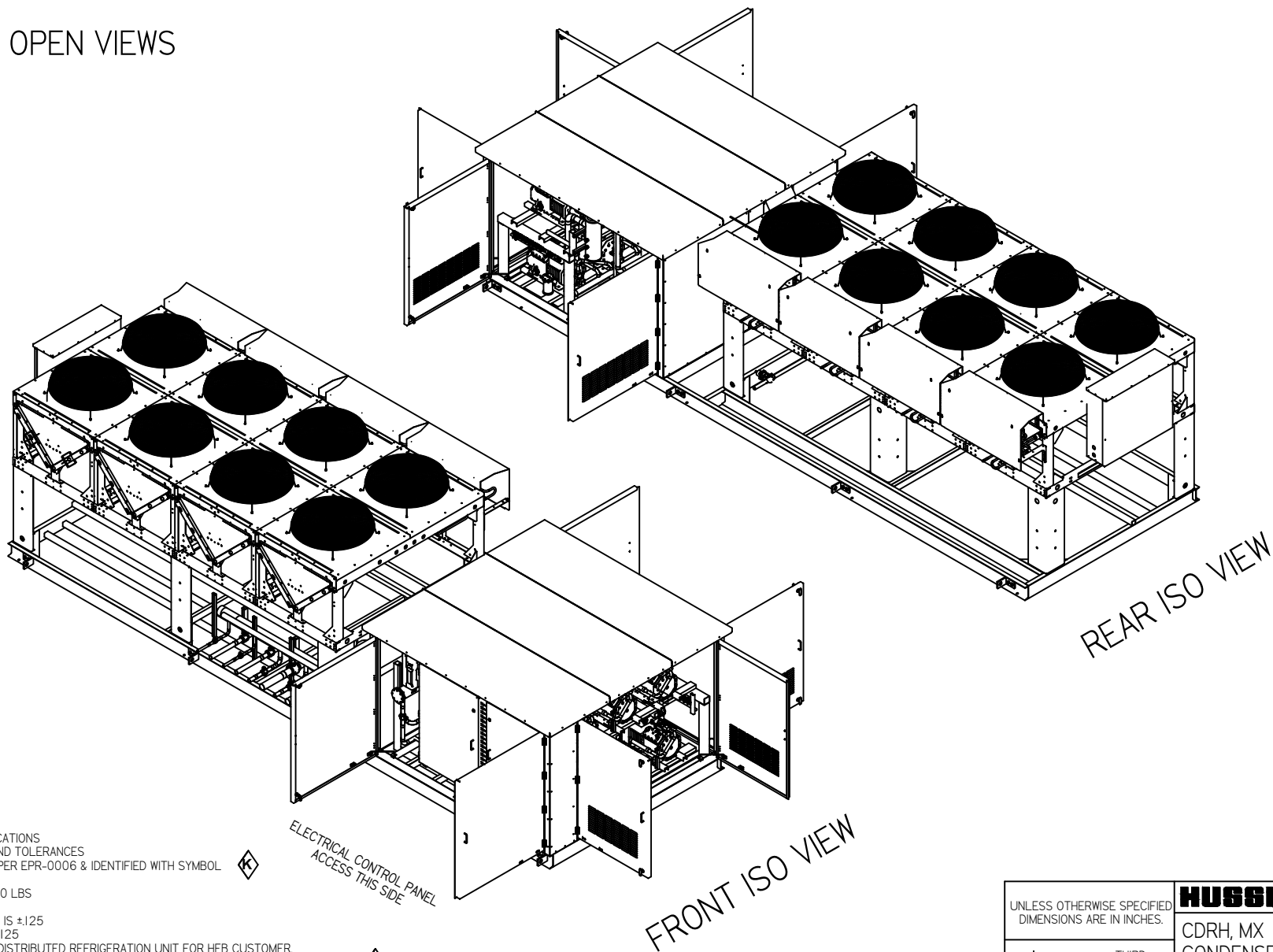

REAR ISO VIEW

FRONT ISO VIEW

ELECTRICAL CONTROL PANEL  
ACCESS THIS SIDE

NOTES:

1. APPLICABLE STANDARDS / SPECIFICATIONS  
ASME Y14.5M-1994, DIMENSIONS AND TOLERANCES
2. KEY PRODUCT CHARACTERISTICS PER EPR-0006 & IDENTIFIED WITH SYMBOL
3. ALL WELDS PER EPR-1005
4. APPROX WEIGHT OF THE UNIT - 9000 LBS
5. FRAMES AND WELDMENTS:  
LINEAR DIMENSION TOLERANCE IS  $\pm 125$   
MAXIMUM OUT OF SQUARE IS  $\pm 125$
6. CDRH IN TITLE BLOCK= COMPACT DISTRIBUTED REFRIGERATION UNIT FOR HEB CUSTOMER
7. IN CASE OF STANDARD CONDENSER WITH VFD ADDITION OVERALL LENGTH & WEIGHT OF UNIT WILL VARY.
8. LARGER TRANSFORMERS WILL BE PLACED UNDERNEATH CONDENSER.
9. MAXIMUM SHIPPING WIDTH OF UNIT, INCLUDING STUB OUT: 102.00".
10. IN CASE OF CONDENSER MOTOR CHANGE UNIT WEIGHT WILL VARY.

UNLESS OTHERWISE SPECIFIED DIMENSIONS ARE IN INCHES.  THIRD ANGLE PROJECTION	<b>HUSSmann</b> <sup>®</sup>	
	CDRH, MX CONDENSER CONFIG	
SHEET 5 OF 11	P/N SUBMITTAL	REV. A

DO NOT SCALE. DIMENSIONS TO OUTSIDE UNLESS OTHERWISE NOTED.  
PART TO BE FREE OF BURRS, SHARP EDGES, AND CORNERS

SHEET SIZE: 36" X 48" WELD SHEET SIZE D

# RIGGING FOR ILLUSTRATION ONLY

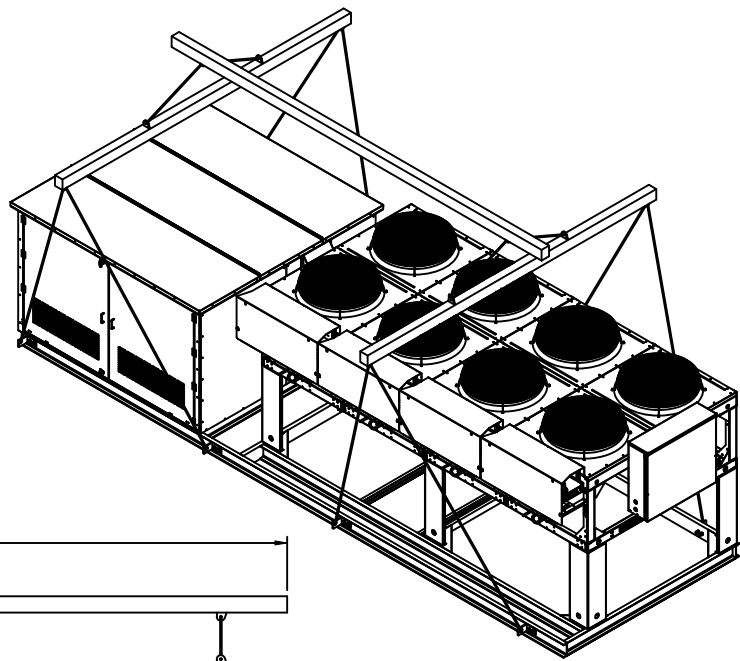
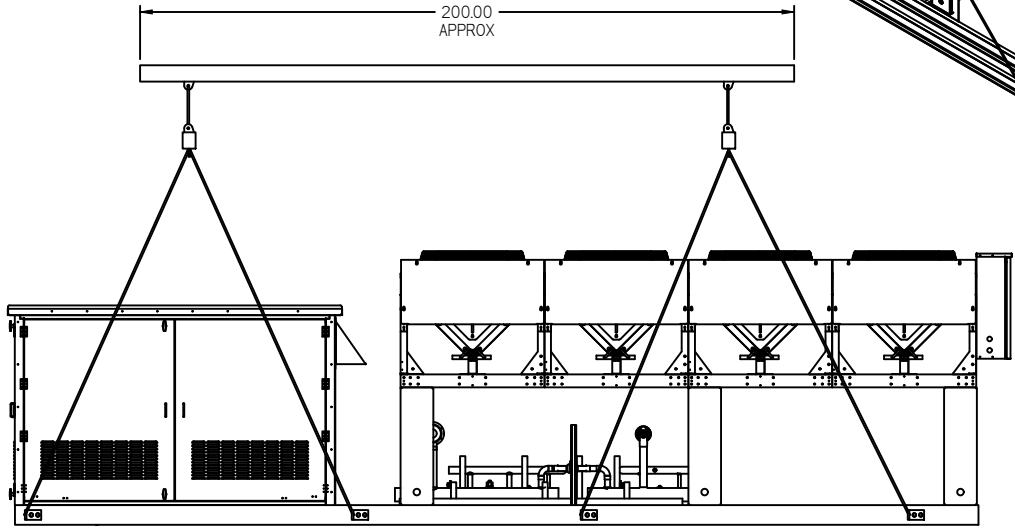
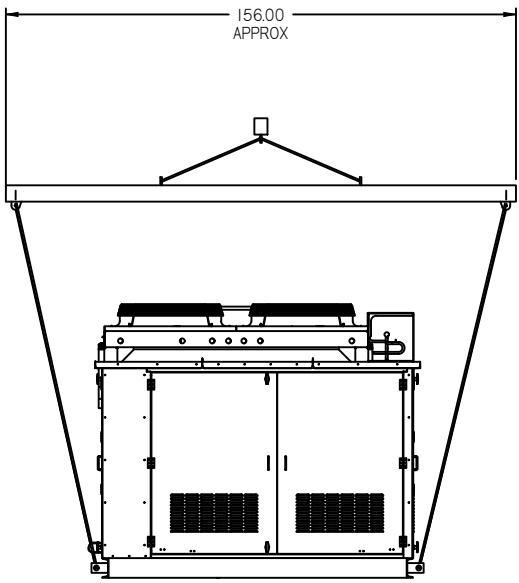

NOTES:

1. APPLICABLE STANDARDS / SPECIFICATIONS  
ASME Y14.5M-1994, DIMENSIONS AND TOLERANCES
2. KEY PRODUCT CHARACTERISTICS PER EPR-0006 & IDENTIFIED WITH SYMBOL
3. ALL WELDS PER EPR-1005
4. FRAMES AND WELDMENTS:  
LINEAR DIMENSION TOLERANCE IS ±.125  
MAXIMUM OUT OF SQUARE IS ±.125
5. CDRH IN TITLE BLOCK= COMPACT DISTRIBUTED REFRIGERATION UNIT FOR HEB CUSTOMER.
6. IN CASE OF STANDARD CONDENSER WITH VFD ADDITION OVERALL LENGTH & WEIGHT OF UNIT WILL VARY.
7. LARGER TRANSFORMERS WILL BE PLACED UNDERNEATH CONDENSER.
8. MAXIMUM SHIPPING WIDTH OF UNIT, INCLUDING STUB OUT: 102.00 W.
9. IN CASE OF CONDENSER MOTOR IS CHANGED UNIT WEIGHT WILL VARY.

DO NOT SCALE. DIMENSIONS TO OUTSIDE UNLESS OTHERWISE NOTED.  
PART TO BE FREE OF BURRS, SHARP EDGES, AND CORNERS

UNLESS OTHERWISE SPECIFIED DIMENSIONS ARE IN INCHES.	<b>HUSSMANN</b> <sup>®</sup>
THIRD ANGLE PROJECTION	CDRH, MX CONDENSER CONFIG
SHEET 6 OF 11	P/N SUBMITTAL REV. A

SHEET 6 OF 11

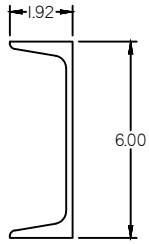

C6-BASE PROFILE

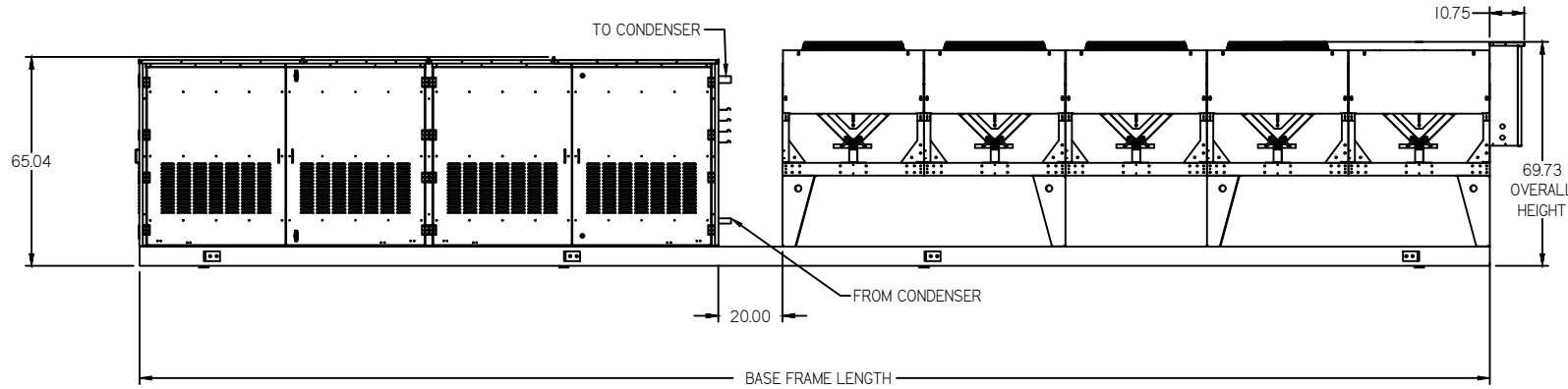
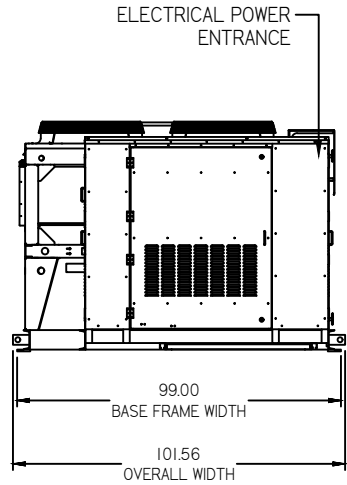
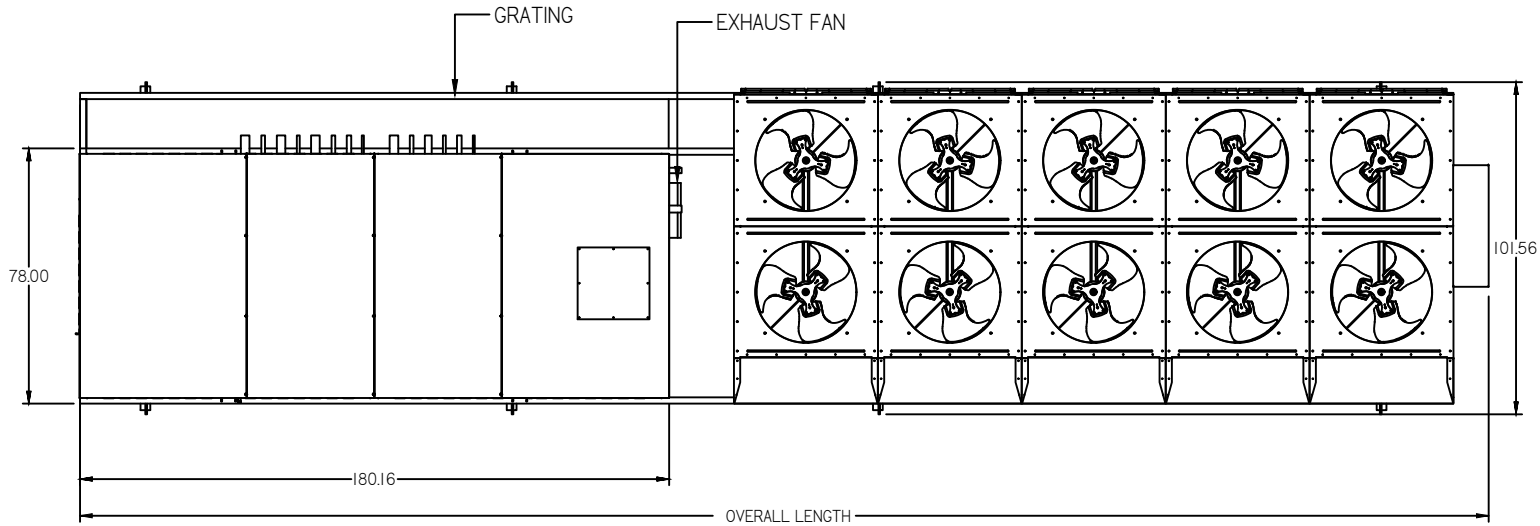

NOTES:

1. APPLICABLE STANDARDS / SPECIFICATIONS  
ASME Y14.5M-1994, DIMENSIONS AND TOLERANCES
2. KEY PRODUCT CHARACTERISTICS PER EPR-0006 & IDENTIFIED WITH SYMBOL
3. ALL WELDS PER EPR-1005
4. FRAMES AND WELDMENTS:  
LINEAR DIMENSION TOLERANCE IS ±.125  
MAXIMUM OUT OF SQUARE IS ±.125
5. IN CASE OF STANDARD CONDENSER WITH VFD ADDITION, OVERALL LENGTH & WEIGHT OF UNIT WILL VARY.
6. LARGER TRANSFORMER WILL BE PLACED UNDERNEATH CONDENSER.
7. MAXIMUM SHIPPING WIDTH OF UNIT, INCLUDING STUB OUT: 102.00 W
8. LIFTING LUGS ARE BOLTED
9. HODR IN TITLE BLOCK= HEB OUT DOOR RACK

DO NOT SCALE. DIMENSIONS TO OUTSIDE UNLESS OTHERWISE NOTED.  
PART TO BE FREE OF BURRS, SHARP EDGES, AND CORNERS

UNLESS OTHERWISE SPECIFIED DIMENSIONS ARE IN INCHES.	<b>HUSSMANN</b>	
	HODR-006SP MODULAR UNIT	
THIRD ANGLE PROJECTION	PIN	REV
SHEET 7 OF 11	SUBMITTAL A	

SWN 10 - SWE WELD SHEET SIZE D

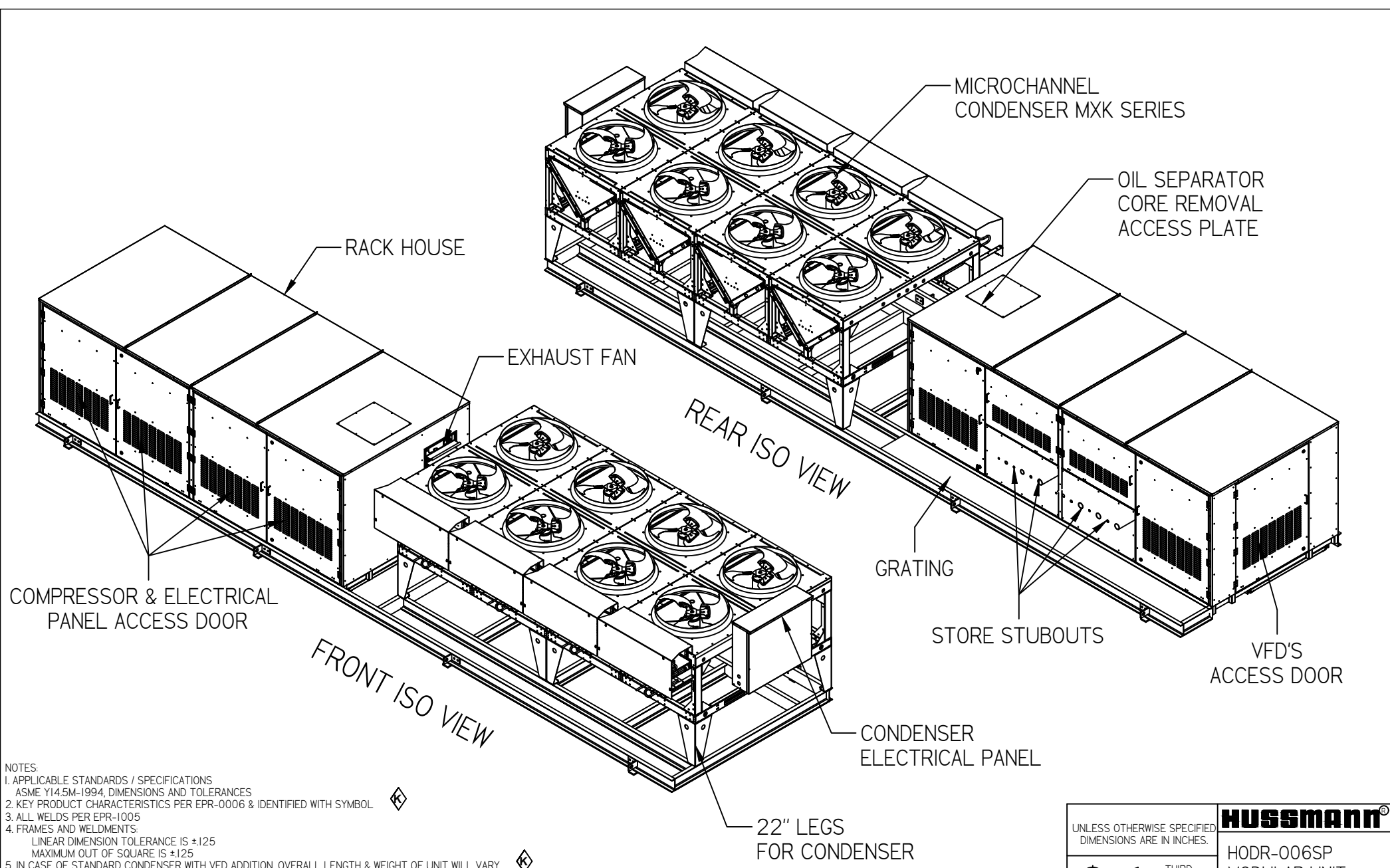

NOTES:

1. APPLICABLE STANDARDS / SPECIFICATIONS  
ASME Y14.5M-1994, DIMENSIONS AND TOLERANCES
2. KEY PRODUCT CHARACTERISTICS PER EPR-0006 & IDENTIFIED WITH SYMBOL
3. ALL WELDS PER EPR-1005
4. FRAMES AND WELDMENTS:  
LINEAR DIMENSION TOLERANCE IS  $\pm 1.25$   
MAXIMUM OUT OF SQUARE IS  $\pm 1.25$
5. IN CASE OF STANDARD CONDENSER WITH VFD ADDITION, OVERALL LENGTH & WEIGHT OF UNIT WILL VARY.
6. LARGER TRANSFORMER WILL BE PLACED UNDERNEATH CONDENSER.
7. MAXIMUM SHIPPING WIDTH OF UNIT, INCLUDING STUB OUT: 102.00 W
8. LIFTING LUGS ARE BOLTED
9. HODR IN TITLE BLOCK = HEB OUT DOOR RACK

DO NOT SCALE. DIMENSIONS TO OUTSIDE UNLESS OTHERWISE NOTED.  
PART TO BE FREE OF BURRS, SHARP EDGES, AND CORNERS

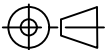
UNLESS OTHERWISE SPECIFIED DIMENSIONS ARE IN INCHES.		<b>HUSSMANN</b>	
 THIRD ANGLE PROJECTION		HODR-006SP MODULAR UNIT	
		PIN SUBMITTAL	REV. A
SHEET 8 OF 11			

SHEET 8 OF 11



# HINGE DOORS OPEN VIEWS

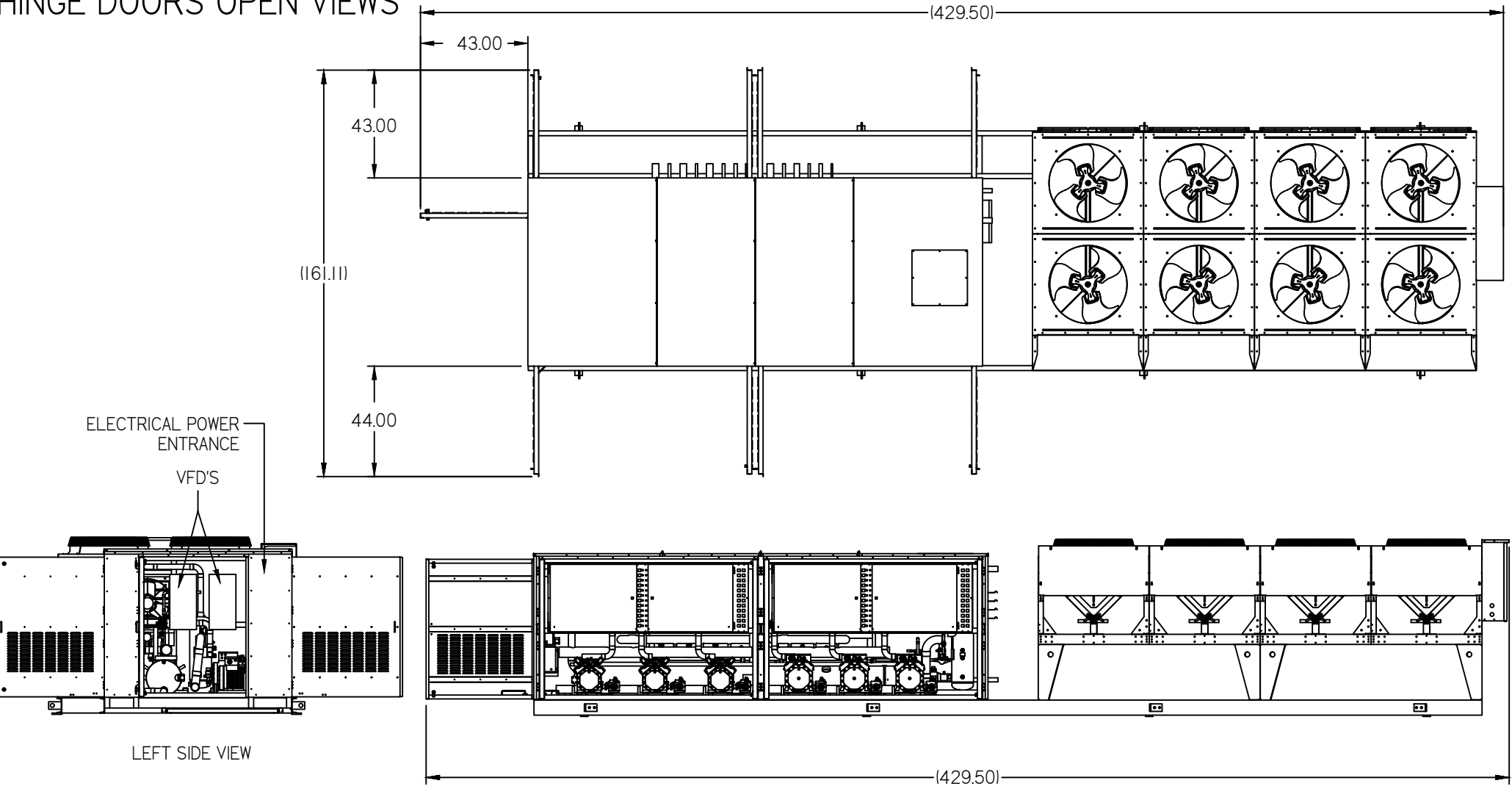

- NOTES:
1. APPLICABLE STANDARDS / SPECIFICATIONS  
ASME Y14.5M-1994, DIMENSIONS AND TOLERANCES
  2. KEY PRODUCT CHARACTERISTICS PER EPR-0006 & IDENTIFIED WITH SYMBOL
  3. ALL WELDS PER EPR-1005
  4. FRAMES AND WELDMENTS:  
LINEAR DIMENSION TOLERANCE IS ±.125  
MAXIMUM OUT OF SQUARE IS ±.125
  5. IN CASE OF STANDARD CONDENSER WITH VFD ADDITION, OVERALL LENGTH & WEIGHT OF UNIT WILL VARY.
  6. LARGER TRANSFORMER WILL BE PLACED UNDERNEATH CONDENSER.
  7. MAXIMUM SHIPPING WIDTH OF UNIT, INCLUDING STUB OUT: 102.00 W
  8. LIFTING LUGS ARE BOLTED
  9. HODR IN TITLE BLOCK= HEB OUT DOOR RACK

DO NOT SCALE. DIMENSIONS TO OUTSIDE UNLESS OTHERWISE NOTED.  
PART TO BE FREE OF BURRS, SHARP EDGES, AND CORNERS

UNLESS OTHERWISE SPECIFIED DIMENSIONS ARE IN INCHES.		<b>HUSSMANN</b>	
 THIRD ANGLE PROJECTION		HODR-006SP MODULAR UNIT	
		P/N SUBMITTAL REV. A	
SHEET 9 OF 11			

S/N 10 - S/W E WELD SHEET SIZE D

# HINGE DOORS OPEN VIEWS

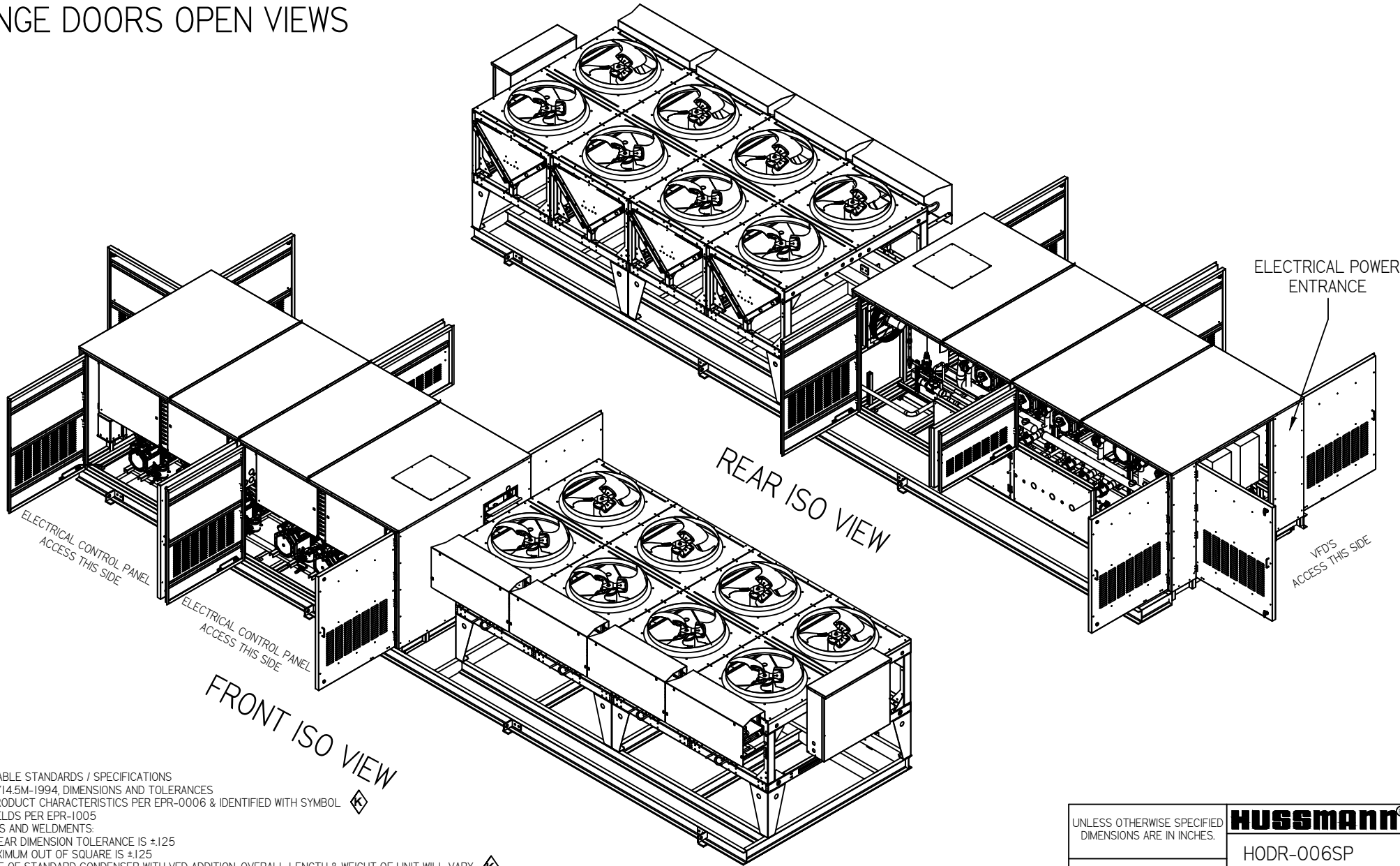

**NOTES:**

1. APPLICABLE STANDARDS / SPECIFICATIONS  
ASME Y14.5M-1994, DIMENSIONS AND TOLERANCES
2. KEY PRODUCT CHARACTERISTICS PER EPR-0006 & IDENTIFIED WITH SYMBOL  $\diamond$
3. ALL WELDS PER EPR-1005
4. FRAMES AND WELDMENTS:  
LINEAR DIMENSION TOLERANCE IS  $\pm 125$   
MAXIMUM OUT OF SQUARE IS  $\pm 125$
5. IN CASE OF STANDARD CONDENSER WITH VFD ADDITION, OVERALL LENGTH & WEIGHT OF UNIT WILL VARY.  $\diamond$
6. LARGER TRANSFORMER WILL BE PLACED UNDERNEATH CONDENSER.
7. MAXIMUM SHIPPING WIDTH OF UNIT, INCLUDING STUB OUT: 102.00 W  $\diamond$
8. LIFTING LUGS ARE BOLTED
9. HODR IN TITLE BLOCK= HEB OUT DOOR RACK

DO NOT SCALE. DIMENSIONS TO OUTSIDE UNLESS OTHERWISE NOTED.  
PART TO BE FREE OF BURRS, SHARP EDGES, AND CORNERS

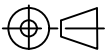
 THIRD ANGLE PROJECTION	UNLESS OTHERWISE SPECIFIED DIMENSIONS ARE IN INCHES.		<b>HUSSmann</b>	
	HODR-006SP MODULAR UNIT		PIN SUBMITTAL REV A	
SHEET 10 OF 11		SWS 10 - SWS WELD SHEET SIZE D		

# RIGGING FOR ILLUSTRATION ONLY

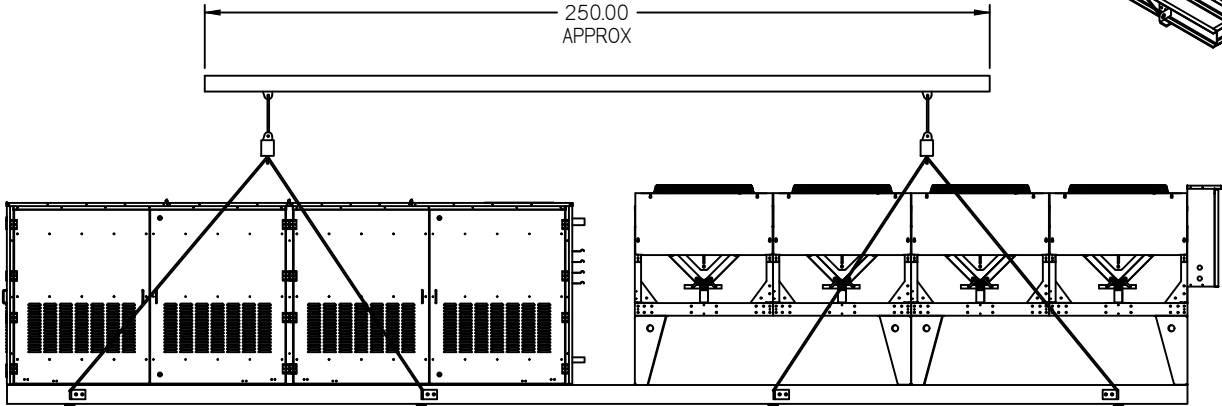
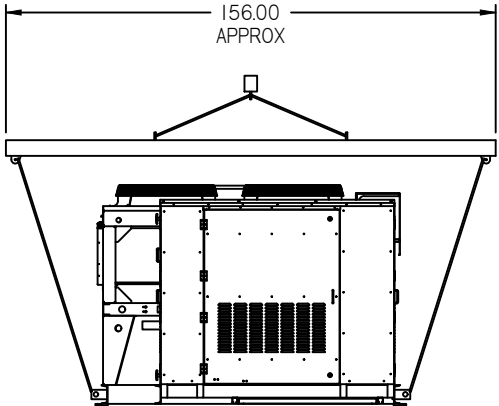
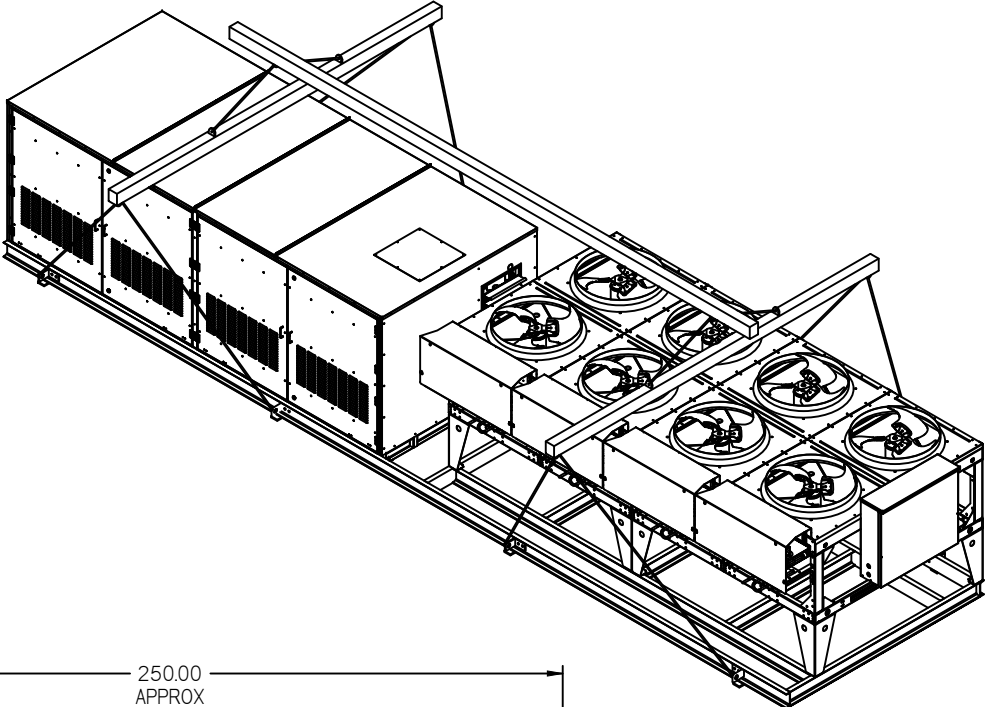

- NOTES:
1. APPLICABLE STANDARDS / SPECIFICATIONS  
ASME Y14.5M-1994, DIMENSIONS AND TOLERANCES
  2. KEY PRODUCT CHARACTERISTICS PER EPR-0006 & IDENTIFIED WITH SYMBOL
  3. ALL WELDS PER EPR-1005
  4. FRAMES AND WELDMENTS:  
LINEAR DIMENSION TOLERANCE IS  $\pm 0.125$   
MAXIMUM OUT OF SQUARE IS  $\pm 0.125$
  5. IN CASE OF STANDARD CONDENSER WITH VFD ADDITION, OVERALL LENGTH & WEIGHT OF UNIT WILL VARY.
  6. LARGER TRANSFORMER WILL BE PLACED UNDERNEATH CONDENSER
  7. MAXIMUM SHIPPING WIDTH OF UNIT, INCLUDING STUB OUT: 102.00 W
  8. LIFTING LUGS ARE BOLTED
  9. HDR IN TITLE BLOCK= HEB OUT DOOR RACK

DO NOT SCALE. DIMENSIONS TO OUTSIDE UNLESS OTHERWISE NOTED.  
PART TO BE FREE OF BURRS, SHARP EDGES, AND CORNERS

	UNLESS OTHERWISE SPECIFIED DIMENSIONS ARE IN INCHES.	<b>HUSSmann</b>	
		HODR-006SP MODULAR UNIT	
		SHEET 11 OF 11	SUBMITTAL
			REV. A

SWN 10 - SWNE WELD SHEET SIZE D