

MINIMUM CLEARANCE REQUIREMENTS:

ACTUAL CLEARANCE REQUIREMENTS ARE DEPENDENT UPON AUTHORITY HAVING JURISDICTION, AND MAY EXCEED DIMENSION SHOWN.

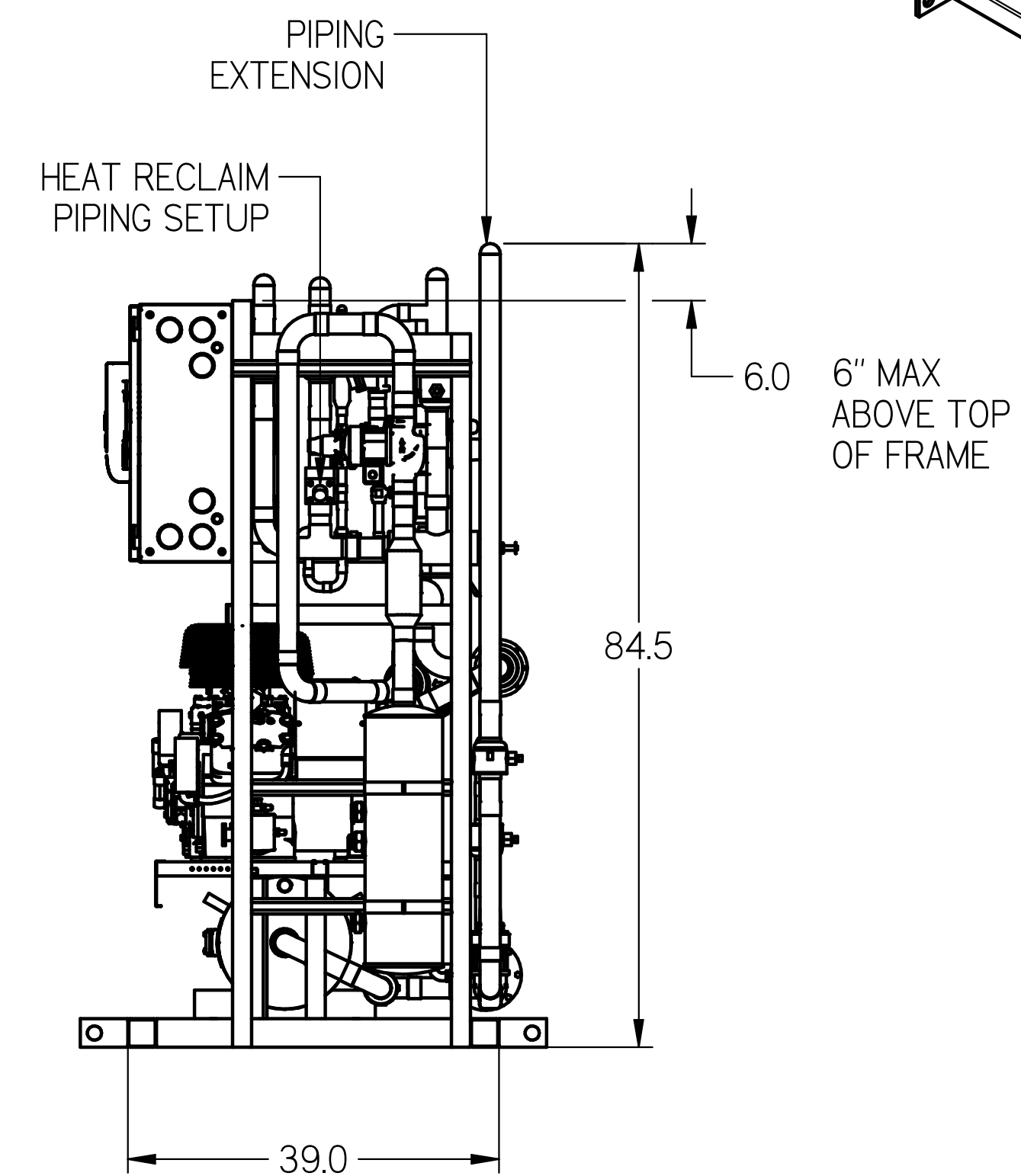
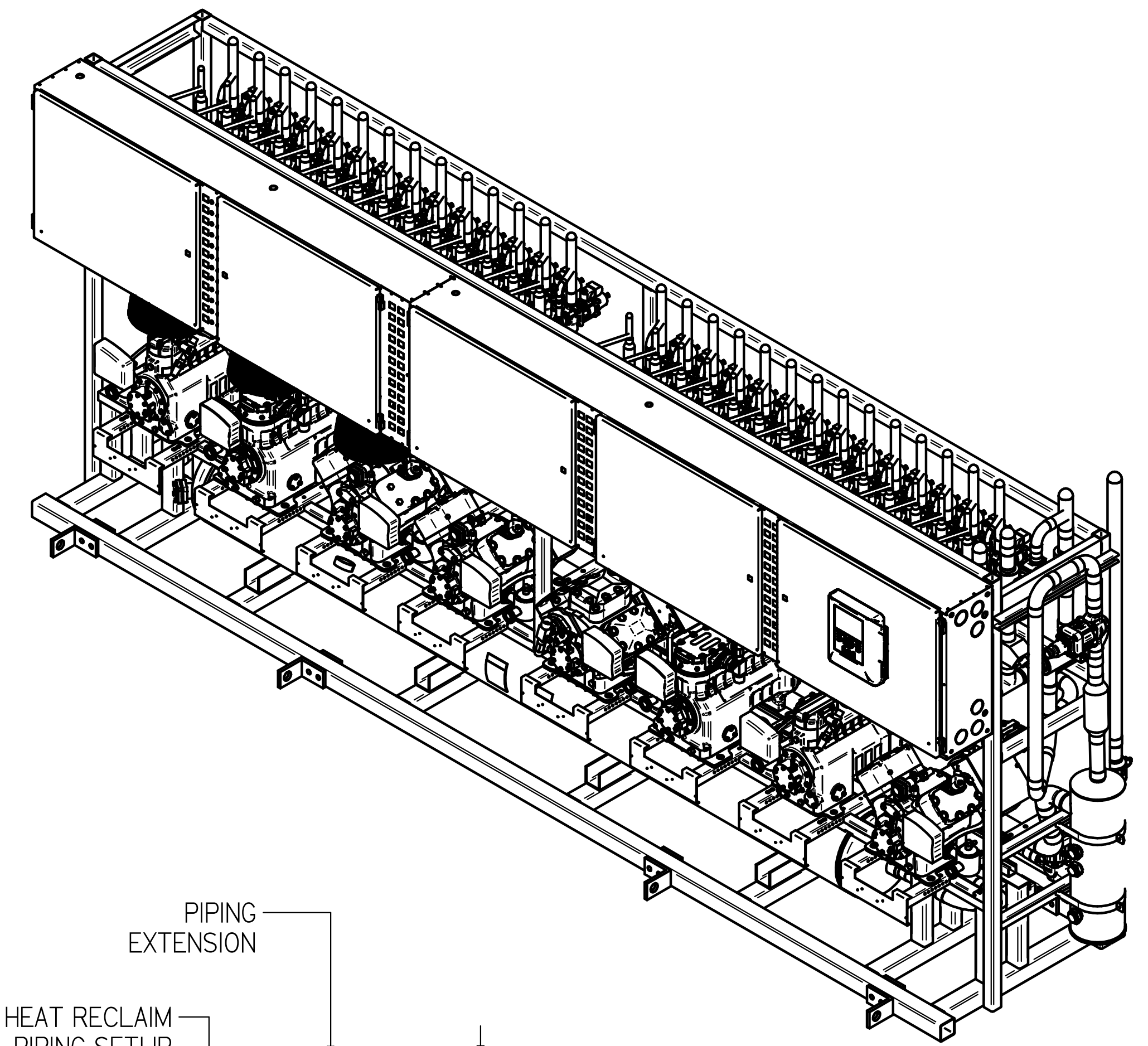
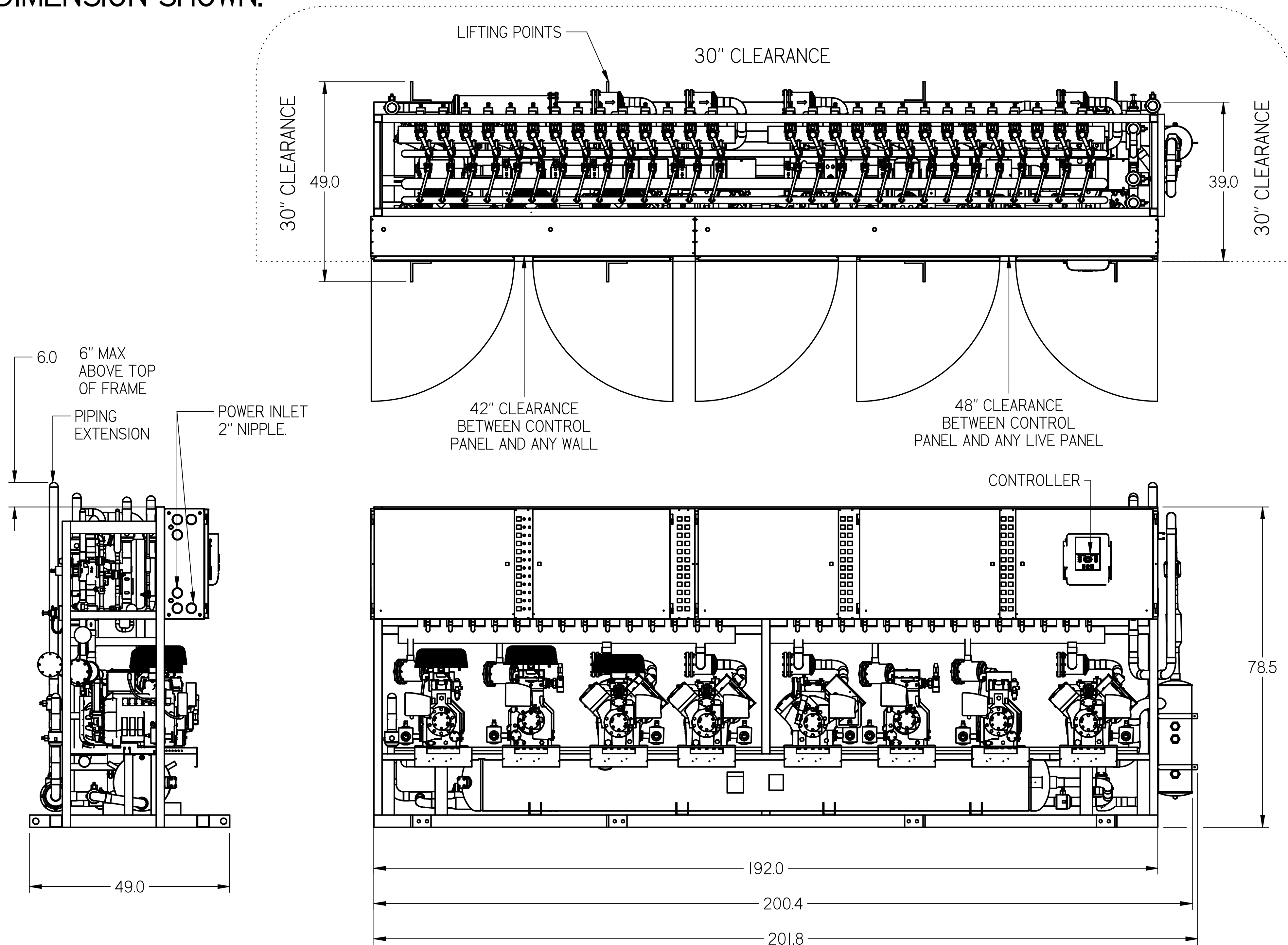

RACK DIMENSIONS: 200"L X 39"W X 78.5"H

MAXIMUM TOTAL UNIT WEIGHT(LBS)	
SHIPPING	OPERATING
6232	6870

DIMENSIONS ARE IN INCHES.
DATE DRAWN: 2017/09/14

THIRD ANGLE PROJECTION

SHEET 1 OF 3

HUSSMANN[®]

8CRH-PARALLEL
RACK INDOOR

DOC PD-000000040 REV B

NOTES:

- IT IS THE RESPONSIBILITY OF THE INSTALLING CONTRACTOR TO ENSURE THAT THE FINAL EQUIPMENT INSTALLATION MEETS ALL APPLICABLE CODE REQUIREMENTS.
- ILLUSTRATION SHOWN IS FOR GENERAL REPRESENTATION ONLY. ACTUAL PRODUCT WILL VARY DEPENDENT UPON APPLICATION.
- OVERALL DIMENSIONS: 201.8 L X 49.0 W X 84.5 H.
- RECEIVER SIZES SHOWN ARE BASED UPON 80% CAPACITY.

INFORMATION SUBJECT TO CHANGE

SWN 1.0 SUBMITTAL SHEET SIZE D

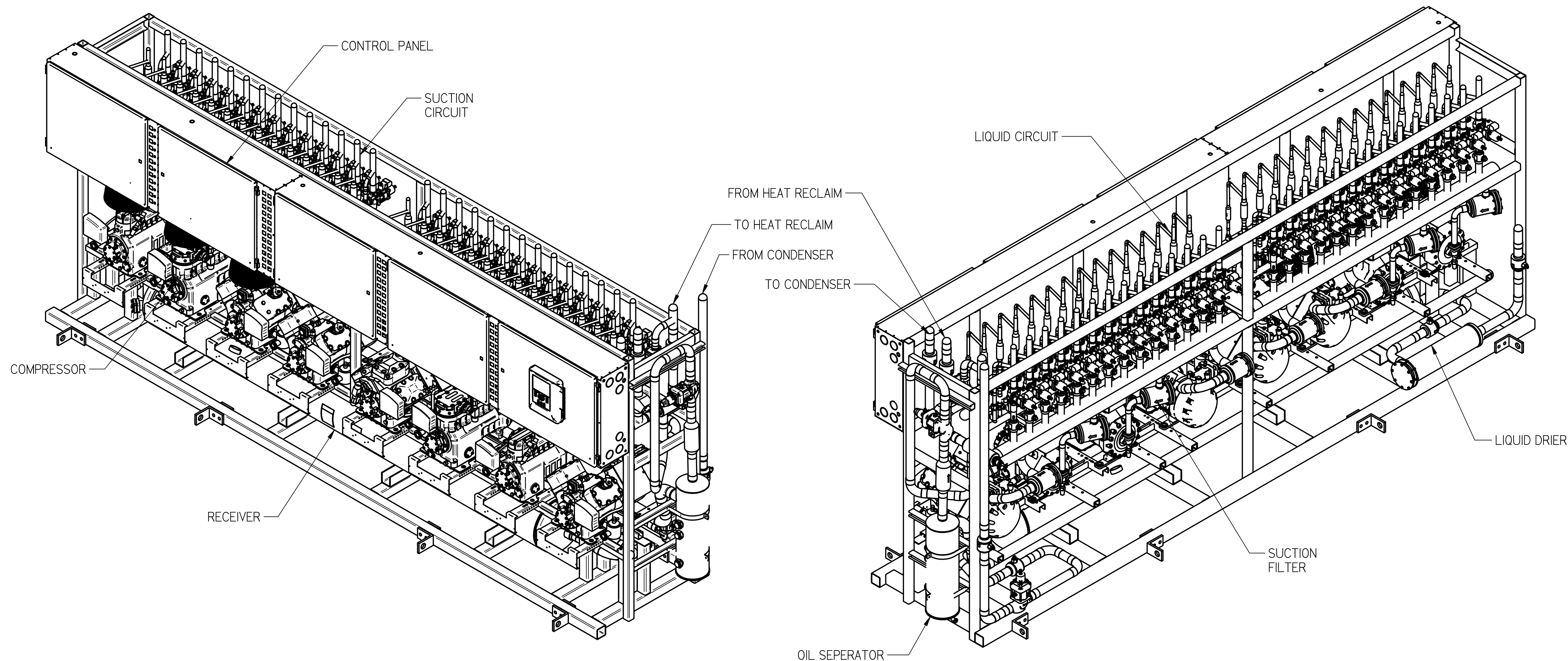

NOTES:

1. IT IS THE RESPONSIBILITY OF THE INSTALLING CONTRACTOR TO ENSURE THAT THE FINAL EQUIPMENT INSTALLATION MEETS ALL APPLICABLE CODE REQUIREMENTS.
2. ILLUSTRATION SHOWN IS FOR GENERAL REPRESENTATION ONLY. ACTUAL PRODUCT WILL VARY DEPENDENT UPON APPLICATION.
3. OVERALL DIMENSIONS: 201.8 L X 49.0 W X 84.5 H.
4. RECEIVER SIZES SHOWN ARE BASED UPON 80% CAPACITY.

INFORMATION SUBJECT TO CHANGE

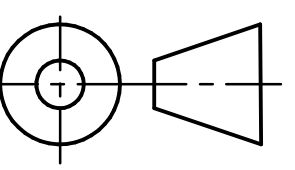
DIMENSIONS ARE IN INCHES. DATE DRAWN: 2017/09/14		HUSSMANN [®]	
 THIRD ANGLE PROJECTION		8CRH-PARALLEL RACK INDOOR	
		DOC PD-000000040	REV B
SHEET 2 OF 3			

SHEET 2 OF 3

RIGGING DETAILS

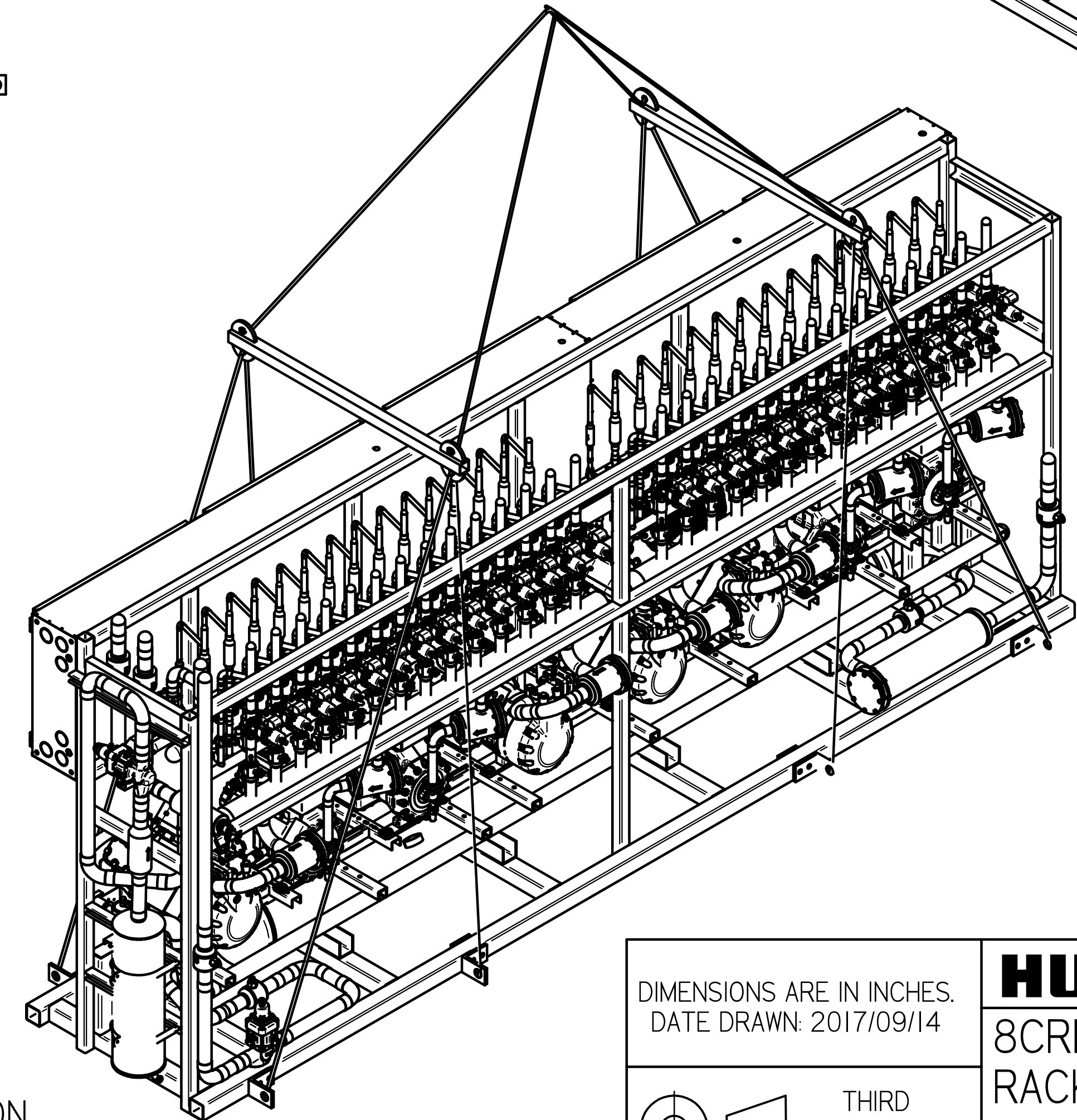
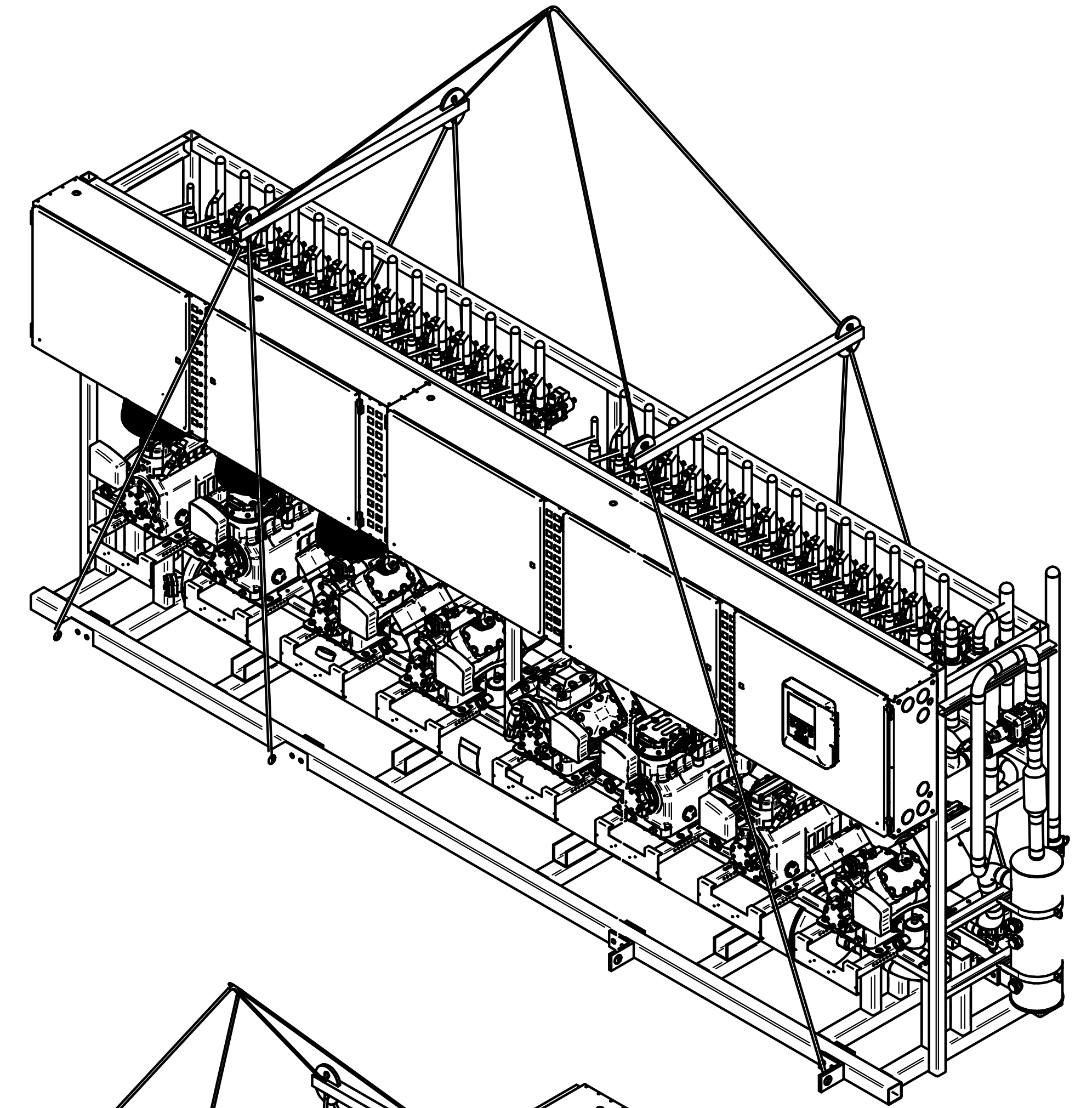
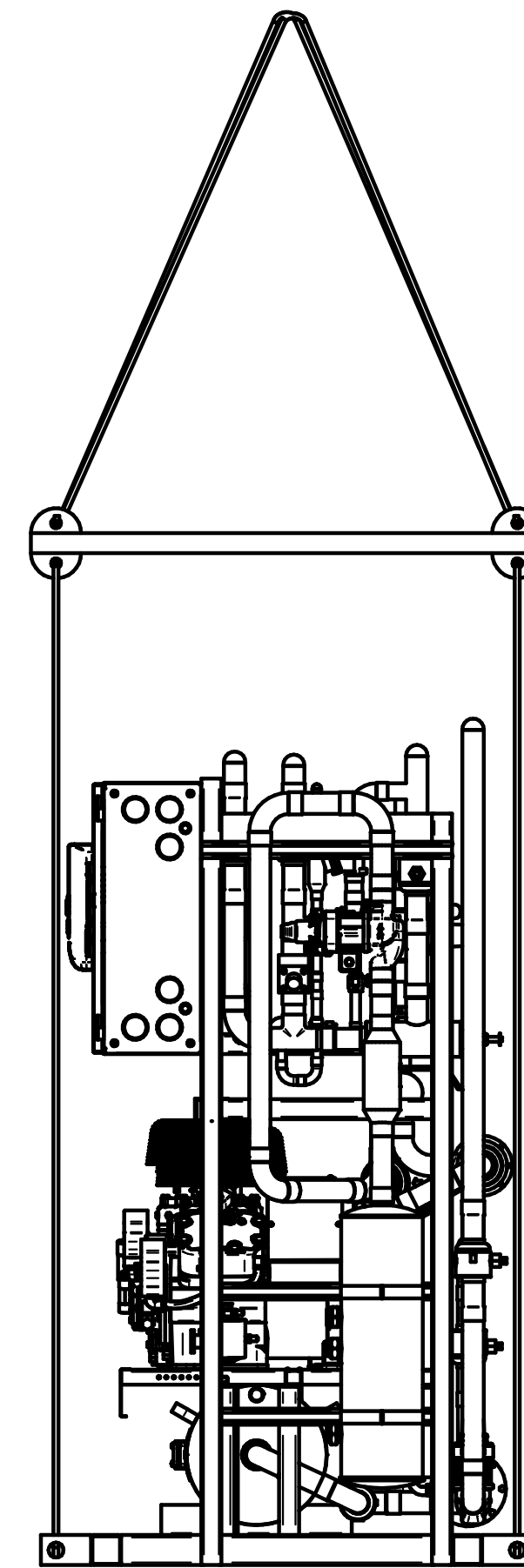
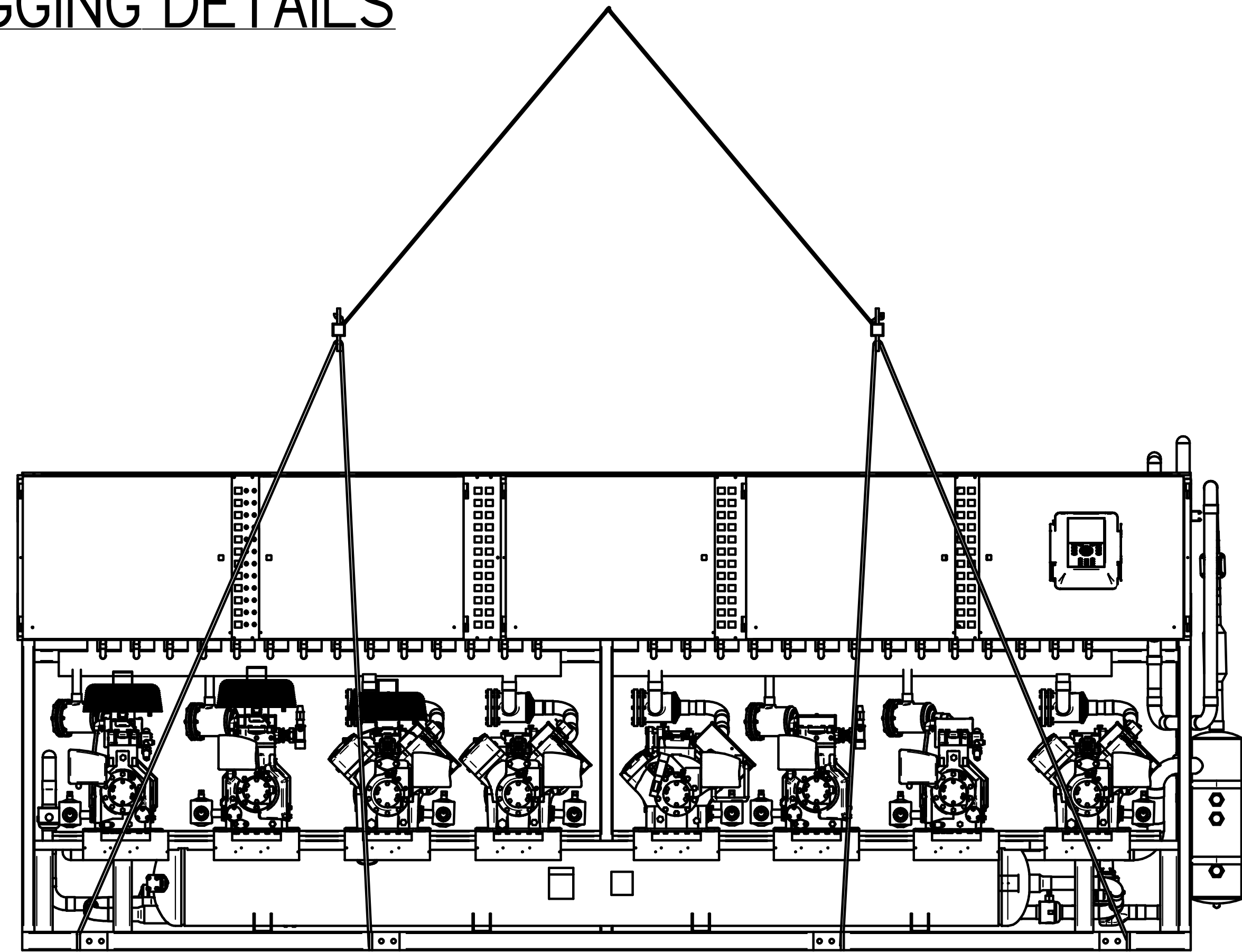

NOTES FOR RIGGING:
THE RIGGING ILLUSTRATION SHOWN IS FOR GENERAL REPRESENTATION ONLY.
ACTUAL RIGGING MAY VARY PER APPLICATION.

- NOTES:
1. IT IS THE RESPONSIBILITY OF THE INSTALLING CONTRACTOR TO ENSURE THAT THE FINAL EQUIPMENT INSTALLATION MEETS ALL APPLICABLE CODE REQUIREMENTS.
 2. ILLUSTRATION SHOWN IS FOR GENERAL REPRESENTATION ONLY. ACTUAL PRODUCT WILL VARY DEPENDENT UPON APPLICATION.
 3. OVERALL DIMENSIONS: 201.8 L X 49.0 W X 84.5 H.
 4. RECEIVER SIZES SHOWN ARE BASED UPON 80% CAPACITY.

INFORMATION SUBJECT TO CHANGE

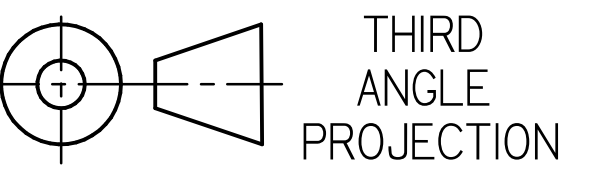
DIMENSIONS ARE IN INCHES. DATE DRAWN: 2017/09/14		HUSSMANN [®]	
 THIRD ANGLE PROJECTION		8CRH-PARALLEL RACK INDOOR	
		DOC PD-000000040	REV B
SHEET 3 OF 3			

SWN 1.0 SUBMITTAL SHEET SIZE D