

HUSSMANN®



microDS™

WARNINGS:

If the information in these instructions are not followed exactly, a fire or explosion may result, causing property damage, personal injury or death.

Installation and service must be performed by a qualified installer or service agency.

READ THE ENTIRE MANUAL BEFORE INSTALLING OR USING THIS EQUIPMENT.

The unit uses R-290 (propane) gas as the refrigerant. R-290 (propane) is flammable and heavier than air. It collects first in low areas but can be circulated by the fans. If propane gas is present or even suspected, do not allow untrained personnel to attempt to find the cause. The propane gas used in the unit has no odor. The lack of smell does not indicate a lack of escaped gas. If a leak is detected, immediately evacuate all persons from the store, and contact the local fire department to advise them that a propane leak has occurred. Do not let any persons back into the store until the qualified service technician has arrived and that technician advises that it is safe to return to the store. No open flames, cigarettes or other possible sources of ignition should be used inside or in the vicinity of the units.

FAILURE TO ABIDE BY THIS WARNING COULD RESULT IN AN EXPLOSION, DEATH, INJURY AND PROPERTY DAMAGE.

Use this manual along with door manual P/N 0425683 for cases with Innovator Doors

IMPORTANT!
Keep in store for future reference!

MANUAL - MDS LOW TEMP IO

Micro-Distributed Reach-In Merchandisers with R-290 (Propane) Refrigerant



This manual applies to the following case models:

RL2W - RL5W
RLN2W - RLN5W
RLNI4W - RLNI5W
RL2SP - RL5SP
RLN2SP - RLN5SP
RLNI5SP - RLNI5SP
RM2W - RM5W
RMN2W - RMN5W

For clarity in the documentation, all illustrations use the RL, RLN, and RLNI nomenclatures for reference.

Installation & Operation Manual Shipped With Case Data Sheets

P/N 3053328_D
December 2019

Spanish P/N 3053329
French P/N 3053330

 **WARNING**

This equipment uses a flammable refrigerant. Installation, service and repair should be done only by qualified and trained technicians in accordance with this manual.

If a leak is detected, follow store safety procedures. It is the store's responsibility to have a written safety procedures in place. The safety procedure must comply with all applicable codes such as local fire department's codes.

At minimum, the following actions are required:

- Immediately evacuate all persons from the store, and contact the local fire department to advise them that a propane leak has occurred.
- Call Hussmann and/or a qualified service agent and inform them that a propane sensor has detected the presence of propane.
- Do not let any persons back into the store until the qualified service technician has arrived and that technician advises that it is safe to return to the store.
- The propane gas used in the unit has no odor. The lack of smell does not indicate a lack of escaped gas.
- A hand-held propane leak detector ("sniffer") should be used before any repair and/or maintenance is attempted. All repair parts must be identical models to the ones they are replacing.
- No open flames, cigarettes or other possible sources of ignition should be used inside the building where the units are located until the qualified service technician and/or local fire department determines that all propane has been cleared from the area and from the refrigeration systems.



BEFORE YOU BEGIN

Read these instructions completely and carefully.



PERSONAL PROTECTION EQUIPMENT (PPE)

Personal Protection Equipment (PPE) is required whenever installing or servicing this equipment. Always wear safety glasses, gloves, protective boots or shoes, long pants, and a long-sleeve shirt.

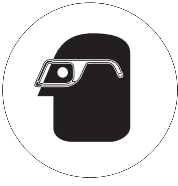

1. If the information in these instructions are not followed exactly, a fire or explosion may result, causing property damage, personal injury or death.
2. Installation and service must be performed by a qualified installer or service agency.
3. This unit is designed only for use with R-290 (propane) gas as the designated refrigerant.

THE REFRIGERANT LOOP IS SEALED. ONLY A QUALIFIED TECHNICIAN SHOULD ATTEMPT TO SERVICE!

- Propane is flammable and heavier than air.
- It collects first in the low areas but can be circulated by the fans.
- If R-290 (propane) is present or even suspected, do not allow untrained personnel to attempt to find the cause.
- The propane gas used in the unit has no odor.
- The lack of smell does not indicate a lack of escaped gas.
- If a leak is detected, immediately evacuate all persons from the store, and contact the local fire department to advise them that a propane leak has occurred.
- Do not let any persons back into the store until the qualified service technician has arrived and that technician advises that it is safe to return to the store.
- A hand-held propane leak detector (“sniffer”) shall be used before any repair and/or maintenance.
- No open flames, cigarettes or other possible sources of ignition should be used inside the building where the units are located until the qualified service technician and/or local fire department determines that all propane has been cleared from the area and from the refrigeration systems.
- Component parts are designed for propane and non-incendive and non-sparking. Component parts shall only be replaced with identical repair parts.

FAILURE TO ABIDE BY THIS WARNING COULD RESULT IN AN EXPLOSION, DEATH, INJURY AND PROPERTY DAMAGE.

ATTENTION

Merchandiser must operate for 24 hours before loading product!

Regularly check merchandiser temperatures.

Do not break the cold chain. Keep products in freezer before loading into merchandiser.

Medium temperature merchandisers are designed for loading ONLY pre-chilled products.

Low temperature merchandisers are designed for loading ONLY frozen products.



IMPORTANT
KEEP IN STORE FOR FUTURE REFERENCE
Quality that sets industry standards!

12999 St. Charles Rock Road • Bridgeton, MO 63044-2483

U.S. & Canada 1-800-922-1919 • Mexico 1-800-890-2900

www.hussmann.com

© 2019 Hussmann Corporation

**INSTALLATION
TOOL LIST**

Unloading From Trailer:

Lever Bar (also known as a Mule,
Johnson Bar, J-bar, Lever Dolly, and
pry lever)
Moving Dolly

Setting Case Line-Up:

Level, 4 ft suggested
Ratchet
1/4 in. Socket
5/16 in. Socket
1/2 in. Socket
Battery Drill/Screw Gun
Caulking Gun
10 in. Adjustable Crescent Wrench

REVISION HISTORY

REVISION D — DECEMBER 2019

1. Revised Section 2 pictures and wording;
changed cover image

REVISION C — APRIL 2019

1. Added new medium temp. models

REVISION B — FEBRUARY 2019



1. Added new low temp. models; updated
Section 2

REVISION A — MARCH 2018

1. Original Issue

A 4-inch (102 mm) space between the rear of the merchandiser and wall must be maintained for air circulation. However, in high ambient conditions, sweating may still occur. If this happens install a method of forced ventilation such as a fan ventilation kit.

ANSI Z535.5 DEFINITIONS

-  • **DANGER** – Indicate[s] a hazardous situation which, if not avoided, will result in death or serious injury.
-  • **WARNING** – Indicate[s] a hazardous situation which, if not avoided, could result in death or serious injury.
-  • **CAUTION** – Indicate[s] a hazardous situation which, if not avoided, could result in minor or moderate injury.
- **NOTICE** – Not related to personal injury – Indicates[s] situations, which if not avoided, could result in damage to equipment.

 **CAUTION**

Do NOT remove shipping crate until the merchandiser is positioned for installation.

 **CAUTION**

Excessive ambient conditions may cause condensation and therefore sweating of doors. Facility operators should monitor doors and floor conditions to ensure safety of persons.

Table of Contents

ANSI Z535.5 DEFINITIONS	v	DRIP PIPING AND SPLASHGUARDS	
INSTALLATION TOOL LIST	v	Waste Outlet and Water Seal	3-1
		Installing Drip Piping	3-1
		Drip Piping Lineup Arrangements	3-4
		Installing Splashguards	3-5
		Sealing Splashguard to Floor	3-6
INSTALLATION		START UP / OPERATION	
UL Listing	1-1	Prior to Start-up Check List	4-1
Federal / State Regulations	1-1	12 Hours After Startup Checklist	4-2
Location	1-1	Startup and Operation	4-3
Shipping Damage	1-1	Stocking	4-3
Exterior Loading	1-2	Load Limits	4-3
Merchandisers Shipped With End Installed	1-2	Installing FDA/NSF Required Thermometer	4-5
Shipping Braces	1-2		
Door Adjustment	1-4	MAINTENANCE	
Installing Splashguard Brackets	1-4	Care and Cleaning	5-1
Joining	1-4	Cleaning Honeycomb Assemblies	5-2
Joining Instructions	1-5	Cleaning Stainless Steel Surfaces	5-3
Installing Bumpers	1-17	Cleaning Coils	5-3
		Cleaning Under Merchandisers	5-3
		Removing Scratches from Bumper	5-3
		SERVICE	
ELECTRICAL / CONTROLLER /		Replacing Fan Motors and Blades	6-1
WATER / REFRIGERATION		Replacing Electric Defrost Heaters	6-2
Electrical	2-1	Replacing Drain Pan Heater	6-3
Merchandiser Electrical Data	2-1	Servicing Vertical Lighting	6-4
Field Wiring	2-1	Servicing Doors and Frames	6-4
Main Disconnect Switch	2-1	Replacing Door or Door Frame Parts	6-4
Plug	2-2	Replacing Damaged Drain Fitting	6-4
Case Electronic Controller	2-3	Repairing Aluminum Coils	6-5
Connecting Device	2-10		
Controller Troubleshooting	2-12	WARRANTY	
Water - (For Condensers)	2-13		
Pre-Installation System Cleaning	2-15		
Refrigeration	2-16		
Condensing Unit Access	2-16		
Defrost	2-17		

INSTALLATION

UL LISTING

These merchandisers are manufactured to meet ANSI/UL 471 standard requirements for safety. Proper installation is required to maintain the listing.

FEDERAL / STATE REGULATION

These merchandisers at the time they are manufactured, meet all federal and state/ provincial regulations. Proper installation is required to ensure these standards are maintained. Near the serial plate, each merchandiser carries a label identifying the environment for which the merchandiser was designed for use. In compliance with DOE 2017, standard low temp Reach In cases with Innovator I Doors are equipped with an anti-sweat controller that maintains the door heat at a level that meets DOE energy limits. Any factory or field-installed anti-sweat controller applied to a low temp Reach In case with Innovator I Doors must be programmed to cycle the heaters at no more than 50% run time at design conditions of 75 degrees, 55% RH for frozen food operating condition.

ANSI/NSF-7 Type I – Display Refrigerator / Freezer
Intended for 75°F (24°C) / 55%RH Ambient Application

ANSI/NSF-7 Type II – Display Refrigerator / Freezer
Intended for 80°F / 55%RH Ambient Application

ANSI/NSF-7 – Display Refrigerator
Intended for Bulk Produce

LOCATION

These merchandisers are designed for displaying products in air conditioned stores where temperature is maintained at or below the ANSI/NSF-7 specified level and relative humidity is maintained at or below 55%.

Placing refrigerated merchandisers in direct sunlight, near hot tables or near other heat sources could impair their efficiency.

Like other merchandisers, these are sensitive to air disturbances. Air currents passing around merchandisers will seriously impair their operation. Do NOT allow air conditioning, electric fans, open doors or windows, etc. to create air currents around the merchandisers. To prevent sweating on the exterior surfaces of merchandisers, there must be a MINIMUM CLEARANCE OF 4 INCHES (102 MM) between the merchandisers and other fixtures or walls. Product should always be maintained at proper temperature. This means that from the time the product is received, through storage, preparation and display, the temperature of the product must be controlled to maximize the life of the product.

SHIPPING DAMAGE

All equipment should be thoroughly examined for shipping damage before and during unloading. This equipment has been carefully inspected at our factory. Any claim for loss or damage must be made to the carrier. The carrier will provide any necessary inspection reports and/or claim forms.

Apparent Loss or Damage

If there is an obvious loss or damage, it must be noted on the freight bill or express receipt and signed by the carrier’s agent; otherwise, carrier may refuse claim. The carrier will supply necessary forms.

Concealed Loss or Damage

When loss or damage is not apparent until after equipment is uncrated, a claim for concealed damage is made. Upon discovering damage, make request in writing to carrier for inspection within 15 days and retain all packing. The carrier will supply inspection report and required claim forms.



EXTERIOR LOADING

Do NOT walk on top of merchandisers or damage to the merchandisers and serious personal injury could occur. THEY ARE NOT STRUCTURALLY DESIGNED TO SUPPORT EXCESSIVE EXTERNAL LOADING such as the weight of a person. Do not store items or flammable materials atop the unit.



This warning does not mean that Hussmann products will cause cancer or reproductive harm, or is in violation of any product-safety standards or requirements. As clarified by the California State government, Proposition 65 can be considered more of a 'right to know' law than a pure product safety law. When used as designed, Hussmann believes that our products are not harmful. We provide the Proposition 65 warning to stay in compliance with California State law. It is your responsibility to provide accurate Proposition 65 warning labels to your customers when necessary. For more information on Proposition 65, please visit the California State government website.

MERCHANDISERS SHIPPED WITH END INSTALLED

If the case was shipped with the end installed, two long bolts were used to hold the shipping brace to the end. If the shipping bolts are reinserted after removing the brace, they will extend into the product area and may damage the coil. THEREFORE, BE SURE TO REPLACE THESE BOLTS WITH THE SHORTER BOLTS PROVIDED.

Be careful not to damage the factory-installed end while moving the merchandiser. Make sure that tools are positioned past the end and beneath the merchandiser's support bar.

SHIPPING BRACES

Move the merchandiser as close as possible to its permanent location and then remove all packaging. Check for damage before discarding packaging. Remove all separately packed accessories such as kits and shelves.



CAUTION

**Do not walk on top of merchandiser.
Do not store items or flammable
materials atop the unit.**

NOTE: BEGIN LINEUP LEVELING FROM THE HIGHEST POINT OF THE STORE FLOOR.

Place shims under the rail and make sure that they are positioned at a base component (crossbar). This transfers the weight directly from the loaded case through to the floor.

Placing shims at other locations will cause uneven distribution of weight leading to piping leaks, as well as sagging or wracked doors.

Bottom front supports must be shimmed if not in full contact with the floor.

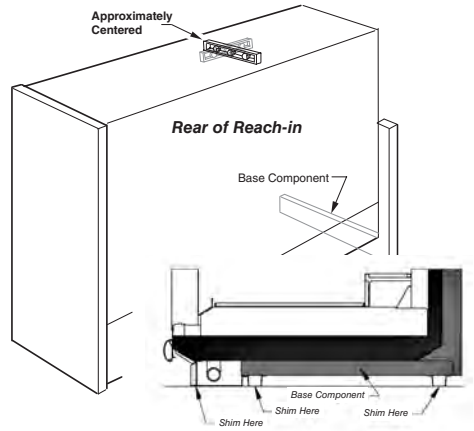



**..ATTENTION
INSTALLER**

It is the installing contractor's responsibility to consult local agencies for local code requirements.

4-Door Shown

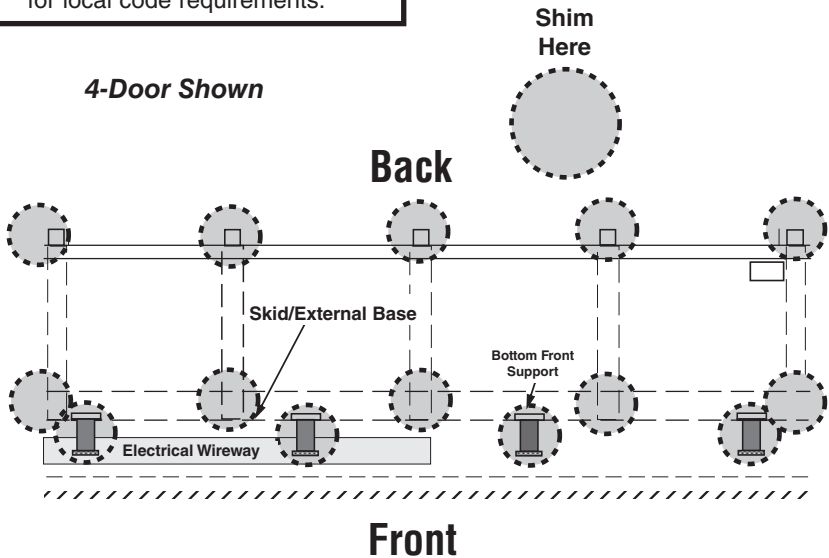

DOOR ADJUSTMENT

After leveling and joining the merchandisers, adjust and level doors according to manufacturer's instructions shipped with each product. Factory settings may be lost due to vibration during shipment.

INSTALLING SPLASHGUARD BRACKETS

1. Attach splashguard retainer and splashguard retainer support to splashguard support bracket using two screws per bracket.
2. Install splashguard support brackets underneath case. The leveling brackets have a maximum extension of one (1) inch (25 mm) for uneven floors.

DO NOT PLACE SHIMS UNDER SPLASHGUARD BRACKETS.

NOTE: Install splashguard support brackets before piping case.

JOINING

Sectional construction means that two or more merchandisers may be joined in line yielding one long continuous display requiring only one pair of ends. Joining kits and instructions are shipped with each merchandiser.

To join like fixtures, a joining kit is required. To join unlike fixtures, or like fixtures operating at different temperatures, a 2 inch (51 mm) partition kit is required. To join same temperature merchandisers on different defrost cycles, a plexiglass partition kit is required.

ALL JOINTS MUST BE AIR-TIGHT TO PREVENT FORMATION OF ICE OR CONDENSATION.

Refer to the instructions on the next page.

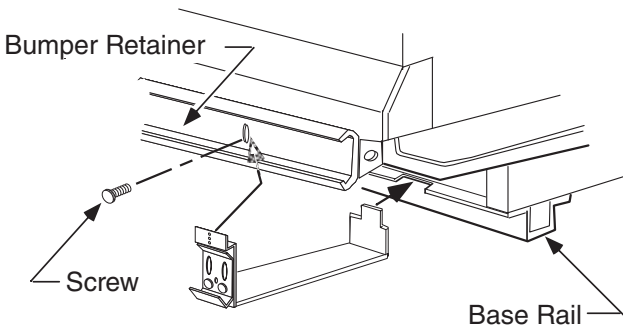
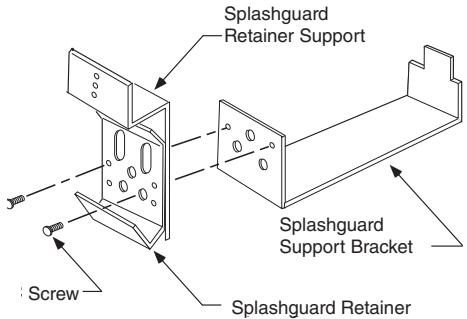

Joining Instructions

Splashguard brackets must be installed before piping or wiring case.

PARTS LIST

<i>Item</i>	<i>Quantity</i>	<i>Description</i>
	RL-W	
1.	2	Donut Gasket
2.	1	Gasket, .906 x 1/2 x 200 in.
3.	1	Gasket, 1/2 x 1/4 x 600 in.
4.	8	Cap Screw 5/16 -18 x 1 1/4
5.	8	Split Lock Washers 5/16
6.	1	Joint Molding
7.	5	Binder Post and Screw
8.	1	Splice Connector

NOTE: Be sure first merchandiser has been leveled according to the main installation instruction. Carefully unpack and inspect the joining parts listed above to verify completeness and that there is no damage.

1 Prepare cases for joining as shown in Figure 1.

- A. Packing materials, bumpers and splashguards should be removed.
- B. Remove shelves (if installed).
- C. Remove display racks and pans from ends to be joined.
- D. Remove plenum covers.

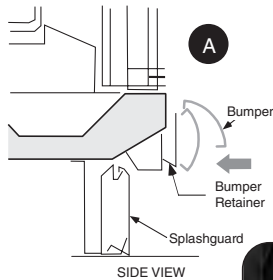
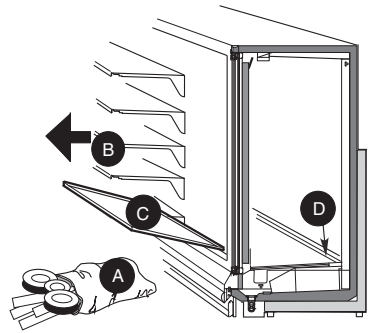
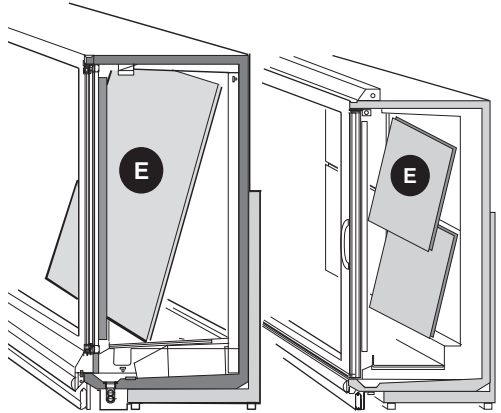

Figure 1. Prepare Cases

RL

E. Remove back panels from ends to be joined by lifting up and out near the bottom. No tools are necessary.



F. Remove joint molding from any door frames that will be joined to another case.



G. RLNI Only: Remove screws and interior top panel on both sides of the island case end to be joined (see Figure 1).



RLNI & RLNI

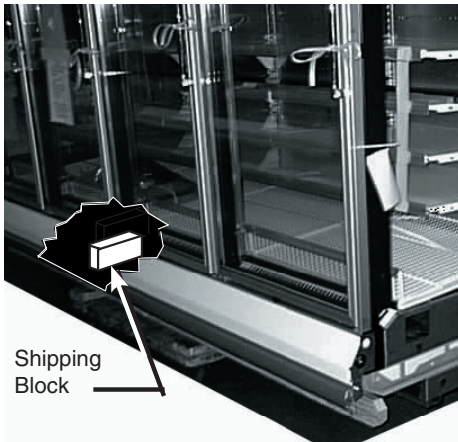

Figure 2. Remove Shipping Block
(One From Each Side of Island Models)

2 Locate and remove the shipping block in the center of the heat exchanger in the interior bottom of each case, see Figure 2.

Snap a chalk line on the floor to use as a guide for positioning the front of the cases in the line-up. The front base frame should be on the chalk line.

3 Once cases are close to final placement, remove the shipping braces from the ends to be joined, see Figure 3. Discard bolts and flat washers used to hold shipping braces. Bolts are too long to be used for joining.



DO NOT USE SHIPPING BOLTS TO JOIN CASES!

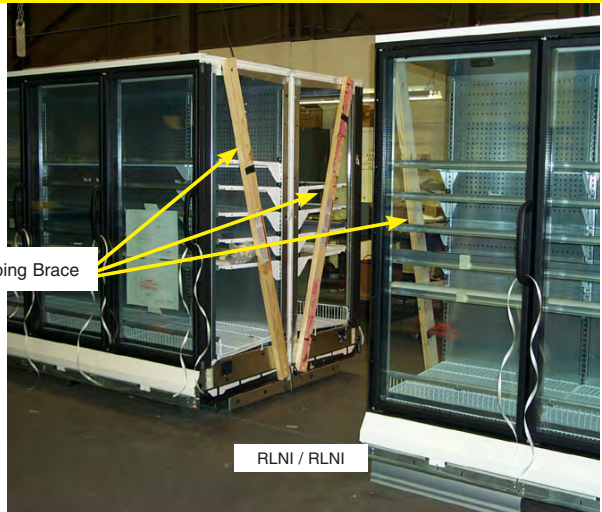
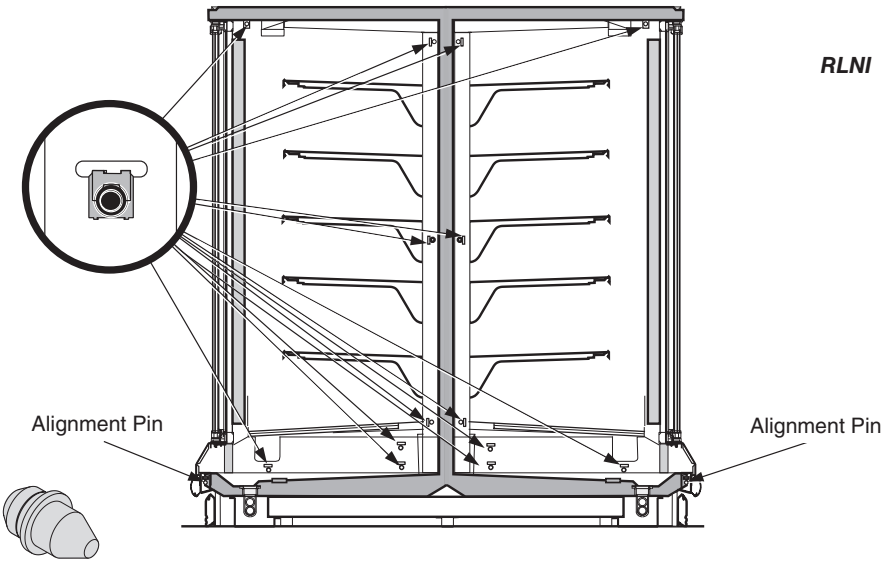
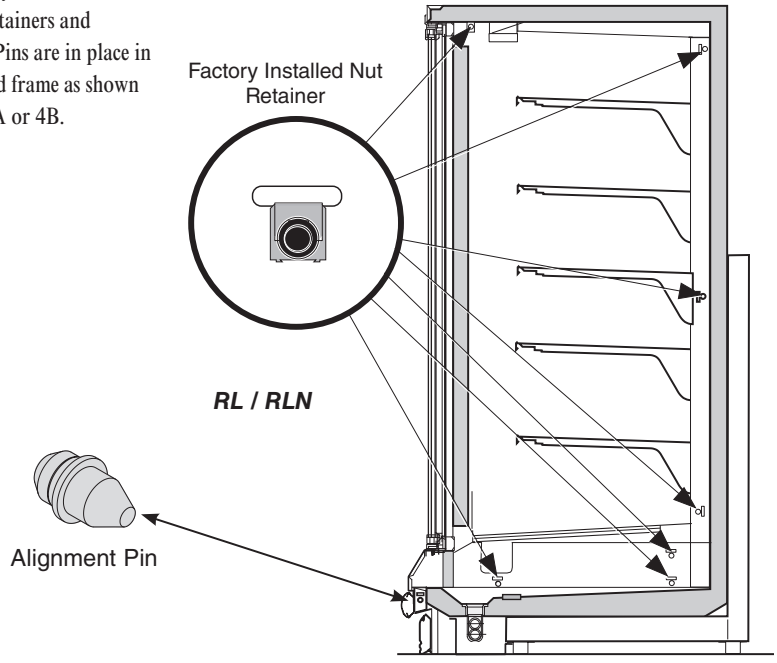

Figure 3. Remove Shipping Braces

4 If not already installed make sure Nut Retainers and Alignment Pins are in place in the right end frame as shown in Figure 4A or 4B.



5 Apply Donut Gasket – 1 in recess around both left end as shown in Figure 5A, Part 1; 5B or 5C, Part 1, and right end frames as shown in Figure 5A, Part 2; 5B or 5C, Part 2.

Apply the wider Foam Tape Gasket — 2 around the right end frame as shown in Figure 5A, Part 2, 5B or 5C, Part 2.

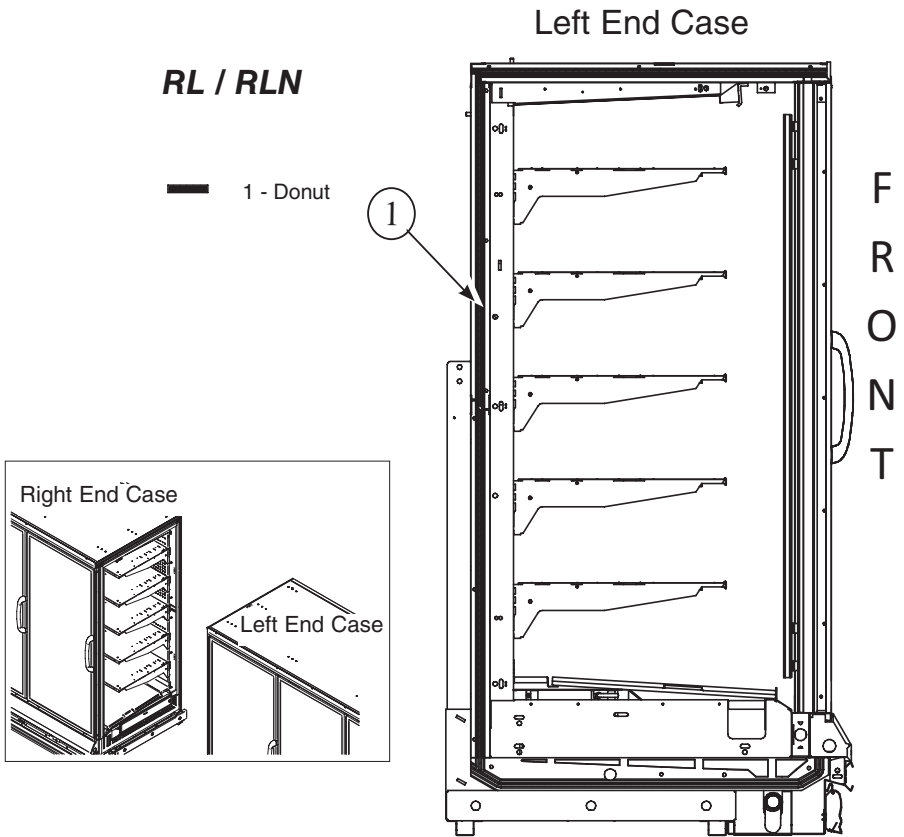

Figure 5A, Part 1. Apply Gasket to Left End

Apply gasket pad to right end first, then apply the narrower Foam Tape Gasket — 3 around the perimeter of the right end frame outside of the donut gasket as shown in Figure 5A, Part 2, 5B or 5C, Part 2.

- Lap gaskets at lower corners.
 - Check that there are no gaps between gasket and case.
 - Do not stretch gasket, especially around corners.
- To make sharp corners, paper backing can be torn without removing from gasket.

- Do not butt gaskets; always lap joints.
- Remove paper backing after gasket is applied to keep gasket free of debris.
- Gasket has high tack adhesive and must be properly placed the first time.

1. Butyl is NOT an acceptable substitute for donut or foam gasket.

RL / RLN

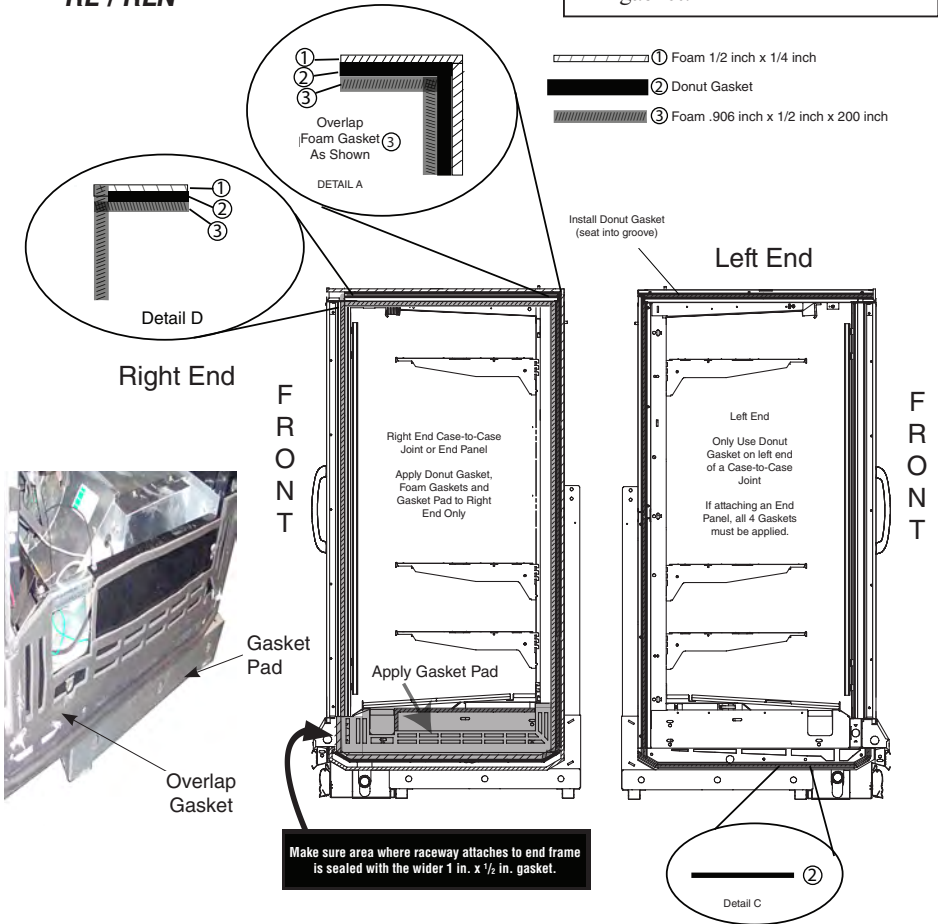

Figure 5A, Part 2. Apply Gaskets to Right End

RLNI
RLNI

Left End Case

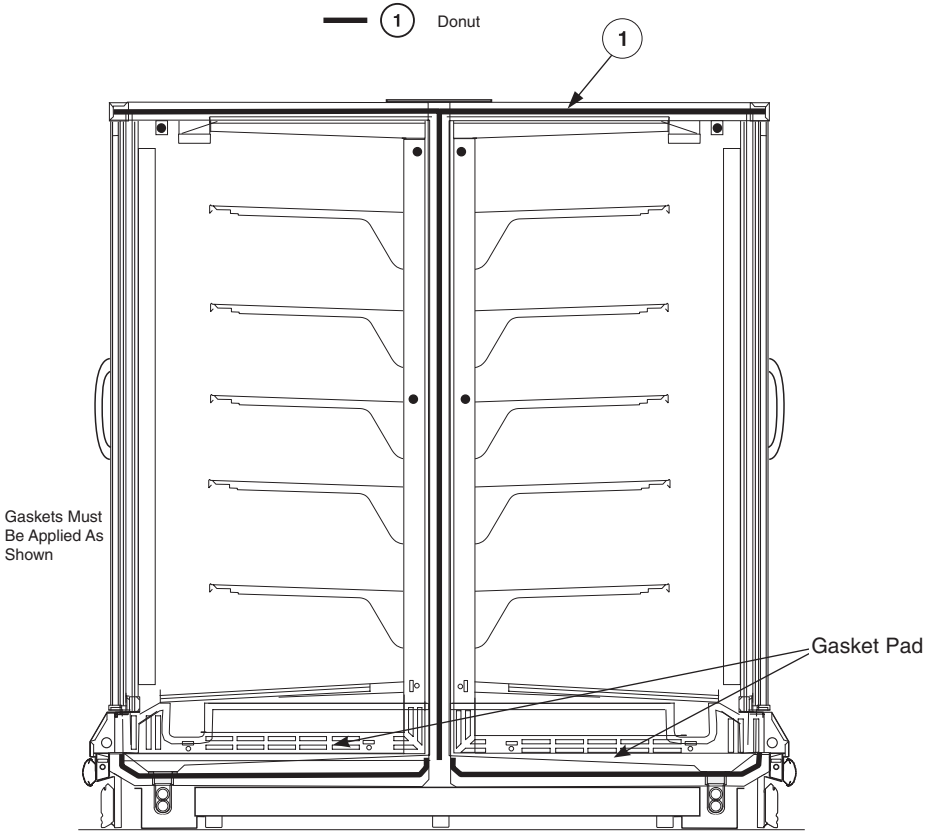

Figure 5A. Apply Gaskets

RLNI
RLNI

Right End Case

- Gaskets
Must Be
Applied As
Shown
- 1 Donut
 - 2 1 in. x 1/2 in.
 - 3 1/2 in. x 1/4 in.

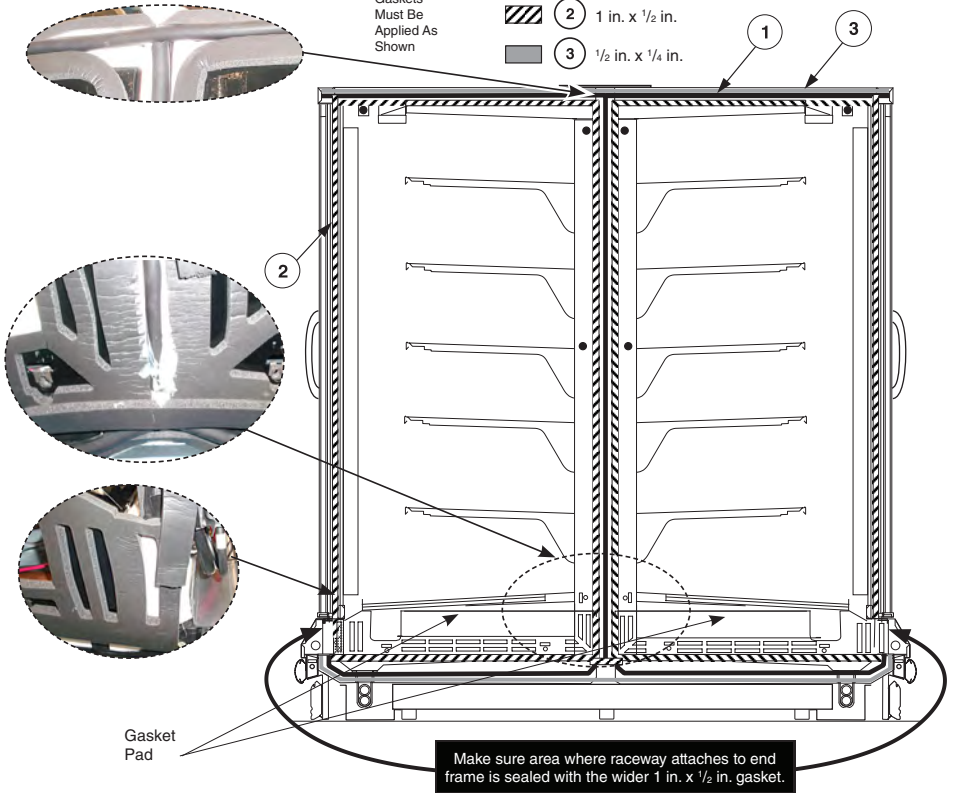

Figure 5B. Apply Gaskets to Right End

6 Move the second merchandiser against first, mating alignment pins with corresponding holes. Use care when pushing the cases together.

RL / RLNI: Do not cut wires routed along the front bumper retainer. See detail in Figure 6.

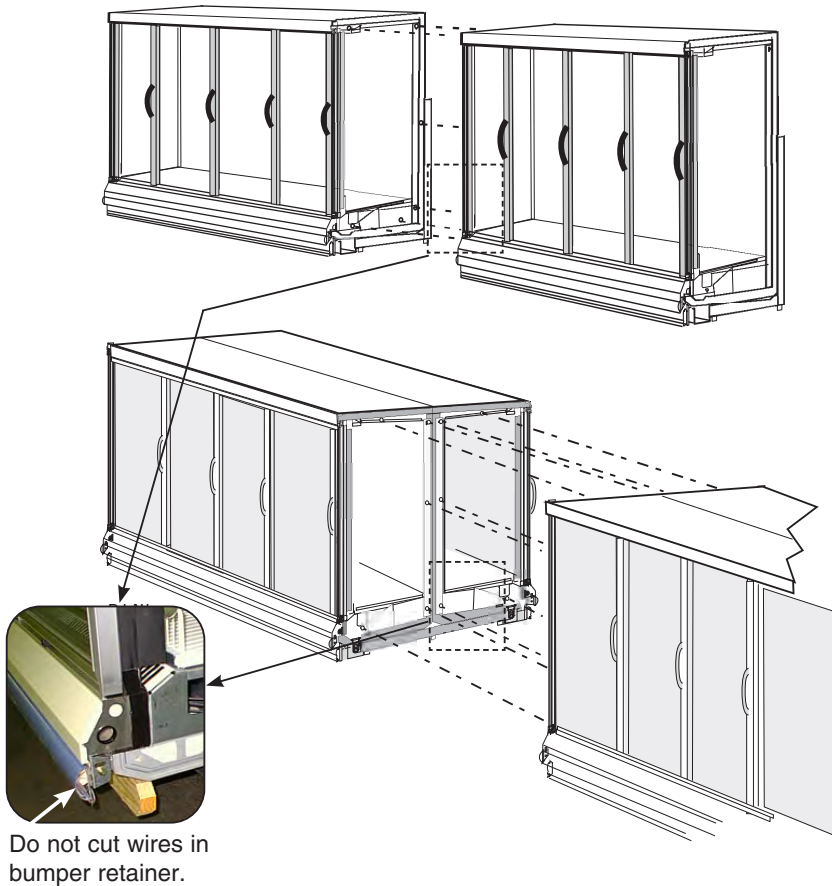

Figure 6. Move Cases Together

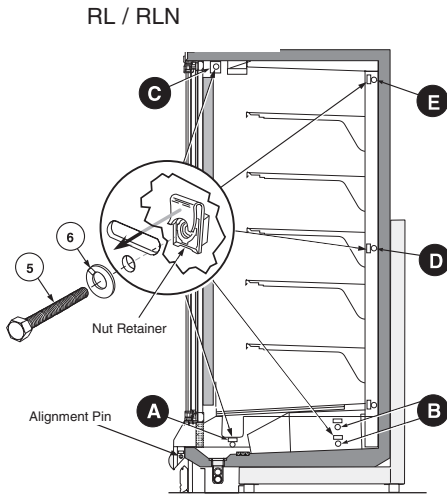

Figure 7A. Joining Sequence

7 Loosely insert Cap Screw – 5 with Lock Washer – 6 into each nut retainer following the sequence shown in Figure 7A. **Do not tighten fully.**

A. Fasten bottom fronts together, but tighten only until front panels touch.

B. Move to the bottom back position and join (2 places).

C. Join at the top front position.

D. Go to the middle back wall position and join.

E. Join at the lower back wall.

F. Finally, join at the top back wall position.

Following the same sequence, tighten each cap screw fully until the merchandisers are joined with a snug fit and gaskets are compressed.

8 Refer to Section 1 of the Reach-In Installation and Service Manual to install splashguard brackets and bumpers. Section 3 provides direction for installing splashguards, including splashguard Splice Connector – 8.

RLNI
RLNI

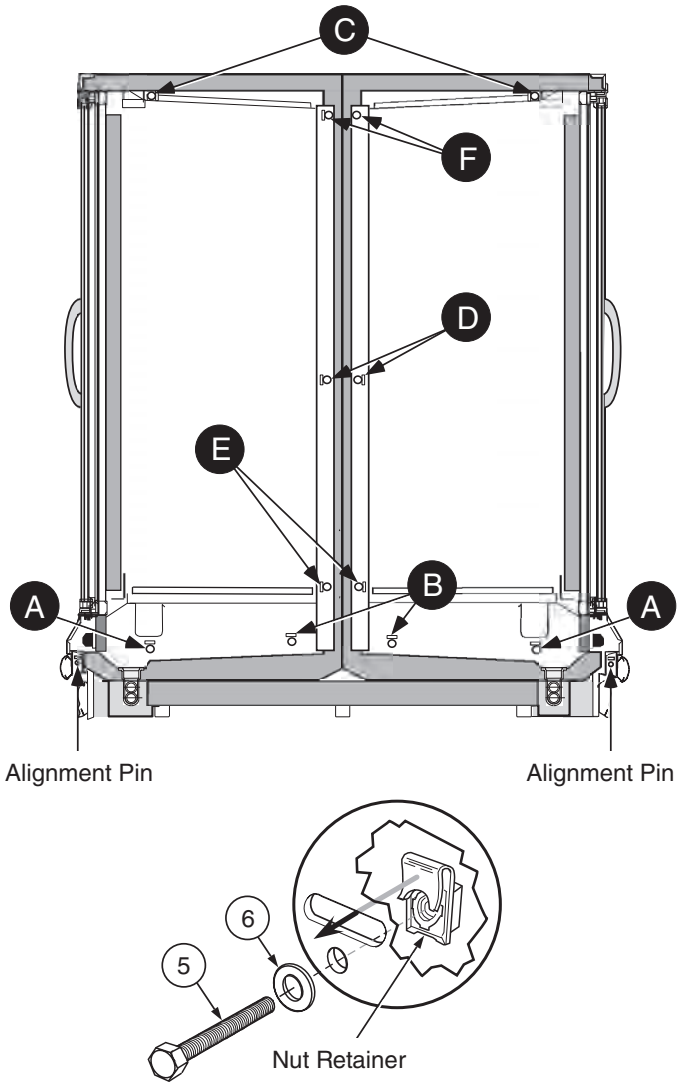
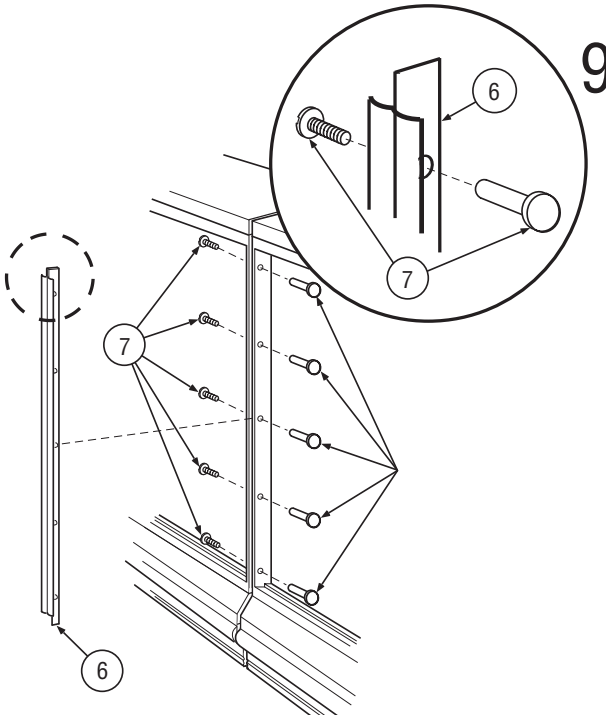

Figure 7C. Joining Sequence for RLNI-W Cases



9

Align holes in frame with holes in Joint Molding – 6. Fasten cases together using Binder Post and Screws – 7 as shown in Figure 8.

Figure 8. Installing “J” Molding

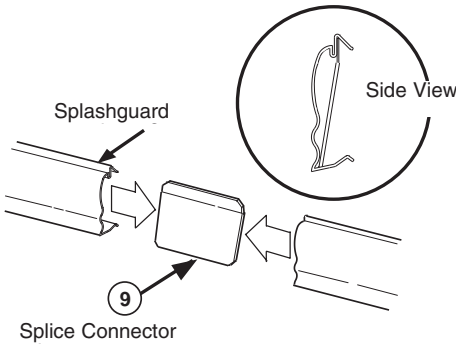

10

Refer to Section 1 of the Reach-In Installation and Service Manual to install splashguard brackets and bumpers. Section 3 provides direction for installing splashguards, including splashguard Splice Connector – 8. shown in Figure 9.

Figure 9. Installing Splashguard Splice Connector

INSTALLING BUMPERS

Offsetting the bumpers and top rails helps to disguise the joint locations, giving the lineup a smoother look.

Begin at the left end of the line-up. A starter bumper is factory-installed with end kits. Insert the internal joint trim, then add the full-length bumper.

Align each bumper section with its retainer and push into place, working from the end of the lineup. Install full length bumpers and internal joint trims offset across joints. Make sure that no gaps exist between sections. Continue installing bumpers the length of the line up.

Do NOT install the last bumper sections at this time. These sections will be installed in the last step.

Once all except the last section of bumper have been installed, refrigerate the case line-up for at least six (6) hours. The last sections of bumper should be kept inside a refrigerated case or cooler during this time to allow the bumpers to contract.

Before installing the last full-length section, measure the remaining space. Use a miter box and fine-tooth saw to cut last bumper to length. Install the last section. Remove protective film from bumpers once installation is complete. Optional end bumpers are factory-installed.

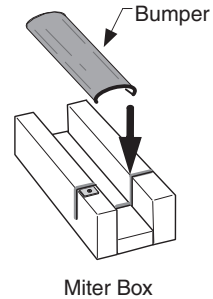
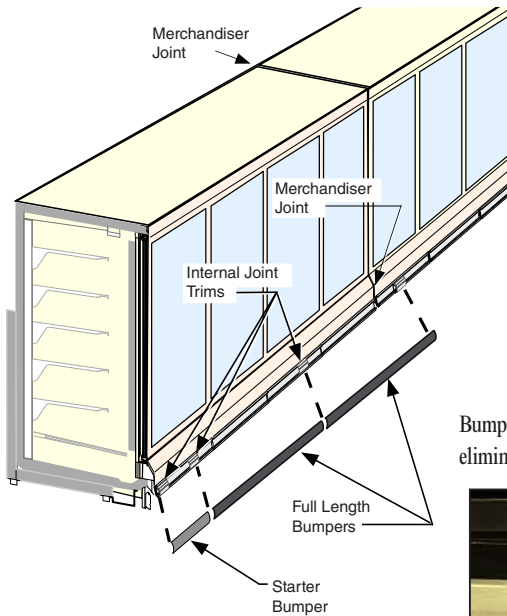

Bumper End Caps can be adjusted horizontally to eliminate gaps.

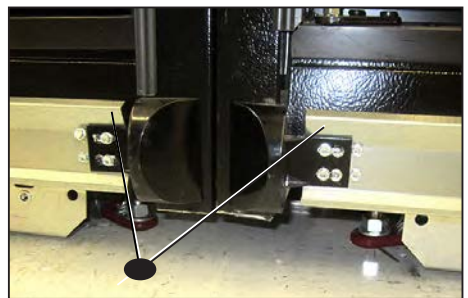

ELECTRICAL / CONTROLLER / WATER / REFRIGERATION

ELECTRICAL

These self-contained merchandisers have watercooled condensers. The evaporator coil is divided into two separate circuits that each have a dedicated refrigeration system. For Reach-In cases, the condensing unit is located on top of the case.

These merchandisers are controlled by the CoreLink Controller.

Cases may be installed as standalone cases with ends, or as part of a lineup. For lineups; Hussmann recommends that the cases be connected to a gateway for defrost coordination, or that partitions are installed between individual cases to prevent frost buildup and other problems that may result from different defrost schedules.

MERCHANDISER ELECTRICAL DATA

Refer to merchandiser serial plate or case data sheets for electrical information.

FIELD WIRING

Field wiring must be sized for component amperes stamped on the serial plate. Actual ampere draw may be less than specified.

ALWAYS CHECK THE SERIAL PLATE FOR COMPONENT AMPERES.

MAIN DISCONNECT SWITCH

Cases are equipped with a main disconnect switch. The switch will interrupt power to the entire case. The switch is located in the electrical box on top of the case, right side when facing the front of the case. The switch is positioned towards the rear of the case. The following image shows the disconnect switch.

THE DISCONNECT SWITCH MUST BE TURNED OFF BEFORE SERVICING THE MERCHANDISER(S).

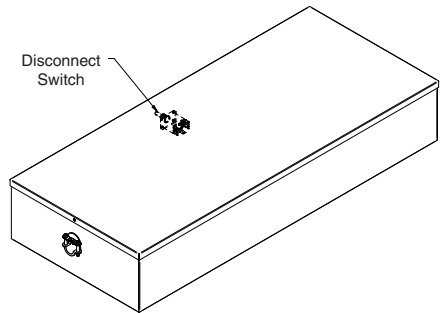

DANGER

Due to risk of ignition resulting from incorrect parts or improper service, only Hussmann authorized personnel may service this equipment. Component parts shall be replaced only with exact manufacturer and model number components. **FAILURE TO USE AUTHORIZED TECHNICIANS COULD RESULT IN AN EXPLOSION, DEATH, INJURY AND PROPERTY DAMAGE.**

These self-contained merchandisers have water-cooled condensers. Each coil section has a dedicated refrigeration system.

All the electrical connections are to be made in the electrical box, located on top of the case at the right side.

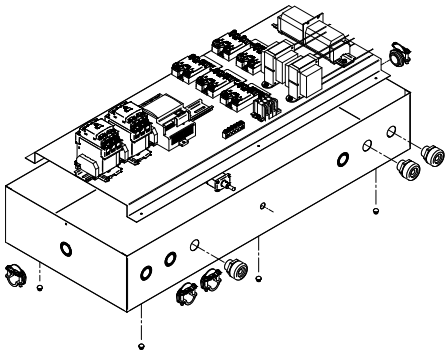

⚠ WARNING
Merchandiser Must be grounded!
All wiring must be in compliance with NEC and local codes.

⚠ ATTENTION INSTALLER

It is the installing contractor's responsibility to consult local agencies for local code requirements.

⚠ WARNING
— LOCK OUT / TAG OUT —
To avoid serious injury or death from electrical shock, always disconnect the electrical power at the main disconnect when servicing or replacing any electrical component. This includes, but is not limited to, such items as doors, lights, fans, heaters, and thermostats.

PLUG

The optional plug cord is 8ft long and is located on the right hand rear of the merchandiser. Disconnect power before servicing. Merchandisers require a dedicated electrical circuit with ground. 12AWG is the minimum sized acceptable wire for a 20-amp circuit.

- 2, 3 and 4-door cases require a dedicated 20-amp / 208V - 3 phase circuit with a grounded wall receptacle (NEMA L21-20R).



- 5-door cases require a dedicated 30-amp / 208V - 3 phase circuit with a grounded wall receptacle (NEMA L21-30R).



- RM-W & RMN-W cases require a dedicated a NEMA 5-15R grounded wall receptacle.



- Always use a dedicated circuit with the amperage stated on the unit.
- Plug into an outlet designed for the plug.
- Do not overload the circuit.
- Do not use long or thin extension cords. Never use adapters.
- If in doubt, call an electrician.

CASE ELECTRONIC CONTROLLER

WARNING
IMPORTANT!

Disconnect electrical power before beginning any service on electrical or electronic equipment. **DO NOT** work around live electrical circuits. Make sure the machine is switched off before working on electrical connections. All operations must be carried out by qualified personnel.

Check that the supply voltage is correct before connecting devices. Never use power that differs from that indicated in the manual. Power supplies other than those specified can seriously damage the refrigeration system or other components and parts.

Separate the cables of the analogue inputs from those of the digital input and the serial line cables from the power cables (resistive as well as inductive), in order to prevent malfunction due to electromagnetic interference.

All system components should be obtained from Hussmann to ensure system compatibility and reliability.

Make connections as short as possible, and do not wind them around electrically connected parts. When connecting loads, follow connection diagrams carefully.

Never connect the secondary of the supply transformer to the earth.

The low voltage connections must have reinforced insulation.

When using the digital inputs of the CoreLink Case Controller use another transformer in order to prevent the digital inputs from malfunctioning or being damaged.

To avoid causing static discharge, do not touch the electronic components on the boards.

DO NOT use the same secondary of the controllers power. Doing so can result in damage to case controller.

DO NOT exceed the maximum current capacity of the onboard controller relays. Always verify the capacity of the output used.

DO NOT plug in accessory devices that are not approved by Hussmann.

DO NOT exceed the maximum current capacity of the onboard controller relays.

Always verify the capacity of the output used.

DO NOT plug in accessory devices that are not approved by Hussmann.

GND is Common(-), not earth ground. Do not earth ground this device.

Permitted Use

- › Food Display Merchandisers
- › Coolers
- › Self-Contained
- › Remote Cases

Improper Use

- › HVAC
- › Unspecified Installation
- › Deviation from established Legislation and Standards

Hussmann is not responsible for misuse or device. Hussmann is not held responsible for deviation from this manual and its intended use. If you have any questions, contact your Hussmann representative for details.

In case of failure or faulty operation, send the controller back to the distributor with a detailed description of the fault.

The controller should not be used for purposes different from those described in this manual. It cannot be used as a safety device.

CASE ELECTRONIC CONTROLLER

Reach-In self-contained R-290 cases are controlled by a CoreLink Electronic Controller, for refrigeration and defrost control and control of lights and fans. The controller is factory programmed with the required parameters to safely operate the merchandiser and maintain required product temperature. There is no need to make adjustments to the controller, however, it is recommended that the program be checked at startup. Refer to the display case data sheet for discharge air temperature, setpoint, defrost cycle and other information.



Control Operation

The case temperature is controlled by cycling the compressor ON and OFF based on the discharge air temperature. On 4- and 5-door cases, the separate refrigeration systems are both controlled by one CoreLink controller that cycles both compressors based on the temperature sensor located above the discharge air honeycomb at the center of the case. The second compressor has a 5 second delay at each startup to prevent excessive startup current.

The discharge air temperature is factory set for -3°F for low temperature cases, and 37°F for medium temperature cases.

There are two methods for accessing CoreLink: The wireless connection kit directly at the CoreLink hosted by Web UI on a connected smart device, or users can use Building Automated System (BAS) to change parameters from a single, central location. For explanation of wireless connection at the case, consult the CoreLink user manual under Web User Interface Section.

NOTE: Individual cases may be designed to run at a specific temperature setting and may not perform well at lower or higher settings, depending on such things as condenser water temperature, ambient conditions, etc.

Defrost is time-initiated, and is programmed with the correct number of defrosts per day and the correct termination. Low temperature cases are temperature terminated at 48°F based on a sensor mounted on the left end of the evaporator coil. The start time for defrost must be programmed using BAS.

Additional Safeties

CoreLink incorporates additional safeties to protect the case from critical failures in an MDS installation. These safeties may, or may not be installed, depending on case model. Following safeties protects the compressors in the event of water system failure or any other blockages in the heat exchanger. Some or all of the safeties are enabled depending on the case model.

Compressor Discharge Temperature Safety

The controller will alarm and disable the compressor output until the temperature falls below threshold.

Compressor Pressure Safety Switch

The controller will disable compressor output when the pressure safety switch is activated. Compressor will resume operation when the safety switch is deactivated.

Compressor Run-time Safeties

Additional run-time safeties are incorporated to protect the compressor and MDS products.

HACCP(Hazard Analysis and Critical Control Points) Temperature Sensor

Controller has input for HACCP temperature reading to be reported out to system managers.
No control logic is active on this sensor.

Available Expansion Modules
HSVD20 - Dual Valve Driver

Used for additional IO for Micro-Distributed Setups.

Application

The application will have the option to support up to three separate zones. To maintain case temperature, the application will use discharge air temperatures and safeties to manage cold operations.

Internal Web Server

The CoreLink case controller features a friendly user interface that can be accessed by web browser.

This Web UI can be accessed by in store network via windows computer or with a wireless link device that can be viewed by technician through smart devices.

Data Logging

The case control application has internal logging for each sensor along with critical operation data. Data is available for local download.

- 2-minute intervals
- 14-day capacity
- Advanced analytics; web user interface
- CSV format with 15 critical data points

Onboard data logging allows user to review performance data from the past week. User can see Min/Max/Average data along with saving data sets and importing data sets for view.

Factory Restore

The CoreLink application has a configuration file with the complete and optimized default case settings.

Anytime a user wants to default to factory settings they can simply access the user interface and force a factory reset.

Save / Load Feature

The CoreLink Case Controller is setup from the factory with a specific product configuration when a customer purchases a display case.

This specific configuration is hardcoded into the controller and is the factory default file. Also included are three user presets that a user can save or load custom configuration settings. These settings allow customers to make small tweaks in the field that can improve performance or target temperatures.

Standalone Operation

Controller is configured from the factory to run as a standalone controller. Field network integrations are done to provide additional capabilities to the controller. In case of network failure of BAS managing additional control functions, controller will default to its standalone settings and regulate display case until network connection is restored.

In case of network failure to building automation system managing case setpoints, the controller will default to program settings in internal memory and continue to regulate display case until network connection is restored.

To learn more about CoreLink Case Controllers including instruction manuals and guides, please visit [Hussmann.com](https://www.hussmann.com).

<https://www.hussmann.com/products/case-controls/case-controls/corelink-case-controller>

WATER - (For Condensers)

Water-cooled condensers are designed to operate with a water/propylene glycol solution, supplied at a temperature of 41°F to 118°F (7.2°C to 47.8°C). A minimum of 10 percent propylene glycol by weight is recommended. If water piping is run outdoors, 35 percent propylene glycol by weight will give burst protection. (not freeze protection), to approximately -40°F (-40°C). Regardless of the amount of propylene glycol, it must be ensured that the water loop has adequate corrosion inhibitors.

Auto balancing valves are optional.

The inlet and outlet water connections are attached using a 3/4 inch NPTF adapter.

Trapped air must be removed at high points of the water piping. Automatic air vent valves or manual valves may be used and should be located at high points in the piping by installing contractor.

The water flow requirements for each case are:

RLW	
2-door:	1.5 GPM
3-door:	2.0 GPM
4-door:	2.5 GPM
5-door:	3.0 GPM

RMW	
2-door:	1.0 GPM
3-door:	1.0 GPM
4-door:	1.0 GPM
5-door:	1.5 GPM

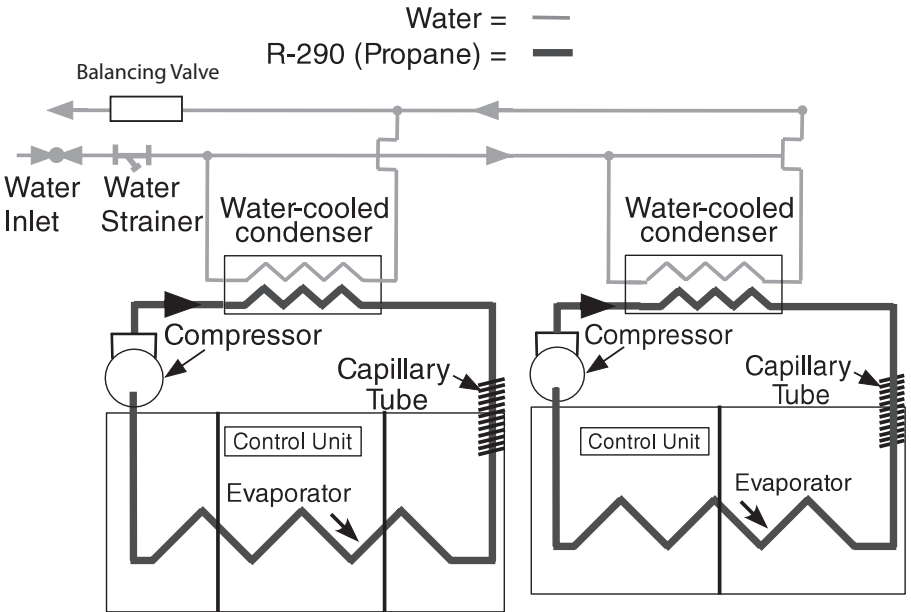

Note: Evaporator coil is one coil with two separate circuits, represented here by showing two separate coils.

Water Flow Diagram

Top Mounted Connections
Water and Electrical

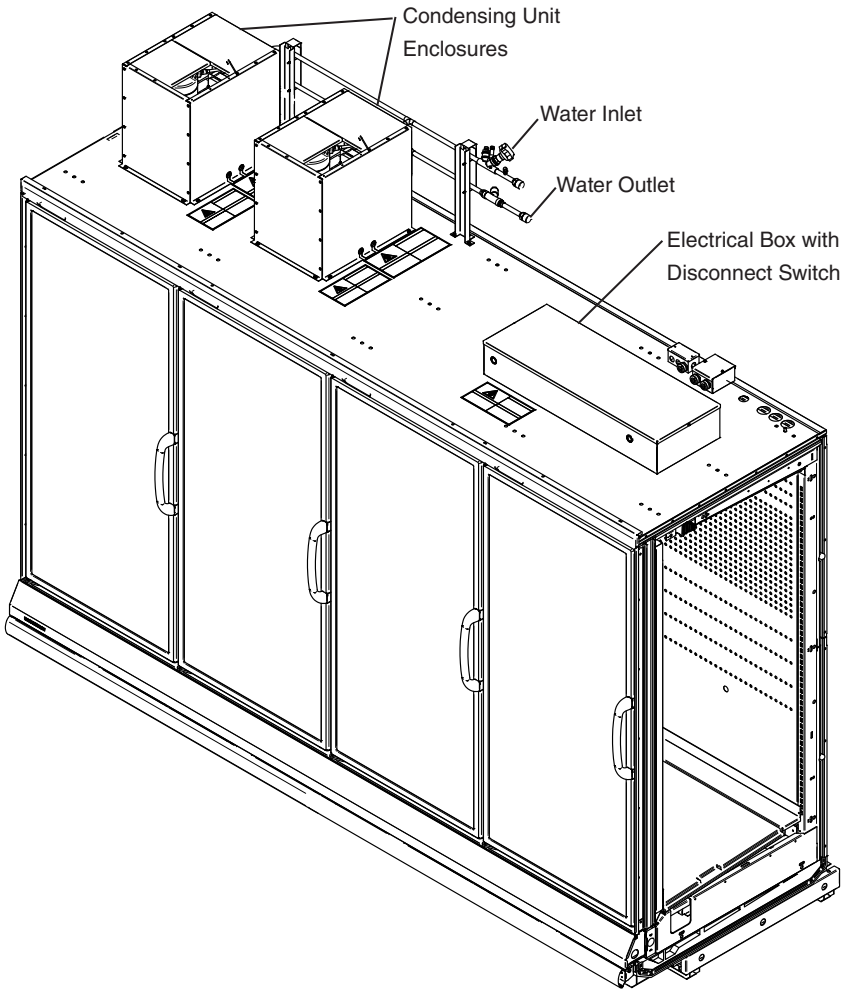

Hussmann recommends using DOWFROST™ inhibited propylene glycol.

Pre-diluted solutions (35% inhibited propylene glycol) of DOWFROST™ are available from Dow. The ingredients in DOWFROST™ have been approved by the FDA and are listed as chemically acceptable by USDA.

The Dow Chemical Company
Midland, MI 48674
1-800-447-4369
www.dow.com

Requirements on system fluid:

Pre-mixed 35% inhibited propylene glycol

Typical Fluid Properties

Solution Composition is 35% inhibited propylene glycol by weight

pH of Solution 8.0 – 10.0

Specific Gravity (at 60°F) 1.033

Viscosity (at 20°F) 14.2 cP

Boiling Point of Solution 217°F

Freezing Point of Solution 2°F

Refractive Index (at 72°F) 1.3733

System Balancing

Balancing may be required to provide adequate coolant flow to each circuit in order to maintain the required waterflow. Balancing is achieved through the setting of balance valves located throughout the system piping.

The installation contractor must consult and be familiar with the manufacturer's Material Safety Data Sheets (MSDS) before handling any secondary fluid. The MSDS contains proper disposal and safety methods.

Automatic Balancing Valves

Case may be equipped with automatic balancing valves. The case will maintain the correct flow rate. The cooling system pressure must be between 5 to 30 psid for proper operation of the automatic balancing valves. Water flow data is provided in the MDS case data sheets, including required flowrate, pressure drop, and heat of rejection.

PRE-INSTALLATION SYSTEM CLEANING

Dow recommends the new piping system be cleaned using a 1-2% solution of trisodium phosphate (TSP), or equivalent cleaner and distilled or deionized water to remove grease, mill scale, or other residues from construction.

Repeat this process if necessary until the drained solution is clear and free from visible debris. The system should then be drained and flushed again using distilled or deionized water.

Hussmann only recommends distilled or deionized water for system flushing with 2% TSP. Dry nitrogen can be used for the initial pressure test, (60 to 75 psi), hold for three hours.

NOTICE

Use only distilled or de-ionized water for flushing with 2 percent TSP. Use a pre-mixed inhibited glycol solution. If the mixing is to be done on site, use only distilled or de-ionized water. Do not use tap water.



! DANGER

Risk of fire or explosion. R-290 (propane) refrigerant is flammable, and the refrigeration system should be serviced or repaired only by trained service personnel. Do NOT puncture refrigerant tubing.

REFRIGERATION

Each self-contained case is equipped with its own condensing unit (2 units on 4- and 5-door cases). The refrigeration system is factory charged and sealed. Each case has one electronic controller.

Self contained merchandisers use R-290 (propane), refrigerant. All models have compressor(s). The systems employ capillary tubes for refrigerant flow control. If the capillary tube becomes plugged or damaged, replace the entire capillary tube. Refer to the case serial plate for refrigerant charge information. The following illustration shows the details of the refrigeration system.

CONDENSING UNIT ACCESS

Condensing units are located on top of the case. The condensing unit(s) have an electrical box for wire connections and field service. All the cases and condensing units' electrical connections are done at the factory.

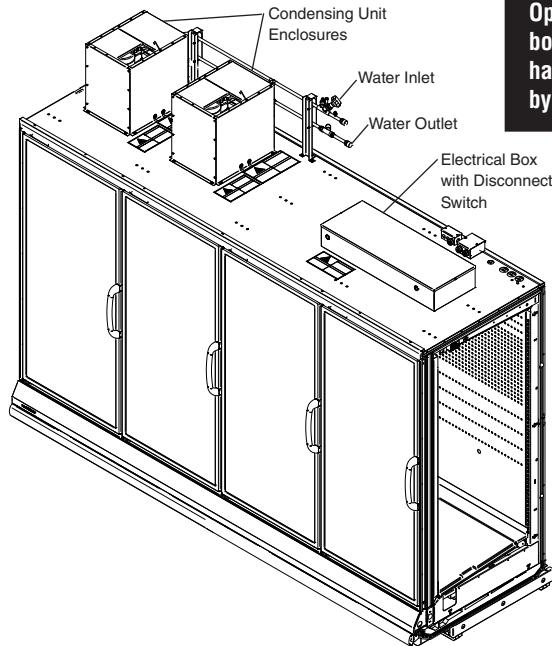

! WARNING

Attention trained service personnel: Mandatory safety service procedures must be followed when servicing refrigeration system.

! WARNING

Opening condensing unit electrical box exposes personnel to electrical hazard and should only be preformed by a qualified service technician.

If a leak is detected, follow store safety procedures. It is the store's responsibility to have a written safety procedure in place. The safety procedure must comply with all applicable codes such as local fire department's codes.

At minimum, the following actions are required:

- Immediately evacuate all persons from the store, and contact the local fire department to advise them that a propane leak has occurred.
- Call Hussmann and/or a qualified service agent and inform them that a propane sensor has detected the presence of propane.
- Do not let any persons back into the store until the qualified service technician has arrived and that technician advises that it is safe to return to the store.
- The propane gas used in the unit has no odor. The lack of smell does not indicate a lack of escaped gas.
- A hand-held propane leak detector ("sniffer") should be used before any repair and/or maintenance is attempted. All repair parts must be identical models to the ones they are replacing.
- No open flames, cigarettes or other possible sources of ignition should be used inside the building where the units are located until the qualified service technician and/or local fire department determines that all propane has been cleared from the area and from the refrigeration systems.

Compressor Safety

The CoreLink Controller for these cases is programmed with a compressor discharge safety that cuts power to the compressor if the discharge temperature exceeds 260°F to protect the compressor in the event of high cooling water temperature or other malfunctions. It uses a sensor that is located on the compressor discharge line of each compressor, and each compressor is controlled independently. This also provides an alarm if the temperature is exceeded.

Sequence of Operation:

Refrigeration:

Compressor is cycling on discharge air temp. Fans stay on when compressor cycles off.

Ice Cream application: Setpoint -10°F average discharge air temp, 6°F differential

Medium Temp application: Setpoint 37°F average discharge air temp, 6°F differential

Frozen food application: Setpoint -3°F average discharge air temp, 6°F differential

DEFROST

Once per day

Low temperature:

Fans off during defrost
Defrost heaters on
Drain pan heater on
Compressor off

Medium temperature:

Fans on during defrost
No defrost or drain pan heaters
Compressor off

Defrost Termination

Defrost is terminated by a sensor located on the following locations:

2 and 3 door cases: Left return bend, center of the coil
4 and 5 door cases: Right return bend, center of the coil

When defrost terminates, the fans stay off until defrost termination sensor reaches 20°F to provide a drip cycle (for low temperature cases).

Defrost is initiated and terminated for both units at the same time, and terminates when the defrost termination sensor reaches 48 degrees. The controller incorporates a 5-second delay between startup of the two compressors.

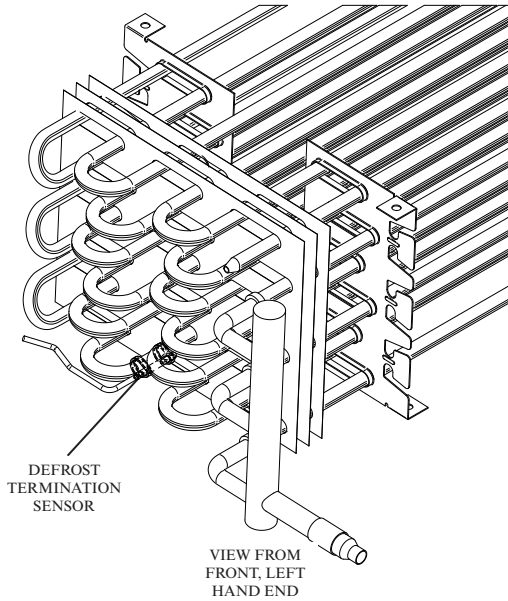

Water connection size: A $\frac{3}{4}$ " female hose fitting is required to connect to the $\frac{3}{4}$ " male hose fitting that is provided on top of the case for inlet and outlet water connections. Optional hose kits are available that include two 6' hoses with $\frac{3}{4}$ " female NPSM fittings. Maximum working pressure of water side components: 100 psig

FRONT OF THE CASE →

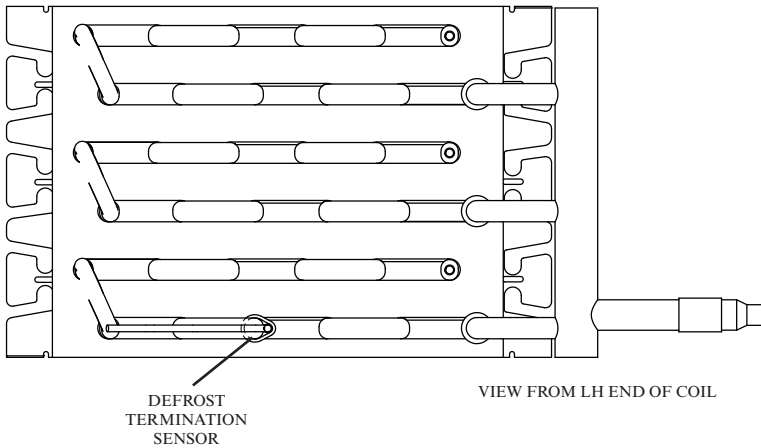

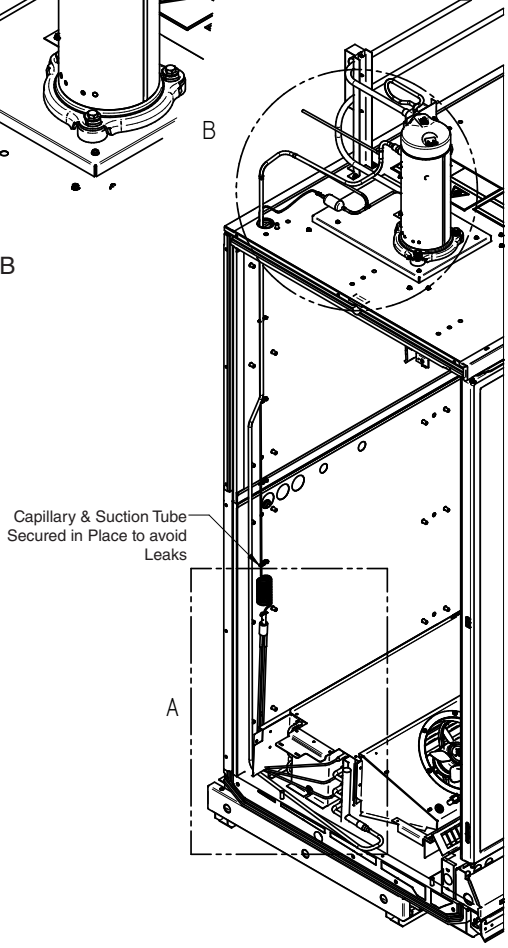
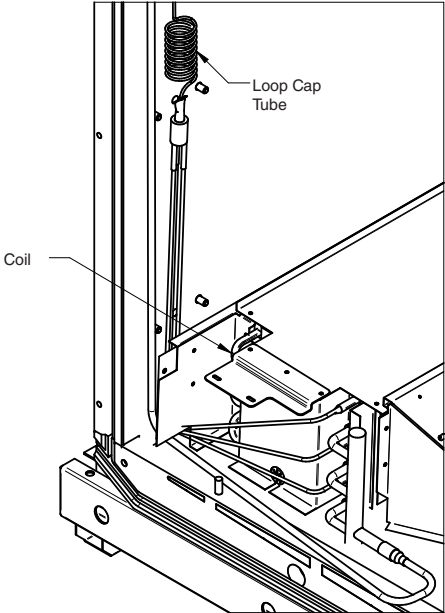
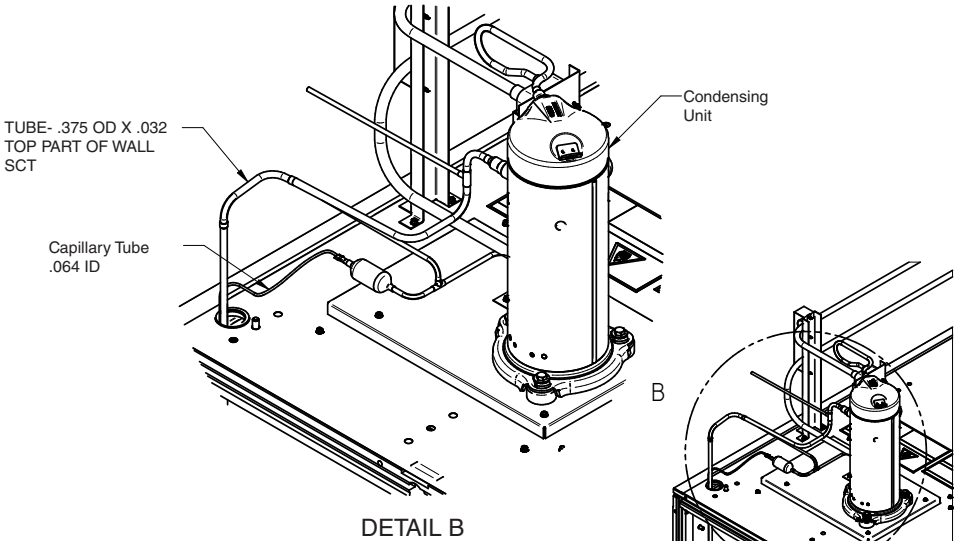

DRIP PIPING AND SPLASHGUARDS

WASTE OUTLET AND WATER SEAL

The waste outlet location varies for each of the 1, 2, 3, 4, and 5-door merchandisers. Drip piping is located between the front merchandiser base and the splashguard fixture and runs parallel to the merchandiser (see Data Sheet for exact locations).

INSTALLING DRIP PIPING

Poorly or improperly installed drip pipes can seriously interfere with the merchandiser's operation and result in costly maintenance and product losses. Please follow the recommendations listed below when installing drip pipes to ensure proper installation.

- Never use drip piping smaller than the nominal diameter of the pipe or water seal supplied with the merchandiser.
- When connecting drip piping, the water seal must be used as part of the drip piping to prevent air leakage or insect entrance. Never use two water seals in series in any one drip pipe. **DOUBLE WATER SEALS IN SERIES WILL CAUSE AN AIR LOCK AND PREVENT DRAINING.**
- Pitch the drip piping in the direction of flow. There should be a minimum pitch of $1/4$ in. per ft (20 mm per 1 m).
- Avoid long runs of drip piping. Long runs make it impossible to provide the pitch necessary for good drainage.

CAUTION

Splashguard brackets MUST be installed before piping merchandiser.
(See Page 1-3)

- Provide a suitable air break between flood rim of the floor drain and outlet of drip pipe. To meet code on low base merchandisers, it may be necessary to install a field-supplied drip pipe reducer. An alternative is to cut the last section of drip pipe at an angle.



- Prevent drip pipes from freezing sweating or freezing:
 - A. Do NOT install drip pipes in contact with uninsulated suction lines. Suction lines should be insulated with a non-absorbent insulation material.
 - B. Where drip pipes are located in dead air spaces, such as between merchandisers or between a merchandiser and a store wall, provide means to prevent drip pipe from sweating. External ventilation fans may be required to prevent sweating.

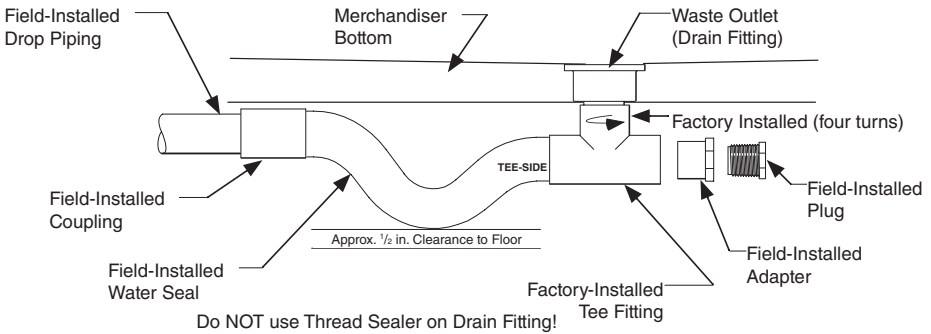

1. Tee is factory-installed. Do not overtighten threads, or the drain fitting or tee may become damaged.
2. Do NOT use thread sealer on ABS drain fitting. If sealer is used the ABS drain fitting may crack or leak! (If a tee needs to be installed it should be tightened no more than 4 turns.) Do not overtighten threads.
3. Dry fit the supplied water seal / trap to ensure approximately 1/2 in. of clearance from the bottom of the trap to the floor as shown.

NOTE: It may be necessary to rotate water seal (trap) inside the tee a few degrees to ensure clearance at two locations. There must be clearance 1) between the bottom of the water seal and the floor, and 2) between the top of the water seal outlet and the bottom of the merchandiser. Do not over-rotate or gravity seal may be compromised. Always rotate trap bottom toward merchandiser support rail.

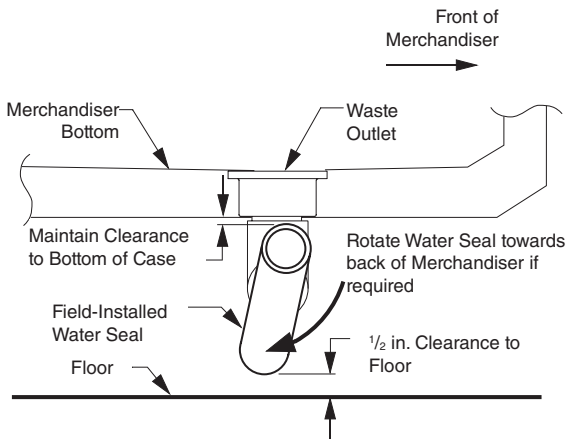

4. Install remaining PVC drain parts using recommended PVC cleaner, primer and cement per manufacturer's recommendations.
5. Thread plug into the adapter until snug but not to exceed four full rotations.
6. Installed drip piping may require additional support depending on the number and location of the hub floor drains. The installer should always provide adequate support to all drip piping arrangements to prevent excess stress on all drip piping components. The installer must provide additional support when "evac" type waste water systems are applied.

It is the installing contractor's responsibility to consult local agencies for local code requirements.

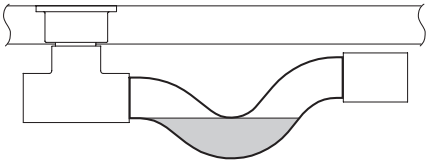

**Water Seal
Correct**

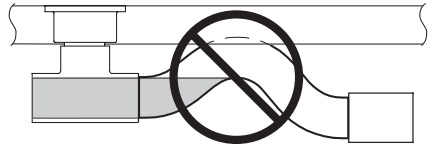

**Water Seal
NOT Correct**

DRIP PIPING LINEUP ARRANGEMENTS

The following illustrations below show typical arrangements for installing drip pipes for a lineup of merchandisers. Illustrations are for reference only. Piping may vary with location and access to hub drain(s). Each merchandiser waste outlet must be individually piped to a hub drain if $\frac{1}{4}$ in. drip piping pitch cannot be maintained.

NOTE: No more than two merchandiser are to be piped per water seal. Do not install water seal between two merchandiser waste outlets that are piped together. **(Double water seals in series will cause an air lock and prevent drainage.)**

RL, RLN Single Line Up (4 merchandisers shown)

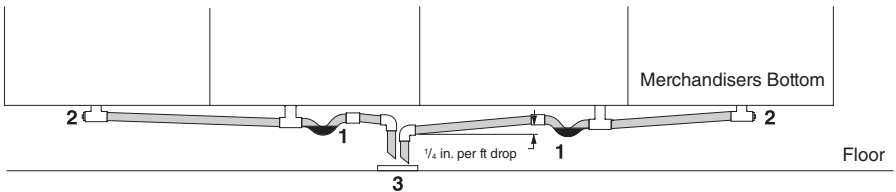

RL, RLN Single Line Up (4 merchandisers shown)

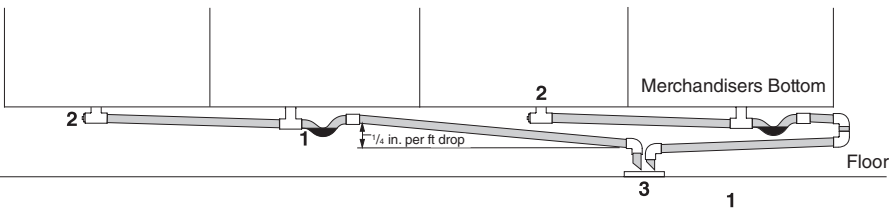

RLNI Cross Drip Piping (4 merchandisers shown)

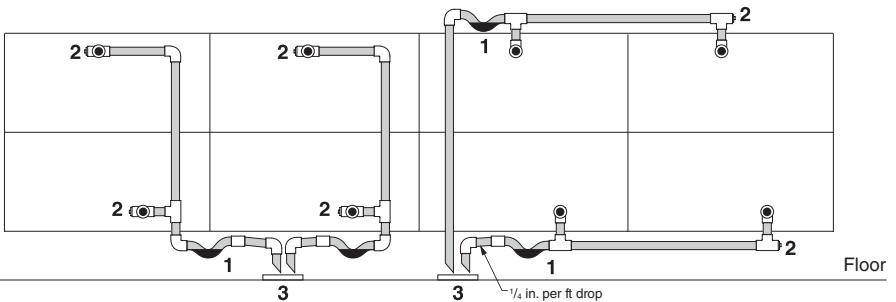

1 = Water Seal 2 = Clean Out Plug 3 = Hub Drain

INSTALLING SPLASHGUARDS

The splashguard is shipped inside each merchandiser. AFTER merchandisers have been leveled and joined, and all drip piping, electrical and refrigeration work has been completed, re-install the front color panel, then install the splashguards.

First, position top of splashguard over the top edge of the bracket; second, push the lower edge of the splashguard toward the bottom of the bracket until it snaps into place.

Splashguards are joined with a galvanized metal splice connector that comes with the joint kit. Join the splashguards before installing on case.

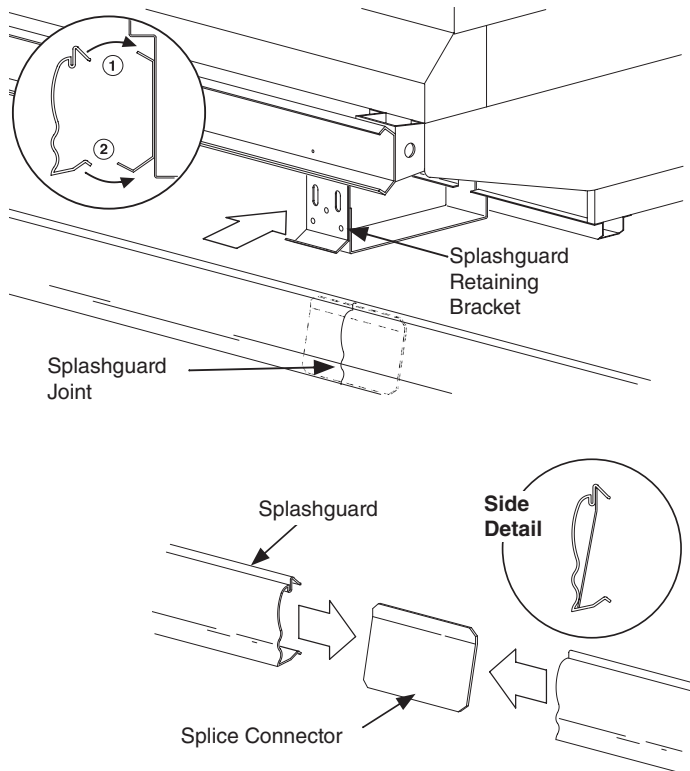

SEALING SPLASHGUARD TO FLOOR

IF REQUIRED by local sanitation codes, or if desired by the customer, plastic splashguards may be sealed to the floor using silicone type sealer. The amount needed will depend on how much the floor is out of level.

- Remove all dirt, wax and grease from the area of the splashguard where adhesion will be necessary. This is to ensure a good, secure installation.
- Apply a good silicone type sealer along the bottom of the splashguard. Sealant must be removed and replaced when servicing.

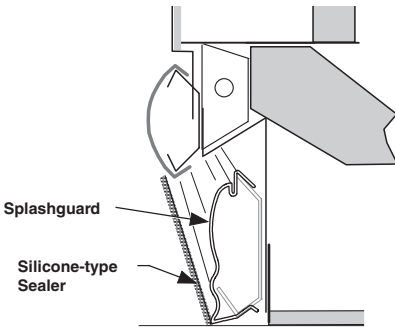

OPTIONAL stainless steel splashguards may be sealed to the floor using a vinyl cove base trim. The size of trim needed will depend on how much the floor is out of level.

To install the trim to the splashguard:

- Remove all dirt, wax and grease from the area of the splashguard where adhesion will be necessary. This is to ensure a good and secure installation.
- Apply a good contact cement to the cove trim and allow proper drying time according to the directions supplied with the cement.
- Install the trim to the splashguard so that it is lying flush with the floor. **DO NOT SEAL THE TRIM TO THE FLOOR.**
- **If required by local health codes** Cove Trim may be sealed to the floor using a silicone type sealer. Sealant must be removed and replaced when servicing.

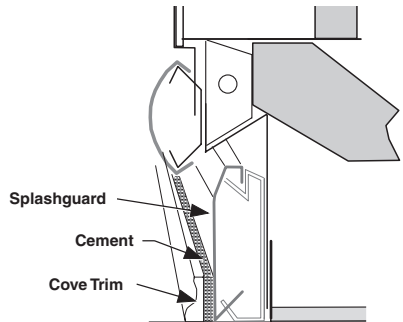

START UP / OPERATION

If a leak is detected, follow store safety procedures. It is the store's responsibility to have a written safety procedures in place. The safety procedure must comply with all applicable codes such as local fire department's codes.

At minimum, the following actions are required:

- Immediately evacuate all persons from the store, and contact the local fire department to advise them that a propane leak has occurred.
- Call Hussmann and/or a qualified service agent and inform them that a propane sensor has detected the presence of propane.
- Do not let any persons back into the store until the qualified service technician has arrived and that technician advises that it is safe to return to the store.
- The propane gas used in the unit has no odor. The lack of smell does not indicate a lack of escaped gas.
- A hand-held propane leak detector ("sniffer") should be used before any repair and/or maintenance is attempted. All repair parts must be identical models to the ones they are replacing.
- No open flames, cigarettes or other possible sources of ignition should be used inside the building where the units are located until the qualified service technician and/or local fire department determines that all propane has been cleared from the area and from the refrigeration systems.

Prior to Start-up Check List

- Is the case connected to its proper nameplate power supply?
- Is there power on at the breaker panel?
- Are the water hand valves open?
- Is the cooling water system on and circulating water through the condenser(s)?
- Are there any leaks from condenser water connections? Clamps may need to be tightened.
- Are the doors properly torqued and self closing? Check each door at the fully open position and at 1-inch open position.
- Do evaporator fans rotate freely? Are they plugged in? (Inspect fans by lifting the deck pans in the bottom of the cases; manually rotate each fan to confirm free rotation and visually inspect that they are plugged into the receptacles.)
- Is the water strainer clear of debris?

Starting up the case

- Ensure the water flow is on, and turn the disconnect switch to the ON position.

The case(s) will start automatically within 4 minutes. The controller will be activated and the case will begin to cool down.



WARNING

Possible hazardous condition. Follow safety procedures outlined by store safety management.

NOTE: Compressor startups are staggered to prevent high electrical circuit demand.

Once the cases are running, listen for any unusual sounds or events.

Examples include:

Evaporator fan blade interference. Compressors should run continuously at startup. Use an amperage meter to check the current to each compressor.

CHECK each fan to ensure it is running. The discharge air output at the top inside front of the case (honeycomb area) should be relatively even across the length of the case. VERIFY there are no leaks at connections for the condenser water.

12 HOURS AFTER STARTUP CHECKLIST

- Check case temperature.
- Check if there is any CoreLink alarm.
- Check water connections for leaks or accumulation of water.
- Verify the fans are running.
- Check compressor's amperage, and validate with the information on serial plate.
- Check the door operation again to ensure doors open and close properly once the case is down to operating temperature.
- Check that all inspection plates and covers have been properly replaced.

- Inspect for any water accumulation due to incorrect or unsealed penetrations where electrical or other lines pass through insulated walls of the case.

- Verify that the lights are "ON". (lights are switched remotely.) If lights are "OFF", check the illumination schedule and circuit breaker for the lights.

- Check the water outlet temperature from each condensing unit. Water outlet temperature should be less than 10° above water inlet temperature.



DANGER

Due to risk of ignition resulting from incorrect parts or improper service, only Hussmann authorized personnel may service this equipment.

Component parts shall be replaced only with exact manufacturer and model number components. FAILURE TO USE AUTHORIZED TECHNICIANS COULD RESULT IN AN EXPLOSION, DEATH, INJURY AND PROPERTY DAMAGE.

STARTUP AND OPERATION

See the merchandiser's Technical Data Sheet for refrigerant settings and defrost requirements. Bring merchandisers down to the operating temperatures listed on the data sheet.

Excessive ambient conditions may cause condensation and therefore sweating of doors. Facility operators should monitor doors and floor conditions to ensure safety of persons.

STOCKING

Product should NOT be placed in merchandisers until all refrigeration controls have been adjusted and merchandisers are at proper operating temperature.

All shelves and the lower deck are intended to display product. Shelf height is adjustable in one inch increments. Spacing of 10 inches is recommended for most applications. Maximum load per shelf is 200 pounds.

Proper rotation of product during stocking is necessary to prevent product loss. Always bring the oldest product to the front and set the newest to the back.

AIR DISCHARGE AND RETURN FLUES MUST REMAIN OPEN AND FREE OF OBSTRUCTION AT ALL TIMES to provide proper refrigeration and air curtain performance. Do not allow product, packages, signs, etc. to block these grilles. Do not use non-approved shelving, baskets, display racks, or any accessory that could hamper air curtain performance.

Do not prop doors open while stocking. And keep the doors closed as much as possible to prevent coil frosting and high merchandiser temperature.

Hussmann recommends solid shelves for ice cream.

LOAD LIMITS

Shelf life of perishables will be short if load limit is violated. AT NO TIME SHOULD MERCHANDISERS BE STOCKED BEYOND THE LOAD LIMITS INDICATED.

Various shelf depths are offered with Reach In cases. The standard depth on all Reach-In cases is 22" (21" on RFLNS and RFMNS cases). Some cases have been designed to support larger shelves, but require design modifications to support the extra shelf length. These cases have a label near the serial plate that reads: This case has been reinforced to support 26" shelves.

DO NOT INSTALL 26" SHELVES IN ANY REACH IN CASE THAT DOES NOT HAVE THIS LABEL.

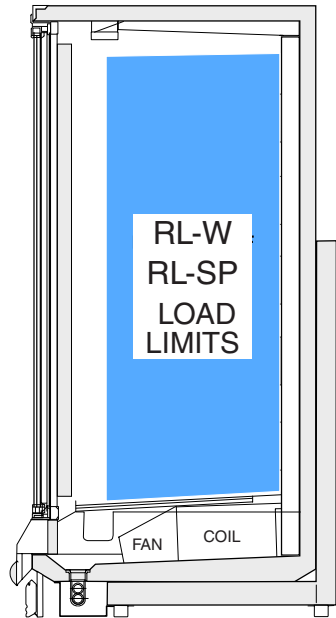

DO NOT BLOCK HONEYCOMB.

⚠ CAUTION

**Do not store items or flammable materials atop the unit.
Do not walk on case.**

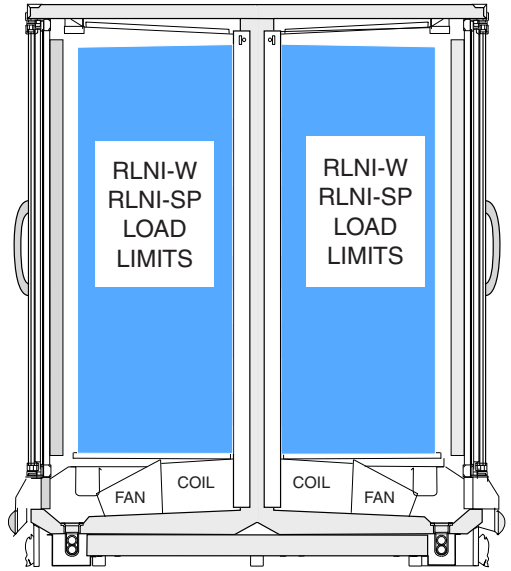
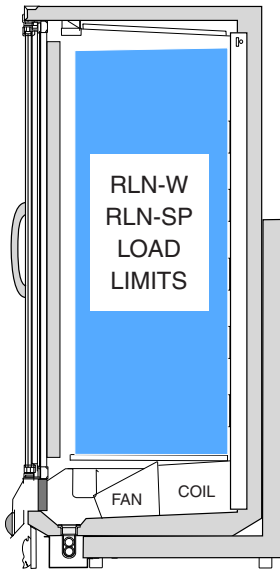

INSTALLING FDA/NSF REQUIRED THERMOMETER

The following pages provide the same information that ships with the thermometer. This requirement does not apply to display refrigerators intended for bulk produce (refer to Page 1-1). Please note that the tape cannot be exposed after installation.

This is an NSF-7 & US FDA Food Code Required Thermometer

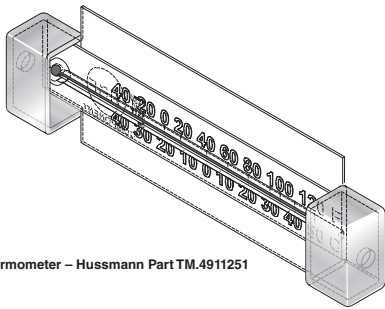

Thermometer – Hussmann Part TM.4911251

Hussmann Corporation • 12999 St. Charles Rock Road • Bridgeton, MO 63044-2483 U.S. & Canada
1-800-922-1919 • Mexico 1-800-890-2900 • www.hussmann.com
© 2007 Hussmann Corporation

Suggested Mounting Locations in Single Deck Glass Front Impact Merchandisers

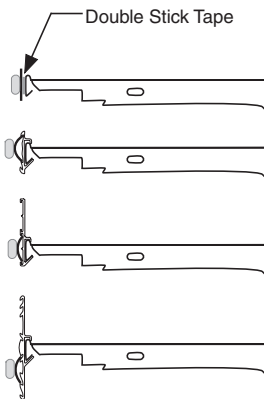
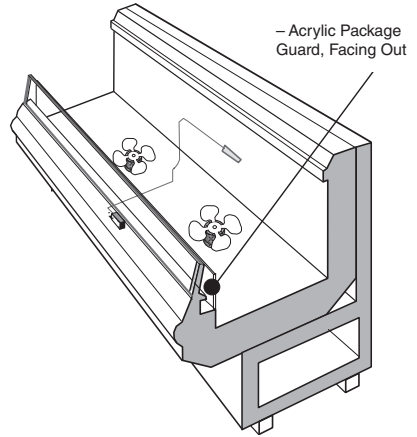

Flexible Plastic Fits in Price Tag Moldings

Hussmann P/N 0429971_C

10/2007

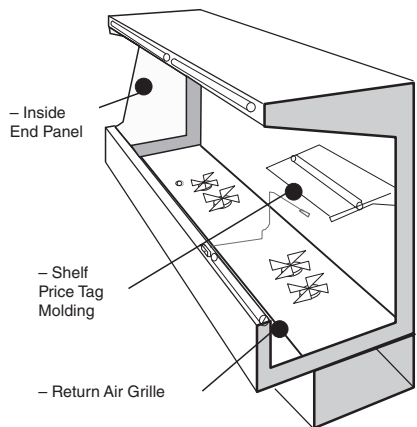

Suggested Mounting Locations in Multi-deck Merchandisers

Important – Please read!

This thermometer is provided in response to United States
Food and Drug Administration (US FDA) Food Code [<http://www.fda.gov/>]
and
National Sanitation Foundation (NSF / ANSI) Standard 7 [<http://www.nsf.org/>]

Each installation will be different depending on how the unit is stocked, shopping patterns in the department and ambient conditions of the store. The suggested locations provided herein are possible locations. It is the responsibility of the purchaser / user to determine the location within the food storage area of the unit that best meets the code requirements above.

The thermometer may need to be moved several times to find the warmest location. Mounting options include flexible plastic for price tag molding application, magnet applied to back of flexible plastic for steel end wall, and double stick tape. Tape must not be exposed after installation.

Questions about either code should be addressed to local agencies or other appropriate officials.

Keep with merchandiser

or give to store manager.

DO NOT DESTROY.

MAINTENANCE

CARE AND CLEANING

Long life and satisfactory performance of any equipment is dependent upon the care it receives. To ensure long life, proper sanitation and minimum maintenance costs, these merchandisers should be thoroughly cleaned, all debris removed and the interiors washed down, weekly.

Fan Plenum

To facilitate cleaning, the fan plenum is hinged and also fastened with screws at each end. After cleaning be sure the plenum is properly lowered into position and that screws are reinstalled OR PRODUCT LOSS WILL RESULT due to improper refrigeration.



WARNING

**SHUT FANS OFF DURING
CLEANING PROCESS.**

Always*Clear™ Glass

Wipe inside of glass with isopropyl alcohol and a soft cloth. Allow surface to dry before closing door. Use of other cleaners or abrasives may damage the Always*Clear surface, and/or void the warranty. Refer to manual that ships with doors.



WARNING

Do NOT use HOT water on COLD glass surfaces. This can cause the glass to shatter and could result in personal injury. Allow glass fronts, ends and service doors to warm before applying hot water.

Interior Surfaces

The interior surfaces may be cleaned with most domestic detergents, ammonia based cleaners and sanitizing solutions with no harm to the surface.

Exterior Surfaces

The exterior surfaces should be cleaned with a mild detergent and warm water to protect and maintain their attractive finish. NEVER USE ABRASIVE CLEANSERS OR SCOURING PADS.

Do Not Use:

- Abrasive cleansers and scouring pads, as these will mar the finish.
- Coarse paper towels on coated glass.
- Ammonia-based cleaners on acrylic parts.
- Solvent, oil or acidic based cleaners on any interior surfaces.



WARNING

Always disconnect the electrical power at the main disconnect when servicing or replacing any electrical component. This includes, but is not limited to, such items as fans, heaters, thermostats and lights.

Do Use:

- Remove the product and all loose debris to avoid clogging the waste outlet.
- Store product in a refrigerated area such as a freezer. Remove only as much product as can be taken to the freezer in a timely manner.
- **First turn off refrigeration, then disconnect electrical power.**
- Thoroughly clean all surfaces with soap and hot water. **DO NOT USE STEAM OR HIGH WATER PRESSURE HOSES TO WASH THE INTERIOR. THESE WILL DESTROY THE MERCHANDISERS' SEALING CAUSING LEAKS AND POOR PERFORMANCE.**
- Remove screws and lift hinged fan plenum for cleaning. **BE SURE TO REPOSITION THE FAN PLENUM AFTER CLEANING MERCHANDISER.**
- Take care to minimize direct contact between fan motors and cleaning or rinse water.
- Rinse with hot water, but do NOT flood. **NEVER INTRODUCE WATER FASTER THAN THE WASTE OUTLET CAN REMOVE IT.**
- Allow merchandisers to dry before resuming operation.
- After cleaning is completed, turn on power and refrigerant to the merchandiser.
- Verify that merchandiser is working properly.



CLEANING HONEYCOMB ASSEMBLIES

Honeycombs should be cleaned every six months. Dirty honeycombs will cause merchandisers to perform poorly. The honeycombs may be cleaned with a vacuum cleaner. Soap and water may be used if all water is removed from the honeycomb cells before reassembling. Be careful not to damage the honeycombs.

1. Remove the sheet metal screws located in the front metal retainer which holds the honeycomb assembly in place.
2. Lift the honeycomb assembly out of the L-bracket to remove it.
3. Clean and dry the honeycomb.
4. After cleaning, reassemble in reverse order of removal.

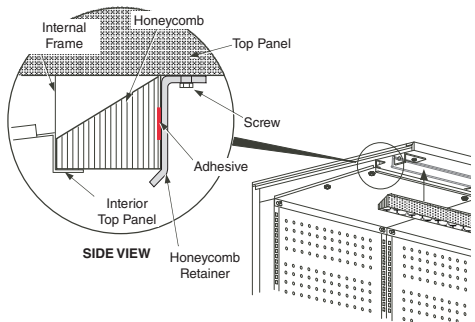

CLEANING STAINLESS STEEL SURFACES

Use non-abrasive cleaning materials, and always polish with grain of the steel. Use warm water or add a mild detergent to the water and apply with a cloth. Always wipe rails dry after wetting.

Use alkaline chlorinated or non-chlorine containing cleaners such as window cleaners and mild detergents. Do not use cleaners containing salts as this may cause pitting and rusting of the stainless steel finish. Do not use bleach.

Clean frequently to avoid build-up of hard, stubborn stains. A stainless steel cleaning solution may be used periodically to minimize scratching and remove stains. Rinse and wipe dry immediately after cleaning. Never use hydrochloric acid (muriatic acid) on stainless steel.

CLEANING COILS

NEVER USE SHARP OBJECTS AROUND COILS.

Use a **soft brush or vacuum brush to clean debris from coils.**

Do not puncture coils!

Do not bend fins. Contact an authorized service technician if a coil is punctured, cracked, or otherwise damaged.

Do NOT use chlorine or ammonia-based cleaners to clean aluminum coils.

ICE in or on the coil indicates the refrigeration and defrost cycle is not operating properly. Contact an authorized service technician to determine the cause of icing, and to make adjustments as necessary. To maintain product integrity, move all product to a cooler until the unit has returned to normal operating temperatures.

WARNING

Do NOT allow cleaning agent or cloth to contact food product.

CLEANING UNDER MERCHANDISERS

Remove splashguards not sealed to floor. Use a vacuum with a long wand attachment to remove accumulated dust and debris from under the merchandiser.

REMOVING SCRATCHES FROM BUMPER

Most scratches and dings can be removed using the following procedure.

1. Use steel wool to smooth out the surface area of the bumper or top rail.
2. Clean area.
3. Apply vinyl or car wax and polish surface for a smooth glossy finish.

NOTES:

SERVICE

Before Beginning Any Service or Repair:

Use a hand-held propane leak detector (“sniffer”) to ensure no propane is present in the immediate area, the inside of the display case and the inside of the refrigeration system. R-290 is an odorless refrigerant. Keep the area clear of all customers and non-essential or unauthorized personnel.

Verify that all repair parts are identical models to the ones they are replacing. Do not substitute parts such as motors, switches, relays, heaters, compressors, power supplies or solenoids. Failure to do so can result in an explosion, death, injury and property damage. Parts used on hydrocarbon cases must meet specific UL certification for non-incendive or non-sparking components. Use only Hussmann approved parts approved through the Hussmann Performance Parts Website. <https://parts.hussmann.com/>

Brazing must not begin before all propane has been cleared from the immediate area — the inside of the displays case and the inside of the refrigeration system.

REPLACING FAN MOTORS AND BLADES

See cross section for location of evaporator fans. Should it ever be necessary to service or replace the fan motors or blades be certain that the fan blades are re-installed correctly.

Fan Access

1. Disconnect power to the case.
2. Remove bottom display pans.
3. Remove plug clip and disconnect fan from wiring harness.
4. Remove fan blade.
5. Remove screws holding fan motor/bracket assembly to plenum and remove assembly.

6. Replace fan motor/bracket assembly and reinstall screws.
7. Reinstall fan blade.
8. Reconnect fan to wiring harness, and replace plug clip.
9. Turn on power.
10. Verify that motor is working and blade is turning in the correct direction.
11. Close large air gaps under fan plenum. Warmer air moving into refrigerated air reduces effective cooling. If the plenum does not rest against the case bottom without gaps, apply foam tape to the bottom of the fan plenum to reduce improper air movement, however defrost water should not be blocked by fan plenum. Do NOT seal fan plenum so that water can not drain.
12. Replace display pans. Bring merchandiser to operating temperature before restocking.

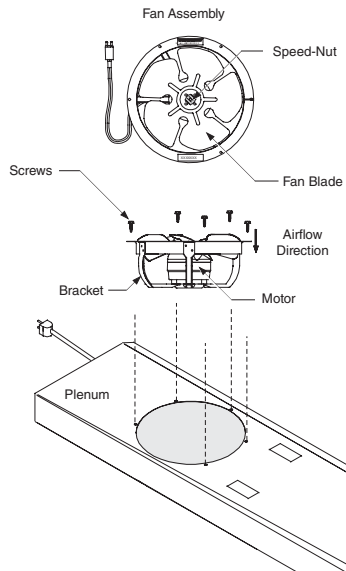

Hussmann recommends against frame heater cycling with Innovator doors to prevent door seals from freezing to the frames and tearing.

REPLACING ELECTRIC DEFROST HEATERS FOR (RL-W / RLN-W / RLNI-W / RLN-SP / RLNI-SP)

Electric defrost requires a heater on the front and rear of the coil as shown. The heaters are held in place by tabs in the coil brackets.

Front Defrost Heater

1. Disconnect power to the case.
2. Lift fan plenum up and back to access the heater.
3. Bend tabs holding heater to horizontal.
4. Remove heater from coil bracket.
5. Position new heater in bracket.
6. Bend tabs back to vertical to hold heater in bracket.
7. Replace the coil cover and lower fan plenum.
8. Turn on power.

Electric Defrost

Bend Tabs on Each Bracket to Release or Secure Heaters

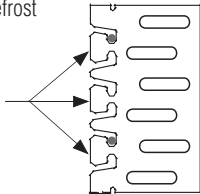

9. Verify that heater is working correctly.
10. Close air gaps under fan plenum. Warmer air moving into refrigerated air reduces effective cooling. If the plenum does not rest against the case bottom without gaps, apply foam tape to the bottom of the fan plenum to reduce improper air movement. Use silicone sealant to close other gaps.
11. Replace display pans. Bring merchandiser to operating temperature before restocking.

Rear Defrost Heater

1. Disconnect Power.
2. Remove coil cover.
3. Remove clips holding heater to coil tube.
4. Remove heater from slots in coil bracket.
5. Position new heater in slots.
6. Replace clips.
7. Replace the coil cover.
8. Turn on power.
9. Verify that heater is working correctly.
10. Replace display pans. Bring merchandiser to operating temperature before restocking.

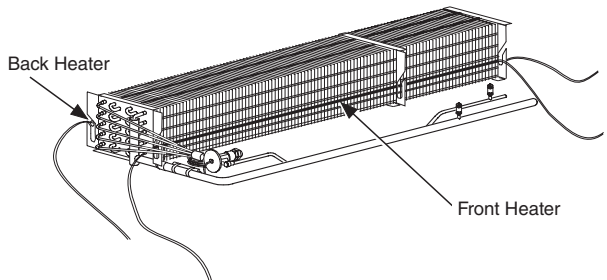
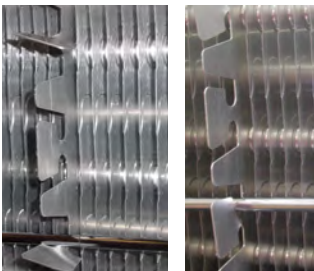

REPLACING Drain Pan Heater — Electric and Gas Defrost (Low Temperature Only)

The drain pan heater is located as shown below.

Remove Drain Pan Heater

1. Disconnect power.
2. Pull heater out from under heater clips.
3. Position new heater under heater clips. Be sure offset is properly positioned around the drain.
4. Reconnect power.
5. Verify that heater is working correctly.

WARNING

Always disconnect the electrical power at the main disconnect when servicing or replacing any electrical component. This includes, but is not limited to, such items as fans, heaters, thermostats and lights.

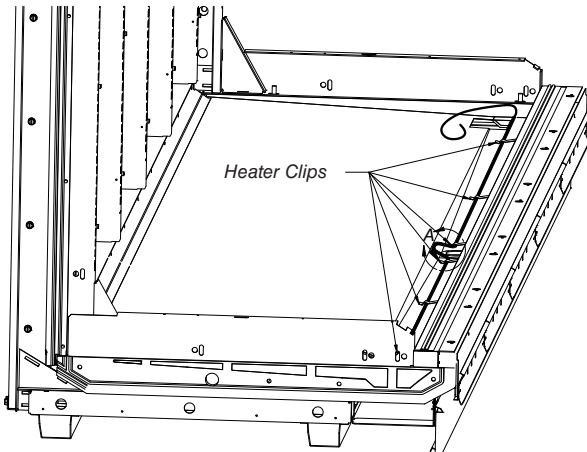
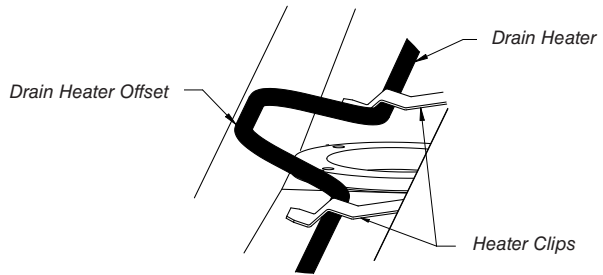

SERVICING VERTICAL LIGHTING

Refer to door manufacturer's manual for servicing of vertical lamps.

SERVICING DOORS AND FRAMES

See door manufacturer's service manual for servicing information. One manual is shipped with each merchandiser.

Hussmann's Innovator Door manual (P/N 0425683) can be found on the website WWW.HUSSMANN.COM.

REPLACING DOOR OR DOOR FRAME PARTS

Parts for Reach-in doors and door frame assemblies must be ordered direct from the door manufacturer. This includes the glass doors, door frame assemblies, lamps, ballasts, door handles, hold open slides, and power cords.

Refer to specific warranty supplied with the door.

The manufacturers have a warranty against moisture penetration, a warranty against tempered glass breakage, and a warranty on ballasts. Lamps are not covered by Hussmann or the door manufacturer.

REPLACING DAMAGED DRAIN FITTING

The following procedure is for the field repair of a broken drain fitting.

1. Use a drill with a 1 7/8-inch (48 mm) hole saw to drill out the bottom of the drain fitting. Be sure to drill completely through fitting and bottom liner.

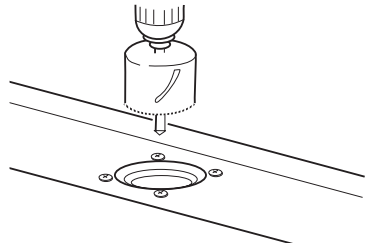

Drain Fitting Viewed from Inside Case

2. Insert adapter into drain fitting. **Do NOT use thread sealer on ABS drain fitting. If sealer is used the ABS drain fitting may crack or leak!** (Tee should be tightened no more than 4 turns.) Do not overtighten threads.

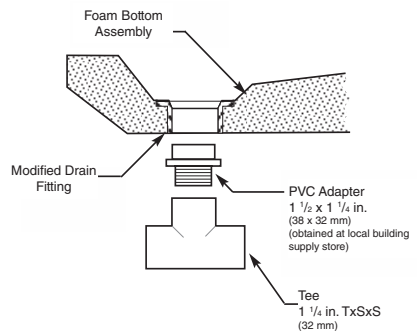

Do NOT use Thread Sealer on Drain Fitting!

End Section View

REPAIRING ALUMINUM COIL

The aluminum coils used in Hussmann merchandisers may be easily repaired in the field. Materials are available from local refrigeration wholesalers.

Hussmann recommends the following solders and technique:

Solders

Aladdin Welding Products Inc.
P.O. Box 7188
1300 Burton St.
Grand Rapids, MI 49507
Phone: 1-800-645-3413
Fax: 1-800-645-3414

X-Ergon
1570 E. Northgate
P.O. Box 2102
Irving, TX 75062
Phone: 1-800-527-9916

NOTE:

Hussmann Aluminum melts at 1125°F (607°C)

Aladdin 3-in-1 rod at 732°F (389°C)

X-Ergon Acid core at 455°F (235°C)

Technique:

1. Locate Leak.
2. REMOVE ALL PRESSURE.
3. Brush area UNDER HEAT.
4. Use PRESTOLITE TORCH ONLY. Number 6 tip.
5. Maintain separate set of stainless steel brushes and USE ONLY ON ALUMINUM.
6. Tin surface around area.
7. Brush tinned surface UNDER HEAT, thoroughly filling the open pores around leak.
8. Repair leak. Let aluminum melt solder, NOT the torch.
9. Don't repair for looks. Go for thickness.
10. Perform a leak check.
11. Wash with water.
12. Cover with a good flexible sealant.



HUSSmann®

To obtain warranty information
or other support, contact your
Husmann representative.
Please include the model and serial
number of the product.