

HUSSMANN®



LBN

*Low Temperature
Horizontal Merchandiser*



*Installation &
Operation Manual*

IMPORTANT
Keep in store for future reference!

P/N 0514392_G
October 2014

MANUAL - I/O SC LBN

Spanish 0531293
French 0531294

ATTENTION

Merchandiser must operate for 24 hours
before loading product!

Regularly check merchandiser temperatures.

Do not break the cold chain. Keep products
in cooler before loading into merchandiser.

These merchandisers are designed
for pre-frozen products only.



IMPORTANT
KEEP IN STORE FOR FUTURE REFERENCE
Quality that sets industry standards!

12999 St. Charles Rock Road • Bridgeton, MO 63044-2483

U.S. & Canada 1-800-922-1919 • Mexico 1-800-890-2900

www.husmann.com

© 2014 Husmann Corporation

TABLE OF CONTENTS

v

ANSI DEFINITIONS	vi	START UP / OPERATION	
INSTALLATION		Start-Up	3-1
Certification	1-1	Controls and Adjustments	3-1
Hussmann Product Control	1-1	Load Limits	3-2
Shipping Damage	1-1	Stocking	3-2
Location	1-1	Thermometer	3-2
Self Contained Location	1-2		
Model Description	1-3	MAINTENANCE	
Unloading	1-3	Care and Cleaning	4-1
Exterior Loading	1-3	Do NOT Use:	4-1
Shipping Skid	1-3	Do:	4-1
Merchandiser Leveling	1-4	Cleaning Discharge Air Grille	4-2
Compressor	1-4	Cleaning Solar Thermometer	4-2
Optional Legs	1-4	Cleaning Coils	4-2
Serial Plate Location	1-4	Cleaning Under Display Pan	4-2
Refrigeration Unit Access	1-5	Cleaning Evaporator Pan	4-3
Drain Trap	1-5	Cleaning Stainless Steel Surfaces	4-3
Sealing Merchandiser to Floor	1-5	Removing Scratches from Bumper	4-4
NOTES	1-6		
		SERVICE	
ELECTRICAL / REFRIGERATION		Defrost Thermostat Replacement	5-1
Merchandiser Electrical Data	2-1	Defrost Heater Replacement	5-1
Field Wiring	2-1	Condensate Heaters	5-2
Electrical Connections	2-1	End Panel Heaters	5-2
Power Switch	2-1	Replacing Fluorescent Lamps / Ballasts ..	5-2
Electrical Box	2-1	Front Glass Heater Replacement	5-3
Electrical Outlet	2-2	Nose Heater Replacement	5-3
Refrigeration (Self Contained)	2-2	Condensate Heater Limit Thermostat ...	5-3
Refrigeration (Remote)	2-2	Troubleshooting Guide	5-4
Line Sizing	2-3	Light Problem / Solution	5-6
Waste Outlet and Water Seal	2-3	LBN Accessories and Options	5-7
Safe-NET III Control	2-3	Compressor Replacement Procedure	5-8
Safe-NET User Instructions	2-4	Internal Leak Warranty Policy	5-8
Sequence of Operation	2-6		
Dual Temperature Sequence of Operation	2-7	Table of Contents Continued on Next Page ...	
Temperature Adjustment	2-8		
Electromechanical Controls	2-3		
Defrost Time Clock	2-3		
Setting Defrost Times	2-4		
Crankcase Pressure Regulator	2-4		

TABLE OF CONTENTS CONTINUED

APPENDIX

Part Numbers A-1
 Plan View A-4
 Cross Section and Refrigeration Data... A-5
 Electrical Data A-6
 Wiring Diagrams A-7

REVISION HISTORY

REVISION G — changed pages:1-5, 2-1, 2-3, moved pages 2-4 - 2-11 to Page 3-2, 2-5, 3-1, 5-7 removed plug 2-2; removed parameter codes, 3-4 Added California Prop 65 Warning; new wiring diagrams and parts list, Section A

REVISION F — Removed all references to Ice Cream

REVISION E — Replaced LBN-10 Wiring Diagram; added Page A-11, 230V

REVISION D — Revised Wiring Diagrams

REVISION C — Revised incorrect part number for LBN-4 Compressor, Page A-2, **OCTOBER 2011**

REVISION B — Changed for Windchill purposes

ORIGINAL ISSUE — **DECEMBER 2010**

ANSI Z535.5 DEFINITIONS



- **DANGER** – Indicate[s] a hazardous situation which, if not avoided, will result in death or serious injury.



- **WARNING** – Indicate[s] a hazardous situation which, if not avoided, could result in death or serious injury.



- **CAUTION** – Indicate[s] a hazardous situation which, if not avoided, could result in minor or moderate injury.

- **NOTICE** – *Not related to personal injury* – Indicates[s] situations, which if not avoided, could result in damage to equipment.

INSTALLATION

CERTIFICATION

These merchandisers are manufactured to meet ANSI / National Sanitation Foundation (NSF®) Standard #7 requirements. Proper installation is required to maintain certification. Near the serial plate, each case carries a label identifying the type of application for which the case was certified.

ANSI/NSF-7 Type I - Display Refrigerator / Freezer

Intended for 75°F / 55% RH Ambient Application

ANSI/NSF-7 Type II - Display Refrigerator / Freezer

Intended for 80°F / 55% RH Ambient Application

ANSI/NSF-7 - Display Refrigerator

Intended for Bulk Produce

HUSSMANN PRODUCT CONTROL

The serial number and shipping date of all equipment is recorded in Hussmann's files for warranty and replacement part purposes. All correspondence pertaining to warranty or parts ordering must include the serial number of each piece of equipment involved. This is to ensure the customer is provided with the correct parts.

SHIPPING DAMAGE

All equipment should be thoroughly examined for shipping damage before and during unloading. This equipment has been carefully inspected at our factory. Any claim for loss or damage must be made to the carrier. The carrier will provide any necessary inspection reports and/or claim forms.

Apparent Loss or Damage

If there is an obvious loss or damage, it must be noted on the freight bill or express receipt and signed by the carrier's agent; otherwise, carrier may refuse claim.

Concealed Loss or Damage

When loss or damage is not apparent until after equipment is uncrated, retain all packing materials and submit a written response to the carrier for inspection within 15 days.

LOCATION

These merchandisers are designed for displaying products in air conditioned stores where temperature is maintained at or below the ANSI / NSF-7 specified level and relative humidity is maintained at or below 55%.

Recommended operating ambient temperature is between 65°F (18°C) to 75°F (23.9°C). Maximum relative humidity is 55%.

Placing refrigerated merchandisers in direct sunlight, near hot tables or near other heat sources could impair their efficiency. Like other merchandisers, these merchandisers are sensitive to air disturbances. Air currents passing around merchandisers will seriously impair their operation. Do NOT allow air conditioning, electric fans, open doors or windows, etc. to create air currents around the merchandiser.

SELF CONTAINED (LOCATION)

LBN-4, 6, 7 and 8 each have front condenser air intake and discharge. Maintain a minimum clearance distance of two feet in front of the merchandiser so that air discharge and air intake is not obstructed.

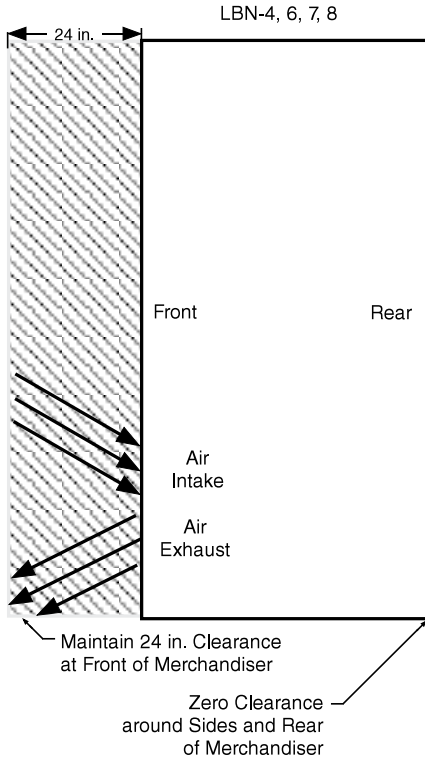

LBN-10 requires a 2 inch minimum clearance behind the merchandiser. A 24 in. clearance must be maintained in front of the merchandiser, because air flows through the front condensing unit compartment.

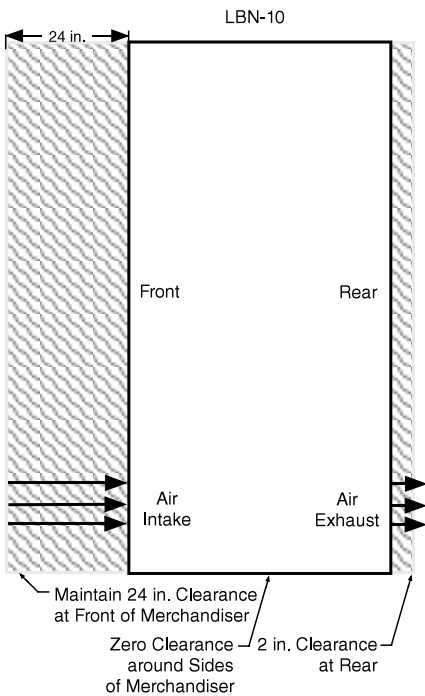

For California Businesses:

! WARNING

This product may contain chemicals known to the State of California to cause cancer, birth defects, or other reproductive harm.

This warning is the result of the California State law known as the California Safe Drinking Water and Toxic Enforcement Act of 1986, which is commonly referred to as "Proposition 65."

This warning does not mean that Hussmann products will cause cancer or reproductive harm, or is in violation of any product-safety standards or requirements. As clarified by the California State government, Proposition 65 can be considered more of a 'right to know' law than a pure product safety law. When used as designed, Hussmann believes that our products are not harmful. We provide the Proposition 65 warning to stay in compliance with California State law. It is your responsibility to provide accurate Proposition 65 warning labels to your customers when necessary. For more information on Proposition 65, please visit the California State government website.

MODEL DESCRIPTION

The LBN series are low temperature, self-contained cabinets designed for pre-packaged foods at below freezing temperatures. Design features include non-heated glass lids, foamed in place non-CFC insulation, interior mirrors, reflectors, front-air discharge condensing unit, (except LBN-10) and a balanced refrigeration system for energy-saving performance.

UNLOADING

Unloading from Trailer:

Use a Lever Bar (also known as a Mule, Johnson Bar, J-bar, Lever Dolly, or Pry Lever).

Move the merchandiser as close as possible to its permanent location and remove all packaging. Check for damage before discarding packaging. Remove all separately packed accessories such as kits and shelves.



Improper handling may cause damage to the merchandiser when unloading. To avoid damage:

1. Do not drag the merchandiser out of the trailer. Use a Johnson bar (mule).
2. Use a forklift or dolly to remove the merchandiser from the trailer.



EXTERIOR LOADING

Do NOT walk on top of merchandisers or damage to the merchandisers and serious personal injury could occur.

MERCHANDISERS ARE NOT STRUCTURALLY DESIGNED TO SUPPORT EXTERNAL LOADING such as the weight of a person. Do not place heavy objects on the merchandiser.

SHIPPING SKID

Each merchandiser is shipped on a skid to protect the merchandiser's base, and to make positioning the case easier.

Do not remove the shipping skid until the merchandiser is near its final location. The skid provides protection for both the merchandiser and the floor.

Remove the skid by raising one end of the merchandiser approximately 6 inches. Block the merchandiser securely, and remove the two skid bolts from the raised end. Replace the bolts with (provided) leg levelers. Repeat this procedure at opposing end. Once the leg levelers are secured in place, the merchandiser may be slid off the skid and placed in its final location.

DO NOT TILT MERCHANDISER ON ITS SIDE OR END WHEN REMOVING SKID.

Once the skid is removed, the merchandiser must be lifted —NOT PUSHED— to reposition.

Check floor where merchandisers are to be set to see if it is a level area. Determine the highest part of the floor.

1-4 INSTALLATION

MERCHANDISER LEVELING

BE SURE TO POSITION MERCHANDISERS PROPERLY. Level the merchandiser by all four corners. Merchandiser(s) must be installed level to ensure proper operation of the refrigeration system, and to ensure proper drainage of defrost water. A slight pitch from front to back is desirable. The cabinet back should never be higher than the front.

COMPRESSOR

The compressor is banded for shipping. Remove the two bolts holding the compressor bar in place. Pull out the condensing unit.

Cut the steel band, which holds down the compressor during shipment. The compressor should now float freely on the mounting springs. **DO NOT LOOSEN NUTS.**

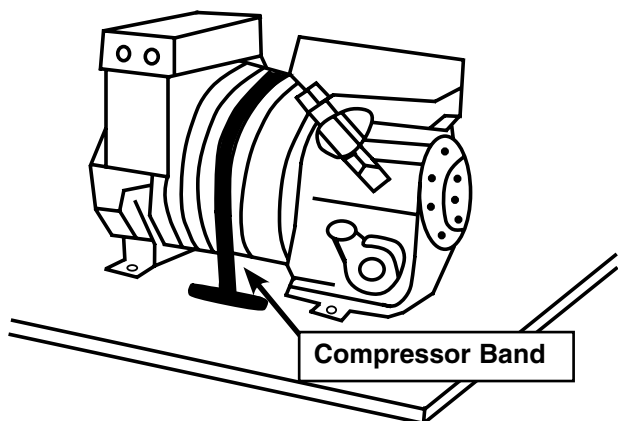

Compressor Band Must Be Cut
(Except for LBN-4)

OPTIONAL LEGS

NSF® approved legs replace the leg levelers if required by local health codes. The legs raise the case 6 inches for cleaning purposes. An optional skirt kit can be provided to snap on the legs.

SERIAL PLATE LOCATION

The serial plate is located on the left-hand end of the case interior, and a second one in the condensing unit compartment. The serial plate contains all pertinent refrigeration and electrical information. The serial plate should not be removed for any reason.



REFRIGERATION UNIT ACCESS

The louvered access panel on the lower right front of the cabinet provides access to the condensing unit and electrical box.



There is also a rear access panel that covers the rear of the condensing unit compartment. This panel can be removed to gain access to the back compartment.

Rear Access Panel Removed



WARNING

— LOCK OUT / TAG OUT —

To avoid serious injury or death from electrical shock, always disconnect the electrical power at the main disconnect when servicing or replacing any electrical component. This includes, but is not limited to, such items as doors, lights, fans, heaters, and thermostats.

DRAIN TRAP

Drain Trap may be accessed by removing the rear access panel that covers the rear of the compressor compartment.

The drain trap should be filled with water.

This

prevents warm air from migrating back through the drain to the evaporator coil.

Failure to fill the trap with water, could result in excessive frosting of the evaporator coil.

For the LBN-10, the back panel is a metal rear panel with slots, which allows discharge air to flow through the condensing unit compartment. Before removing this panel, make sure the power supply to the cabinet is disconnected.

SEALING MERCHANDISER TO FLOOR

If required by local sanitary codes, or if the customer desires, merchandisers may be sealed to the floor using a vinyl cove base trim. The size needed will depend on how much variation there is in the floor, from one end of the merchandiser to the other. Sealing of the lower front and rear panels on self contained models may hamper their removal for servicing or maintenance of the condensing unit.

NOTE: Do not allow trim to cover any intake or discharge grilles located in the lower front panel.

1-6 INSTALLATION

NOTES:

ELECTRICAL / REFRIGERATION

MERCHANDISER ELECTRICAL DATA

Refer to Appendix A of this manual or the merchandiser's serial plate for electrical information.

FIELD WIRING

Field wiring must be sized for component amperes stamped on the serial plate. Actual ampere draw may be less than specified.

ALWAYS CHECK THE SERIAL PLATE FOR COMPONENT AMPERES

ELECTRICAL CONNECTIONS

LBN-4, 6, 7 and 8 models have a power cord attached to the unit with a ground prong. The cord is rated 115V/15Amp. The LBN-7 and 8 also require a circuit breaker or a time delay fuse rated at 15 Amps for the circuit being run to them. The LBN-10 has both a 115V & 208/230V circuit. The LBN-10 is hard wired, and connections are made in 2 x 4 handy box.

All of these models are 60 hz, 1 ph. Connecting this unit to any electrical supply other than specified on the serial plate will void the warranty and may result in serious damage to the unit. The cabinet should be supplied with its OWN service.



WARNING

**Merchandiser must be grounded.
Do not remove the power supply cord ground.**

POWER SWITCH

The power switch is located at the electrical box that is behind the front, louvered access panel. A slot in one of the louvers allows access to the switch. The switch will shut off all power to the cabinet for all LBN models.



Power Switch

ELECTRICAL BOX (Control Options)

LBN 4,6,7,8 models have 2 control options. The standard option uses electro-mechanical controls, consisting of a timer / defrost clock, thermostat and power switch.

An optional electronic SNIII control, display, and compressor & defrost power relays. Both options are located in the electrical box. This box is capable of sliding out for servicing convenience. Access is gained by removing the cover on the side of the box.

2-2 ELECTRICAL / REFRIGERATION

ELECTRICAL OUTLET:

Before the merchandiser is connected to any wall circuit, use a voltmeter to check that the outlet is at 100% of the rated voltage. The wall circuit must be dedicated for the merchandiser. Failure to do so voids the warranty. Do not use an extension cord. Never plug in more than one merchandiser per electrical circuit.

- Always use a dedicated circuit with the amperage stated on the unit.
- Plug into an outlet designed for the plug.
- Do not overload the circuit
- Do not use long or thin extension cords. Never use adapters.
- If in doubt, call an electrician.

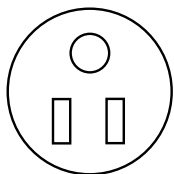

NEMA 5-15R Receptacle
All Models Except LBN-10

LBN-10 is hard wired - no power cord.

REFRIGERATION (Self Contained Models)

Each self contained model is equipped with its own condensing unit and control panel located beneath the display area. The correct type of refrigerant will be stamped on each merchandiser's serial plate. The merchandiser refrigeration piping is leak tested. The unit is charged with refrigerant, and shipped from the factory with all service valves open.

LBN-6, 7, 8 and 10 models have a refrigeration system that uses a semi-hermetic compressor. LBN-4 uses a hermetic compressor. LBN systems use a capillary tube for refrigerant control. The capillary tube is soldered to the suction line pull-out coil for proper heat exchange. **If the capillary should become plugged or damaged, it is best to replace the heat exchanger.**

CAUTION

**Refrigeration lines are under pressure.
Refrigerant must be recovered before
attempting any connection or repair.**

WARNING

Risk of Electric Shock. If cord or plug becomes damaged, replace only with a cord and plug of the same type.



**It is the contractor's responsibility to
install merchandiser(s) in accordance with
all local building and health codes.**

WATER OUTLET AND WATER SEAL

The condensate water outlet is located on the rear right side of the merchandiser. The outlet has a factory installed, external water seal.

Attached to the water seal or external drain is a black rubber drain hose. At the end drain hose is a copper water trap. This water trap drains into the condensate evaporator pan located beneath the merchandiser. **Ensure the drain hose is properly trapped, and the drain area is not clogged.**

NOTE: All lower base panels must be in place when the refrigerator is operating. If not, air-flow from the condenser will be directed over the evaporator pan and defrost water in the pan may overflow.

REFRIGERATION CONTROLS

These merchandisers come standard with electromechanical temperature control and time clock. Defrosts are time-initiated and temperature terminated. Optional electronic controls are available.

ELECTROMECHANICAL CONTROLS

To access the defrost time clock, remove the front access panel, and remove the electrical box cover.

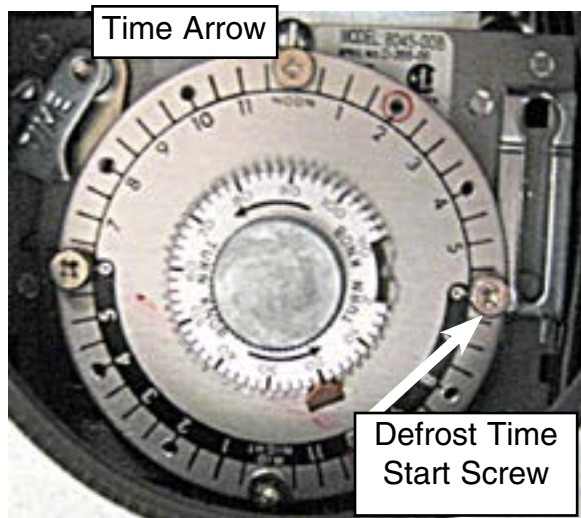

The clock has screws that initiate defrost according to the time of day. The failsafe setting sets the length of defrost from two minutes to 110 minutes.

To ensure a through defrost, it may be necessary to increase the failsafe time in high ambient conditions.

The time arrow must be set to the correct time of day. Turn the knob until the appropriate time on the wheel lines up with the time arrow.

**WARNING**

— LOCK OUT / TAG OUT —

To avoid serious injury or death from electrical shock, always disconnect the electrical power at the main disconnect when servicing or replacing any electrical component. This includes, but is not limited to, such items as doors, lights, fans, heaters, and thermostats.

CRANKCASE PRESSURE REGULATOR

The LBN series employs a crankcase pressure regulator in the same suction line and is considered part of the heat exchanger. The CPR is set to 10 psig. The purpose of the valve is to maintain a low suction pressure on start-up so that the compressor will start properly.

On start-up, the valve will hold the suction pressure at the desired setting until the suction pressure has dropped below the setting, then the valve will open.

If it becomes necessary to check or reset the setting, the merchandiser must be warm such as after a defrost cycle or from an initial warm interior cabinet condition.

Put a suction compound gauge on the compressor suction valve. Start the compressor. If the pressure needs to be reduced, turn the adjustment screw clockwise to raise the pressure.

Do not set the valve based on the serial plate amperage rating, because the pressure setting will be too high, and the compressor will not start properly.

**WARNING**

Product will be degraded and may spoil if allowed to sit in a non-refrigerated area.

START UP / OPERATION

START UP — ELECTROMECHANICAL CONTROL

Follow the electromechanical controls start up procedures as detailed in Section 2 of this manual. Each self contained merchandiser has its own evaporator coil. LBN models have capillary tubes.

- a. Check the interior cabinet thoroughly for loose nuts, bolts and electrical connections.
- b. Inspect the refrigeration lines for visible damage or chafing.
- c. Replace electrical box cover and access panel.
- d. Turn on the electrical power, power switch and start the merchandiser. The merchandiser must pull down in temperature.



COMPRESSOR

Cut the steel band, which holds down the compressor during shipment. The compressor should now float freely on the mounting springs. **DO NOT LOOSEN NUTS.** (LBN-4 HAS NO COMPRESSOR BAND)

NOTE: Failure to cut compressor shipment band may result in excessive noise or system damage, which is not covered by warranty.

CONTROLS and ADJUSTMENTS (All Controls)

Refrigeration Controls		Defrost Controls			
Model	Product Application	Defrost Frequency (per day)	Type of Defrost	Temp. Termination	Failsafe Time (Minutes)
LBN-4, 6, 7, 8 (Self Contained)	Low Temp.	1 Every 48 Hours	Electric	48	40
LBN-10 (Self Contained)	Low Temp.	1 Every 24 Hours	Electric	48	40

Allow merchandiser 24 hours to operate before loading product.

1. The T-stat controller controls refrigeration temperature. This is factory installed in the control panel.

Defrosts are time initiated and temperature terminated for self contained. The defrost setting is factory set as shown above.

LOAD LIMITS

Each merchandiser has a load limit decal. Shelf life of perishables will be short if load limit is violated.



AT NO TIME SHOULD MERCHANDISERS BE STOCKED BEYOND THE LOAD LIMITS INDICATED.

DO NOT BLOCK AIR GRILLE.

STOCKING

Product should NOT be placed inside the merchandisers until merchandisers are at proper operating temperature.

Allow merchandiser 24 hours to operate before loading product.

Proper rotation of product during stocking is necessary to prevent product loss. Always bring the oldest product to the front and set the newest to the back.

AIR DISCHARGE FLUES MUST REMAIN OPEN AND FREE OF OBSTRUCTION AT ALL TIMES to provide proper refrigeration and air curtain performance. Do not allow product, packages, signs, etc. to block the grille. Do not use non-approved shelving, baskets, display racks, or any accessory that could hamper air curtain performance.

Do not allow product to be placed outside of the designated load limits in the illustration at right.

THERMOMETER

The cabinet has a thermometer located on the left-hand end of the nose screen that is just below the upper mirror reflector and light fixture. The thermometer is a “pencil” type and reads from -40° F to 80° F on 2° increments. To replace, remove the two screws and install the replacement.

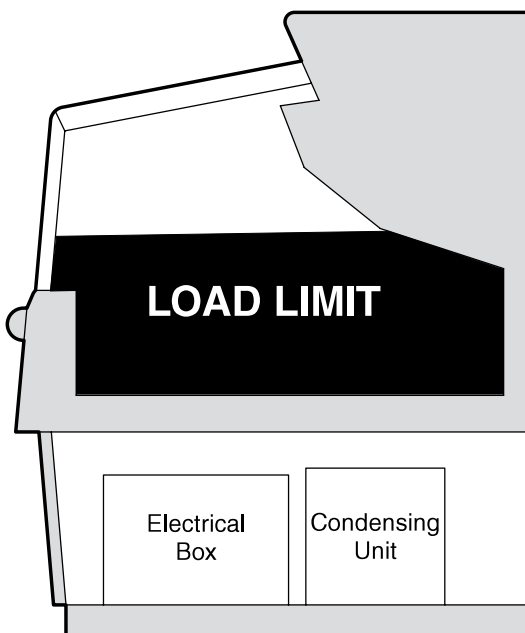

Do not load merchandiser with product above load limit.

**Safe-III™
TEMPERATURE AND DEFROST
CONTROLLER**

SAFE-NET III™ USER INSTRUCTIONS

Your refrigerated case uses a Hussmann Safe-NET™ III temperature and defrost controller to precisely maintain the temperature and prevent frost buildup on the cooling coil. LEDs indicate when the compressor or refrigeration is on, when the case is in a defrost cycle, if the temperature is outside the desired range, or if there is a sensor failure.

An adjustment knob allows the temperature to be set within the configured range and can power off the controller and compressor. Your controller has been custom-configured to provide the best temperature and defrost control for your chilled or frozen food.

The front of the controller has an adjustment knob and status LEDs. The back of the controller has connections for sensors and switched equipment.



The Safe-NET III controller includes the following features and connections.

- Adjustment knob:
Adjusts the temperature setpoint.
Turn adjustment knob to OFF to turn off refrigeration system. Unplug merchandiser from power before servicing the unit.

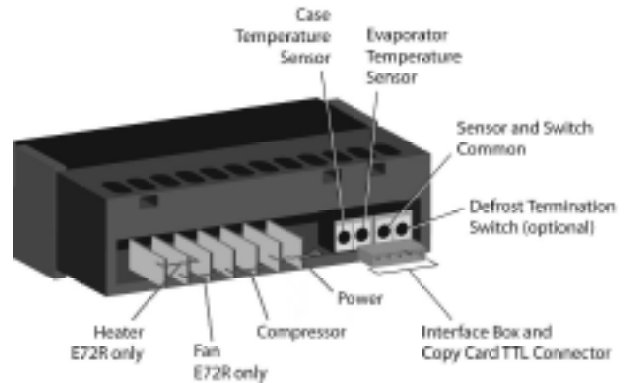

- Controller LEDs:
 - ❄️ Compressor Powered On LED (green):
Lights while the compressor is running or the refrigeration valve is open.
 - ❄️ Defrost Cycle LED (yellow):
Lights while the refrigeration coil is defrosting.
 - 🔊 Temperature or Sensor Alarm (red):
Lights if the temperature is too warm or too cold. Flashes if a sensor fails.



WARNING

Product will be degraded and may spoil if allowed to sit in a non-refrigerated area.

- Rear connections:
 - Case temperature sensor:
 - Typically senses the temperature of the air in the case.
Used by the controller to determine when to power on or power off the compressor or refrigeration.
 - Evaporator temperature sensor:
 - Senses the temperature of the refrigeration coil.
Terminates a defrost cycle when refrigeration coil ice melts.
 - Compressor or refrigeration relay:
 - Switches on the compressor or refrigeration valve for cooling.
 - Defrost / reversing condenser switch
 - Switches on the defrost or reversing condenser fan motor - when used with the condenser fan motor option.

! WARNING

The optional evaporator fan remains ON when the adjustment knob is in the OFF position.

DISPLAY

The display includes three red LEDs and two digits for temperature, defrost status, and error codes.

The three display LEDs are red, and their behavior matches the LEDs on the controller.

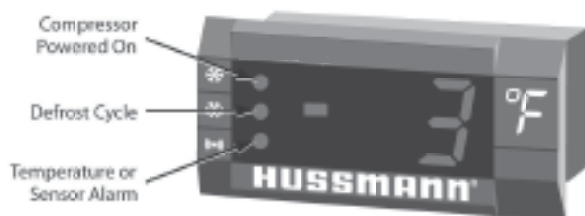

START-UP

1. Plug in the merchandiser.

! WARNING

The OFF Position does not disconnect line voltage to the case, refrigeration unit, fan, or heater.

NOTE: The 65°C Version Controller includes a Parameter Code Number. This number indicates what program has been loaded into the controller. When the Controller is first powered up or is turned off and then back on a 2 digit Parameter Code Number will display for 3 seconds. Then the Self Check will Start.

2. Wait for the self check to complete. During the self check, each LED flashes for one second, then all LEDs turn on for two seconds. If the LEDs do not flash, make sure the adjustment knob is not in the Off position.
 - After the self check, all LEDs turn off until the compressor starts. **There may be a delay before the compressor starts.** If the red Temperature or Sensor Alarm LED stays on after the self check.
 - The green Compressor Powered On LED turns on when the compressor starts.

NOTE: Do NOT load product until AFTER merchandiser operates for 24 hours and reaches desired operating temperature.

Safenet III Parameter Codes

**LBN-4,6,7,8 Code 64
LBN-4,6,7,8 Dual Temp Code 66**

SEQUENCE OF OPERATION LBN

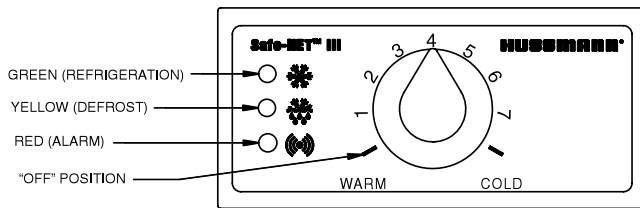
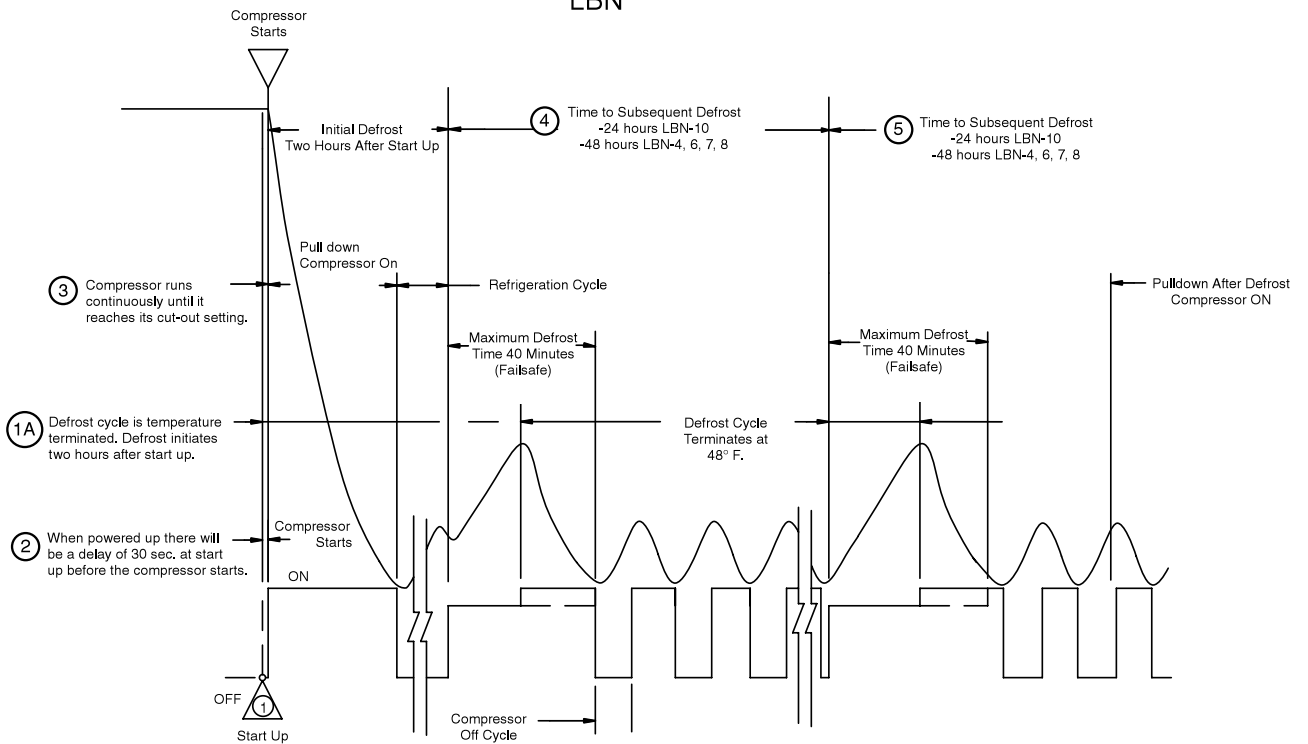

Safe-Net III Controller

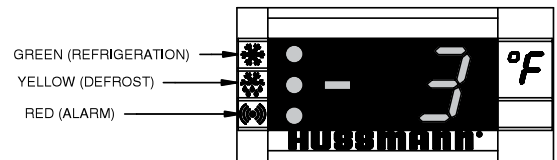

DISPLAY

1. Apply power to the merchandiser. Wait for the self check to complete. During the self check, each LED flashes for one second and then all LEDs turn on for two seconds. If the LEDs do not flash, make sure the adjustment knob is not in the “OFF” position.
- 1A. The merchandiser temperature displays at startup. The initial defrost starts two hours later. The display will show the temperature at the start of defrost. This reading will remain displayed during defrost and until it times out, even though the refrigeration mode has been initiated. (The green LED will be lit.)
2. The compressor will start after a 1-minute delay once power is applied.
3. The compressor will continue to run until it reaches its cut-out temperature (Pulldown).
4. The refrigeration cycle will continue for the next subsequent scheduled (6-hours) or demand defrost. The digital display will display the temperature reading for 10 minutes after defrost.
5. The above process will repeat (steps 3 and 4) until the power is interrupted.
6. If power stops, the process will start over at step 1, and the time to subsequent defrost will reset.

SEQUENCE OF OPERATION
LBN Dual Temperature

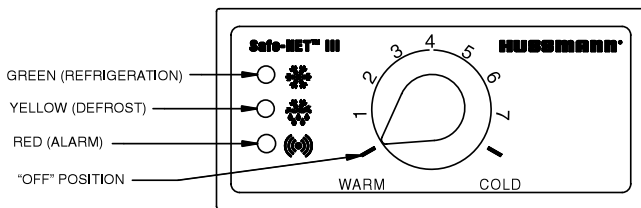
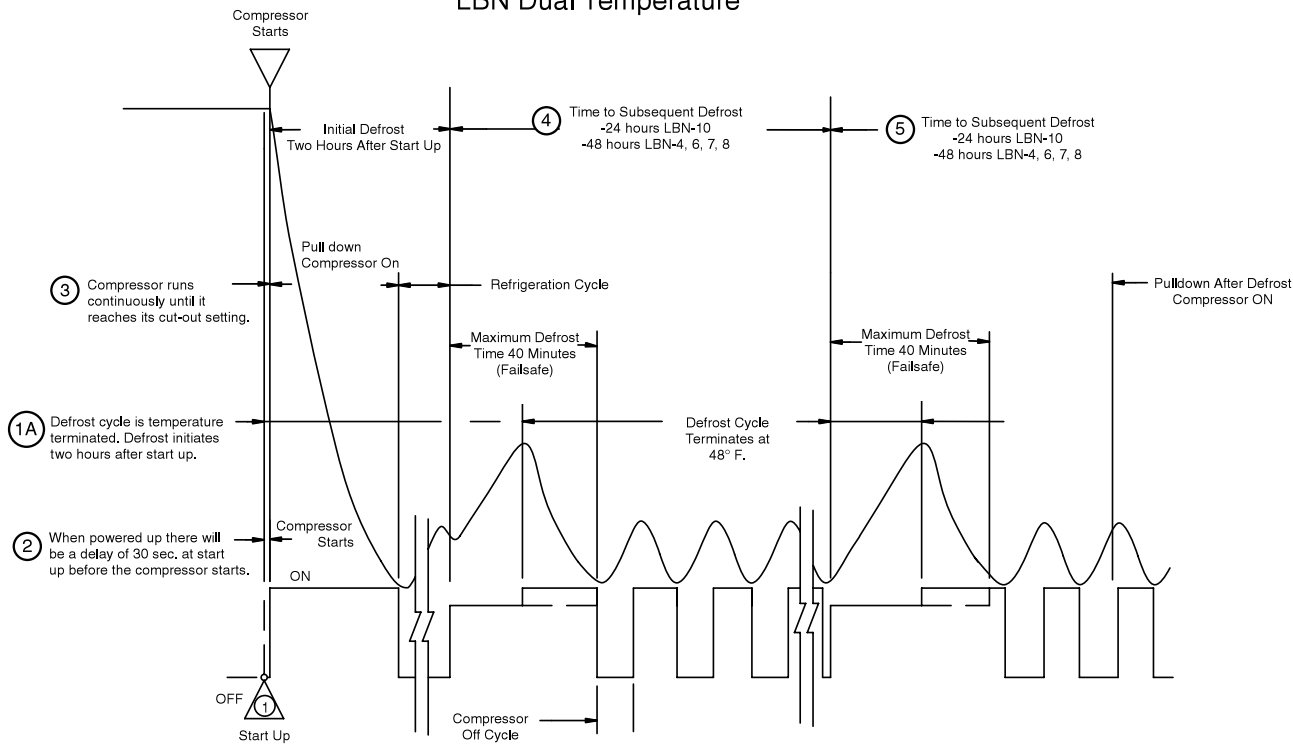

Safe-Net III Controller

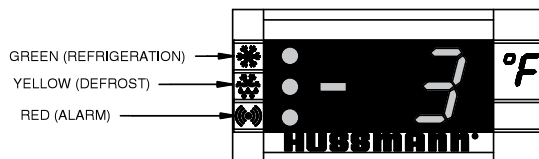

DISPLAY

1. Apply power to the merchandiser. Wait for the self check to complete. During the self check, each LED flashes for one second and then all LEDs turn on for two seconds. If the LEDs do not flash, make sure the adjustment knob is not in the "OFF" position.
- 1A. The merchandiser temperature displays at startup. The initial defrost starts two hours later. The display will show the temperature at the start of defrost. This reading will remain displayed during defrost and until it times out, even though the refrigeration mode has been initiated. (The green LED will be lit.)
2. The compressor will start after a 1-minute delay once power is applied.
3. The compressor will continue to run until it reaches its cut-out temperature (Pulldown).
4. The refrigeration cycle will continue for the next subsequent scheduled (6-hours) or demand defrost. The digital display will display the temperature reading for 10 minutes after defrost — 48 hours for LBN-4, 6, 7, 8.
5. The above process will repeat (Steps 3 and 4) until the power is interrupted.
6. If power stops, the process will start over at Step 1, and the time to subsequent defrost will reset.

TEMPERATURE ADJUSTMENT

Rotate the adjustment knob counter clockwise for a warmer setpoint or clockwise for a colder setpoint.

- While the temperature is being adjusted, the optional display shows the setpoint (cut out value). A few seconds after the temperature is set, the display reverts to showing the sensed temperature in the merchandiser.

ALARMS AND CODES

FLASHING TEMPERATURE OR SENSOR ALARM LED, E1 OR E2

If the Temperature or Sensor Alarm LED (red) on the controller and display is flashing, a temperature sensor has failed. The display shows E1 if the case sensor has failed or E2 if the evaporator sensor has failed.



If the merchandiser sensor fails, refrigeration will run continuously. Turn off, or repeat a duty cycle of a few minutes on and a few minutes off.

DEFROST TERMINATION SWITCH

Merchandisers may use a defrost termination switch, instead of an evaporator sensor to terminate a defrost cycle. The defrost termination switch is temperature activated and senses the completion of defrost.

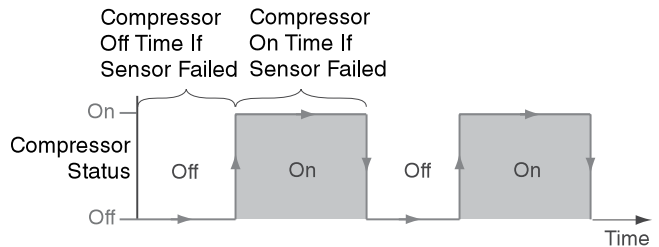

MANUAL DEFROST

Note:

This procedure initiates a manual or forced defrost.

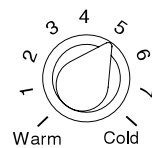

1. Note location of knob setting

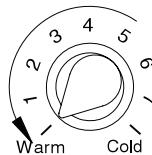

2. Rotate knob fully counterclockwise until it stops (full warm - "OFF" position)

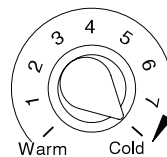

3. After 10 seconds, but before 20 seconds, rotate knob fully clockwise until it stops (full cold position)

IMPORTANT: Return the control knob to its original setting (Step 1) once the manual defrost has been initiated.

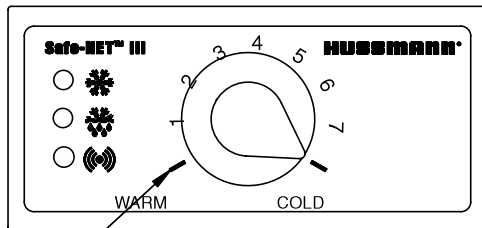

"OFF" Position

Safe-NET III Control
Set at Full Cold Position

Cut out Warm / Cut out Cold

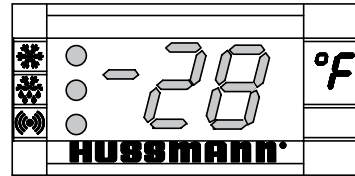

Display - at Full Cold
Model LBN

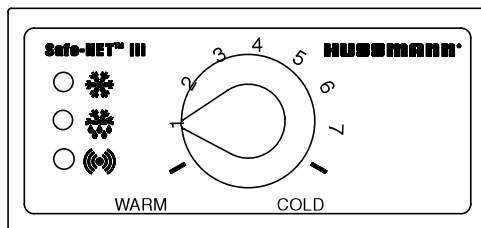

Safe-NET III Control
1 Position

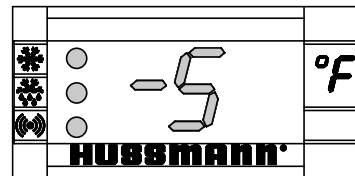

Display - at #1 Position
Model LBN

TEMPERATURE ADJUSTMENT

1. Rotate the adjustment knob counter clockwise for a warmer setpoint or clockwise for a colder setpoint.
2. While adjusting the temperature, the display shows the setpoint (cut out value). A few seconds after the temperature is set, the controller reverts to the sensed temperature in the merchandiser.
3. To verify merchandiser settings, turn the dial to warm and cold as shown above. Output readings should be within one degree of the temperatures shown above.

Dual Temperature

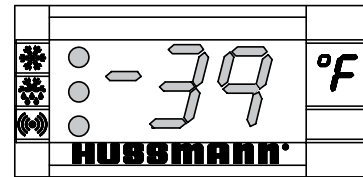
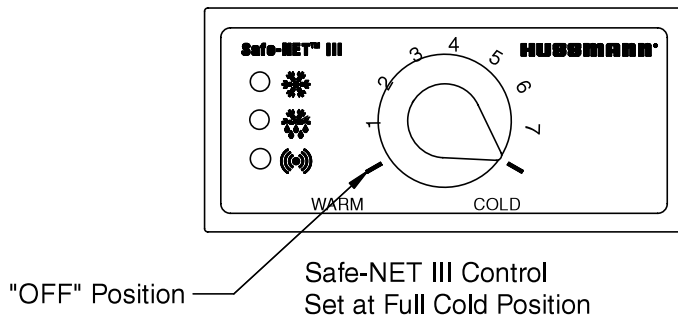

Display - at Full Cold
Model LBN

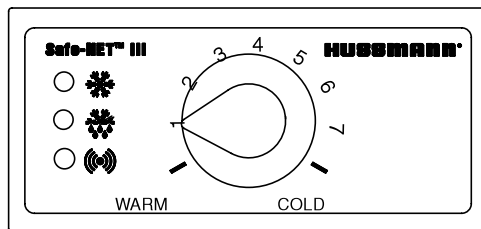

Safe-NET III Control
1 Position

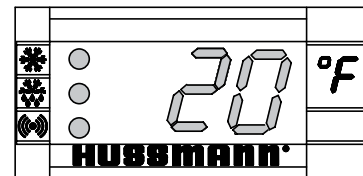

Display - at #1 Position
Model LBN

DUAL TEMPERATURE ADJUSTMENT

1. Rotate the adjustment knob counter clockwise for a warmer setpoint or clockwise for a colder setpoint.
2. While adjusting the temperature, the display shows the setpoint (cut out value). A few seconds after the temperature is set, the controller reverts to the sensed temperature in the merchandiser.
3. To verify merchandiser settings, turn the dial to warm and cold as shown above. Output readings should be within one degree of the temperatures shown above.

Typical Sensor to Control Configuration

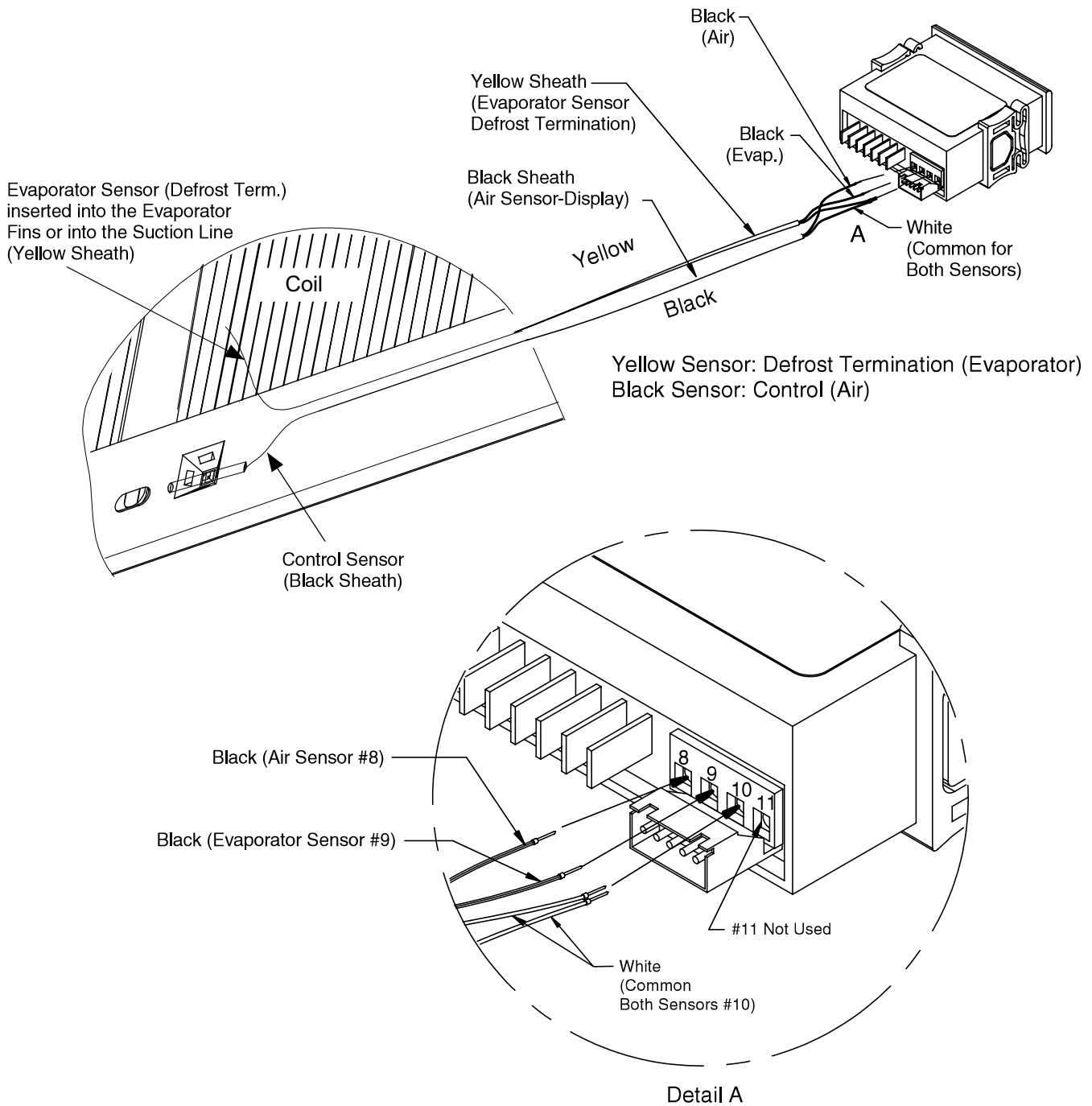

MAINTENANCE

CARE AND CLEANING

Long life and satisfactory performance of any equipment is dependent upon the care it receives. To ensure long life, proper sanitation and minimum maintenance costs, these merchandisers should be thoroughly cleaned, all debris removed and the interiors washed down, weekly.

Exterior Surfaces

The exterior surfaces must be cleaned with a mild detergent and warm water to protect and maintain their attractive finish. **NEVER USE ABRASIVE CLEANSERS OR SCOURING PADS.**

Interior Surfaces

The interior surfaces may be cleaned with most domestic detergents, ammonia based cleaners and sanitizing solutions with no harm to the surface. Self contained models empty into a limited capacity evaporation pan, which will overflow if excess water is used in cleaning.

Do NOT Use:

- Abrasive cleansers and scouring pads, as these will mar the finish.
- Coarse paper towels on coated glass.
- Ammonia-based cleaners on acrylic parts.
- Solvent, oil or acidic based cleaners on any interior surfaces.
- Do not use high pressure water hoses.



WARNING

Product will be degraded and may spoil if allowed to sit in a non-refrigerated area.

Do:

- Disconnect electrical power before cleaning.**
- Remove the product and all loose debris to avoid clogging the waste outlet.
- Store product in a refrigerated area such as a cooler. Remove only as much product as can be taken to the cooler in a timely manner.
- Thoroughly clean all surfaces with soap and hot water. **DO NOT USE STEAM OR HIGH WATER PRESSURE HOSES TO WASH THE INTERIOR. THESE WILL DESTROY THE MERCHANDISERS' SEALING CAUSING LEAKS AND POOR PERFORMANCE.**
- Lift hinged fan plenum for cleaning. Hook chain in rear panel to secure plenum during cleaning. **BE SURE TO REPOSITION THE FAN PLENUM AFTER CLEANING MERCHANDISER.**
- Take care to minimize direct contact between fan motors and cleaning or rinse water.
- Do NOT flood merchandiser with water. **NEVER INTRODUCE WATER FASTER THAN THE WASTE OUTLET CAN REMOVE IT.**

SELF CONTAINED MODELS EMPTY INTO AN EVAPORATION PAN THAT WILL OVERFLOW IF TOO MUCH WATER IS INTRODUCED DURING CLEANING.

(WATER FROM EVAPORATOR COIL ONLY)

- Allow merchandisers to dry before resuming operation.
- After cleaning is completed, turn on power to the merchandiser.



WARNING

Do NOT allow cleaning agent or cloth to contact food product.



WARNING

— LOCK OUT / TAG OUT —

To avoid serious injury or death from electrical shock, always disconnect the electrical power at the main disconnect when servicing or replacing any electrical component. This includes, but is not limited to, such items as doors, lights, fans, heaters, and thermostats.



CAUTION

DO NOT FLOOD!

Use only enough water necessary to clean surface. Water must not drip down the case!

Never use ammonia based cleansers, abrasive cleansers, or scouring pads.

CLEANING DISCHARGE AIR GRILLE

Discharge air air grilles should be cleaned every six months. Dirty air grilles will cause merchandisers to perform poorly. The air grilles may be cleaned with a vacuum cleaner. Soap and water may be used if all water is removed from the air grilles cells before replacing. Be careful not to damage the air grilles.

CLEANING SOLAR THERMOMETER

LBN models have solar thermometers. The thermometer is located at the top, front center of the merchandiser's cabinet interior.

To clean the thermometer:

1. Remove the two screws securing the thermometer to its mounting bracket. Remove the sensing element from the clip
2. Use non-abrasive cleaning materials and a mild detergent to clean thermometer.
3. Be sure to wipe the element clean of any residues.

CLEANING COILS

Condenser coils should be cleaned at least once per month. Additional cleaning may be needed depending on the operational environment.



TUBE or FIN COILS

Airflow blockage increases energy consumption and reduces the merchandiser's ability to maintain operating temperature.

To clean fin coils, use a vacuum cleaner with a wand attachment and a soft (non-metallic) brush to remove dirt and debris. Do not bend coil fins. Always wear gloves and protective eye wear when cleaning near sharp fins and dust particles.

The condenser is of bare-tube construction on the LBN-4, 6, 7 and 8 to reduce the amount of required maintenance required, and fin-and-tube construction on the LBN-10.

To ease in the cleaning of the bare-tube condenser, the top of the condenser shroud is removable. Slit the upper corners of the gasket on the front of the condenser. Remove the screws holding the shroud top into the shroud ends, and remove the top to gain full access to the condenser.

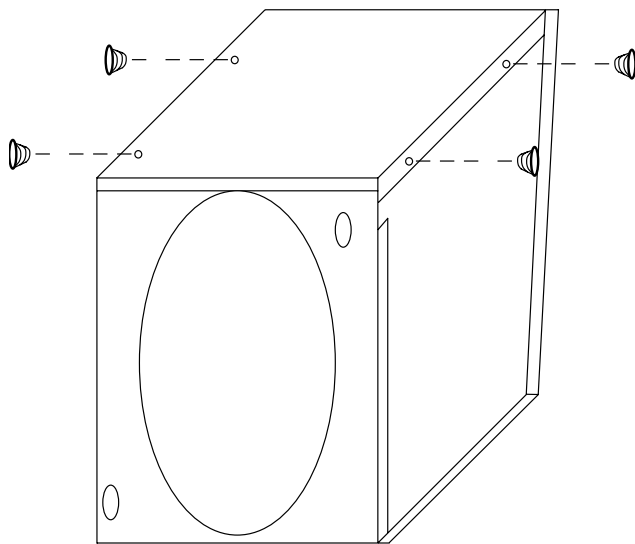

Remove Screws to Access Condenser

The glass lids are made of tempered, non-heat-ed glass. The lids slide up to open and can be locked open for product loading. The lids are not self-closing. The lids will close easily by hand and with the assistance of gravity. There is a nylon glide on the edge of the glass to assist in closing. The lid tracks must be cleaned periodically to allow the lids to close freely.

⚠ WARNING

SHUT FANS OFF DURING CLEANING PROCESS.

Manually defrost cabinet as usage dictates. The LBN series are gravity-cooled cabinets. The sidewalls have refrigeration tubing in them to cool the lower portion of the interior and there is an upper evaporator that drops cold air down onto the product. The upper coil is equipped with defrost heaters that defrost the coil. The side walls of the cabinet will build up frost and ice on them over time and do need to be manually defrosted as usage and build up demands.

CLEANING EVAPORATION PAN

The condensate water outlet for self contained models empties into a limited capacity evaporation pan.

Debris or dirt accumulation inside the condensate evaporation pan will reduce the pan’s evaporation capacity.

Remove accumulated debris from the evaporation pan. Water introduced during cleaning will cause the evaporation pan to overflow.

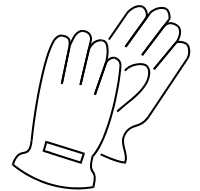

⚠ CAUTION

Always Wear gloves and protective eye wear when servicing. Turn off evaporation pan heater, and allow pan to cool.

CLEANING STAINLESS STEEL SURFACES

Use non-abrasive cleaning materials, and always polish with grain of the steel. Use warm water or add a mild detergent to the water and apply with a cloth. Always wipe rails dry after wetting.

Use alkaline chlorinated or non-chlorine containing cleaners such as window cleaners and mild detergents. Do not use cleaners containing salts as this may cause pitting and rusting of the stainless steel finish. Do not use bleach.

REMOVING SCRATCHES FROM BUMPER

Most scratches and dings can be removed using the following procedure.

1. Use steel wool to smooth out the surface area of the bumper.
2. Clean area.
3. Apply vinyl or car wax and polish surface for a smooth glossy finish.

**WARNING**

Do NOT use HOT water on Cold glass Surfaces. This can cause the glass to shatter and could result in personal injury. Allow glass fronts, to warm before applying hot water.



PRECAUTION
CLEANING PRECAUTIONS

When Cleaning:

- Do not use high pressure water hoses
- Do not introduce water faster than waste outlet can drain
- NEVER INTRODUCE WATER ON SELF CONTAINED UNIT WITH AN EVAPORATION PAN
- NEVER USE A CLEANING OR SANITIZING SOLUTION THAT HAS OIL BASE (these will dissolve the butyl sealants) or an AMMONIA BASE (this will corrode the copper components of the merchandiser)
- TO PRESERVE THE ATTRACTIVE FINISH:
- Use a water and a mild detergent for the exterior only
- Do NOT use a chlorinated cleaner on any surface
- Do NOT use abrasives or steel wool scouring pads (these will mar the finish)

SERVICE

DEFROST THERMOSTAT REPLACEMENT

The defrost thermostat is located on its mounting plate, at the right end of the evaporator coil attached to the air scoop. The air scoop is a right angle piece of metal running in front of the evaporator behind the nose screen. The thermostat is a bi-metal thermostat that is tied in series with the defrost time clock solenoid to end defrost when the temperature has been satisfied (85° F).

To Replace Defrost Thermostat:

1. If it is determined that the defrost thermostat needs to be replaced, disconnect electrical power to the merchandiser.
2. Remove the nose screen from in front of the evaporator.
3. Remove the stainless steel mirror reflector over the light fixture.
4. Refer to the wiring diagram for thermostat wiring terminations and disconnect.
5. Remove the air scoop located in front of the evaporator coil and the defrost thermostat mounting plate attached to it. Remove the thermostat, and disconnect wires.
6. Reverse this procedure to reinstall the new thermostat.

WARNING

— LOCK OUT / TAG OUT —

To avoid serious injury or death from electrical shock, always disconnect the electrical power at the main disconnect when servicing or replacing any electrical component. This includes, but is not limited to, such items as doors, lights, fans, heaters, and thermostats.

DEFROST HEATER REPLACEMENT

The cabinet is equipped with two defrost heaters, which are wired in parallel, except for the LBN-4, 6, 7 and 8, 220V, which are wired in series. Wiring them this way allows for lower wattage which increases the life of the heater. **The drain pan does not have to be removed to replace the heaters.**

The heaters are equipped with plug-in connections that plug into the underside of the light fixture. Disconnect electrical power supply.

Remove the stainless steel reflector. Remove the nose screen in front of the evaporator area.

The heaters are held up against the evaporator by spring clips.

Press heaters down and pull up on the front edge of the heater clips. The heaters can be pulled forward.

When replacing be sure the back pass of the rear defrost heater goes into the retaining clip at the back of the drain pan. This is necessary to prevent ice build up in the drain pan.

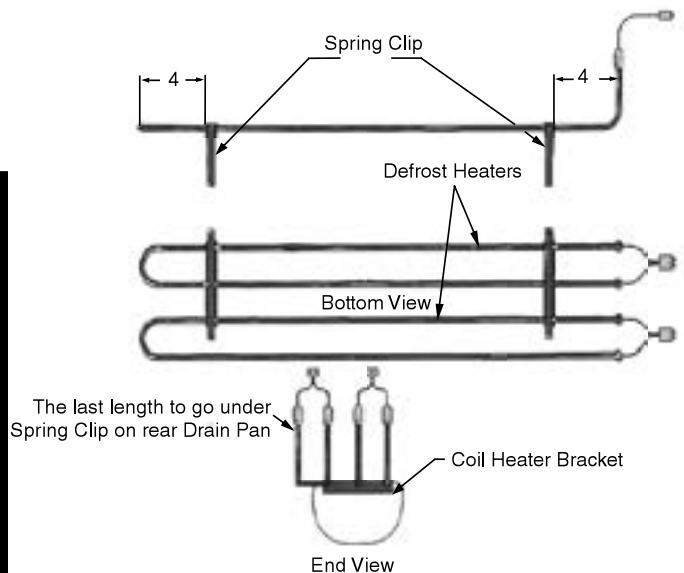

REPLACEMENTS OF ANTI-SWEAT HEATERS

There are anti-sweat heaters behind the stainless steel end panels, around the front glass, and behind the nose screen. These heaters are thermostatically controlled in case the cabinet malfunctions and thermostat senses above 101° F at which time the heaters will shut off.

REPLACEMENT OF END PANEL HEATERS

The end panel heaters are located behind the end panel stainless steel reflectors. They can be removed by removing the screws on the bottom edge of the panel and pulling down on the bottom edge. The heater is on adhesive foil on the backside of the panel.

End Panel Heater



WARNING

Product will be degraded and may spoil if allowed to sit in a non-refrigerated area.

REPLACING FLUORESCENT LAMPS AND BALLASTS

Cool, white fluorescent bulbs located on the underside of the stainless steel mirror reflector provide interior lighting for the merchandiser. The bulbs are sleeved to maintain proper heat around the bulb for maximum light intensity and to protect the bulb in case of breakage.

The tubes can be replaced without removing the doors. To replace, twist the bulb and slide the prongs clear of the lamp holder. When reinstalling this type of bulb, be sure the prongs on the bulb twist, and lock into place.

There is a convenient ON/OFF switch located at the right end of the case cabinet, behind the mirror reflector. This switch only controls the lights. The lights should always be left ON to prevent moisture from forming on the mirror reflector. This is especially important for high-humidity environments.

The light ballast is located in the light fixture. Remove the mirror reflector to access the ballast.

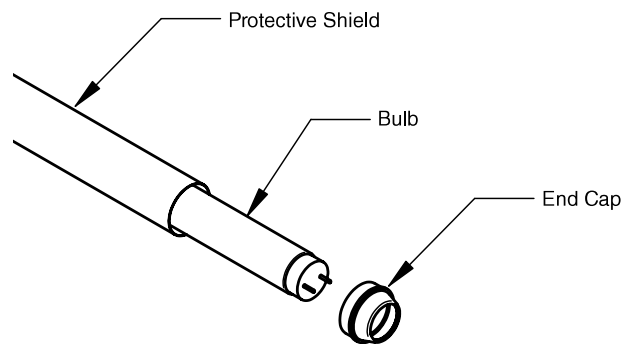

Remove Plastic Pins Attaching Display Lamp.

LED FIXTURE REPLACEMENT

Follow the same steps previously described for fluorescent lamps to remove LED fixtures. However, the protective shield does not need to be removed from the LED fixture. It is integrated into the fixture and is replaced along with the new LED fixture.

REPLACING LED POWER SUPPLIES

LED power supplies are located in the light fixture as well. Remove the mirror reflector to access the power supply connections.

FRONT GLASS HEATER REPLACEMENT

The front glass heater is built as part of the glass assembly. The purpose of the heater is to keep the aluminum trim surrounding the glass free of condensation. If the cabinet is located in a high humidity environment, the center of the glass may have a trace of condensation across it.

To replace the glass assembly:

1. Disconnect power to the cabinet. Remove the cabinet top by removing the screws that hold it into the back of the cabinet, and on each end.
2. Lift the top off the cabinet.
3. Remove the lids.
4. Remove the screws holding the backs of the lid tracks to the galvanized sub-top and the screws holding the center tracks to the aluminum rail on top of the front glass.
5. Remove the plastic arm trim breakers in the end aluminum trim pieces to expose the

screws in them. Remove screws and remove end trim.

6. Remove the trim from the top of the front glass.
7. Pull the front glass up and out exposing the wires at the right hand end of the glass and disconnect.
8. Replace the glass assembly.
9. Reverse procedure to reassemble.

NOSE HEATER REPLACEMENT

The nose heater is located behind the nose screen that is in front of the evaporator. Remove the nose screen replace heater.

ANTI-SWEAT HEATER LIMIT THERMOSTAT

The anti-sweat heater limit thermostat is a safety feature that will shut off the condensate heaters just discussed when the thermostat senses 101° F.

The thermostat is located on the defrost thermostat mounting bracket, which is on the air scoop behind the nose screen in front of the evaporator.

TROUBLESHOOTING GUIDE

PROBLEM	PROBABLE CAUSE	SOLUTION
Compressor runs continuously product too warm	<ol style="list-style-type: none"> 1. Short of refrigerant 2. Inefficient compressor 3. Dirty condenser 4. Evaporator oil logged 	<ol style="list-style-type: none"> 1. Leak check, change drier, evacuate, and recharge 2. Replace 3. Clean 4. Blow oil out of evaporator
High head pressure	<ol style="list-style-type: none"> 1. Cabinet location too warm 2. Restricted condenser air flow 3. Defective condenser fan motor 4. Air or non-condensable gases in system 	<ol style="list-style-type: none"> 1. Relocate cabinet 2. Clean condenser to remove air flow restriction 3. Replace 4. Leak check, change drier, evacuate and recharge
Warm storage temperature	<ol style="list-style-type: none"> 1. Temperature control not set properly 2. Short of refrigerant 3. Cabinet location too warm 4. Too much refrigerant 5. Low voltage, compressor cycling on overload 6. Condenser dirty 	<ol style="list-style-type: none"> 1. Reset control. 2. Leak check, replace drier evacuate and recharge 3. Relocate 4. Change drier evacuate, and recharge 5. Check power 6. Clean
Compressor runs continuously product too cold	<ol style="list-style-type: none"> 1. Defective control 2. Control feeler not in tube properly / sensor incorrectly located. 3. Short on refrigerant 	<ol style="list-style-type: none"> 1. Replace 2. Assure proper length in tube / install sensor at correct location 3. Leak check change drier, evacuate and recharge

PROBLEM	PROBABLE CAUSE	SOLUTION
Compressor runs continuously product too cold	<ol style="list-style-type: none"> 1. Defective control / Power relay 2. Control feeler not in tube properly 3. Short on refrigerant 	<ol style="list-style-type: none"> 1. Replace 2. Assure proper length in tube 3. Leak check change drier, evacuate and recharge
Compressor will not start no noise	<ol style="list-style-type: none"> 1. Blown fuse or breaker 2. Defective or broken wiring 3. Defective overload 4. Defective temperature control 5. Power disconnected 	<ol style="list-style-type: none"> 1. Replace fuse or reset breaker 2. Repair or replace 3. Replace 4. Replace 5. Check service cords or wiring connections
Compressor will not start cuts out on overload	<ol style="list-style-type: none"> 1. Low voltage 2. Defective compressor 3. Defective relay 4. Restriction or moisture 5. Inadequate air condenser 6. Defective condenser fan motor 7. CRO not set properly 	<ol style="list-style-type: none"> 1. Contact electrician 2. Replace 3. Replace 4. Leak check, replace drier, evacuate and recharge 5. Clean condenser 6. Replace 7. Reset to 10 psig.
Low suction pressure Low head pressure	<ol style="list-style-type: none"> 1. CPR not set properly 	<ol style="list-style-type: none"> 1. Reset to 10 psig.

PROBLEM	PROBABLE CAUSE	SOLUTION
Icing condition in drain pan under evaporator	<ol style="list-style-type: none"> 1. Low voltage 2. Cabinet not level 3. Defective defrost heater 4. Drain trap does not have water in it 	<ol style="list-style-type: none"> 1. Check voltage at compressor 2. Check front to rear leveling 3. Replace 4. Pour water down drain
Low suction pressure Low head pressure	<ol style="list-style-type: none"> 1. CPR not set properly 2. Defective CPR 3. Capillary tube blocked due to water or dirt 4. Short of refrigerant 	<ol style="list-style-type: none"> 1. Replace to 10 psig. 2. Replace 3. Change drier, evacuate and recharge 4. Leak check change drier, evacuate and recharge
Pressures normal cabinet warm	<ol style="list-style-type: none"> 1. Top coil blocked with frost 2. Evaporator oil logged 	<ol style="list-style-type: none"> 1. Check defrost system 2. Blow oil out of evaporator

LIGHT PROBLEM / SOLUTION

PROBLEM	SOLUTION
Lights won't start	<ol style="list-style-type: none"> 1. Check light switch 2. Check continuity to ballast 3. Check to see if bulbs are inserted properly in sockets 4. Check voltage
Ballast hums	<ol style="list-style-type: none"> 1. Check voltage 2. Replace ballast

Lights Flicker	<p style="text-align: center;">SOLUTION</p> <ol style="list-style-type: none"> 1. Allow lamps to warm up (fluorescent) 2. Check lamp sleeves for cracks (fluorescent) 3. Check sockets for moisture and proper contact (all) 4. Bulb replacement may be necessary (all) 5. Check voltage (all) 6. New bulbs tend to flicker until used (fluorescent)
----------------	---

LBN ACCESSORIES AND OPTIONS

The following is a description of the various accessories available for the LBN:

Bag Rack — A big rack can be provided to store various size checkout bags. The rack attaches to the back of the cabinet.

Caster Kit — If the cabinet needs to be moved quite often or for additional health code regulations, the caster kit raises the cabinet approximately 4 1/2 inches. The wheel of the caster is 3 inches.

Counter Top — The metal counter top is standard, and a 16 in. and 20 in. wooden counter top can be provided. The 16 in. wooden counter top mounts flush with the back of the cabinet.

Dial Thermometer — The cabinet can be provided with a two-inch dial thermometer, rather than the standard pencil type thermometer. THIS MUST BE FACTORY INSTALLED. It is located in the left end of the upper stainless steel reflector above the light fixture.

Electronic Controls — includes controller (to set temperature), Led display and 2 sensors (Air & defrost)

Electromechanical Controls — includes thermostat and defrost timer.

LED Lights — similar lighting distribution when compared to fluorescent and reduced energy consumption.

Lid Lock Kit — For product security, a lid lock kit can be provided. Each kit secures two lids.

Novelty Basket — For the storage and display of novelty items, the novelty basket is ideal. The basket is epoxy-coated white, and it is 10 in. x 12 in. x 6 1/2 inches high. Basket dividers are also available.

Product Shelf Kit — The interior of the LBN series a raised step over the condensing unit compartment. The product shelf kit is a false bottom of the cabinet level with the raised step.

Stainless Steel Top — Like the counter tops, the stainless steel top replaces the standard metal countertop for those who need a highly durable working surface.

Superstructure with Lighted Canopy — The cabinet can be provided with a superstructure, which has two shelves, and a lighted canopy that attaches to the back of the cabinet. The superstructure allows for the storage of dry goods without the need for additional floor space.

Superstructure without Lighted Canopy — The superstructure can be ordered without the lighted canopy. Superstructure is still supplied with two shelves.

COMPRESSOR REPLACEMENT PROCEDURE

Replacement compressors will not be shipped from the Hussmann factory. They may be obtained from your nearest Copeland wholesaler.

Your wholesaler will replace, free of charge, any compressor found to be defective within 12 months of installation, not to exceed 20 months from the date of manufacture as determined by the compressor serial number on the compressor serial plate.

For any defective compressor beyond the 12 month or 20 month time period, a salvage value credit will be given to partially offset the invoice for replacement.

After March 16, 1991 when all cases have the five-year warranty as standard, the following procedure applies:

FORWARD TO YOUR NEAREST HUSSMANN
DISTRIBUTOR:

1. The cabinet model and serial number.
2. A copy of the wholesaler's invoice, along with a copy of the salvage value credit.

INTERNAL LEAK WARRANTY POLICY

The LBN series are warranted from the date of factory shipment for five years for an internal leak. An internal leak not only includes the cold-wall tubing but the upper evaporator as well on these models.

If it is felt that there is an internal leak in the cabinet, care should be taken to actually determine that there is a leak.

To do this properly, the cabinet's evaporator section must be isolated from the condenser section.

Unbrazed the tubes going into the back of the cabinet at the end of the heat exchanger.

Pinch or cap the larger tube and braze shut.

Add a schrader valve to the smaller tube.

Attach the high side gauge of a compound gauge to the valve and pressurize the cabinet with nitrogen or otherwise suitable gas.

There should be at least 300 psig on the system.

Mark the pressure on the gauge and leave it, returning 24 hours later.

Note the pressure. If it has fallen more than 150-200 psig then the system may have an internal leak.

If it only drops a small amount this does not mean that you have an internal leak, but that the gas in the cabinet is cooler and has reduced its pressure because of this.

If the cabinet has an internal leak contact the nearest Hussmann distributor or the factory to receive authorization to return the cabinet to the factory.

**NO MERCHANDISER WILL BE ACCEPTED AT THE
FACTORY WITHOUT A LETTER OF AUTHORIZATION
FOR RETURN.**

DOE 2012
Energy Efficiency
Compliant

Husmann refrigerated merchandisers configured for sale for use in the United States meet or surpass the requirements of the DOE 2012 energy efficiency standards.

**Standard
Parts List**

Models		LBN-4	LBN-6	LBN-7	LBN-8	LBN-10
Standard Parts						
Description	Part Number					
Defrost Time clock 48hr (E357-00B)	03S268	X	X	X	X	
Defrost Time clock 24hr (8145-20B)	03S072					X
Temperature Control	04S035	X	X	X	X	X
Power Switch	03S286	X	X	X	X	X
Defrost Heater Limit Thermostat	03S575	X	X	X	X	X
Defrost Heater Thermostat	03S118	X	X	X	X	X
Thermometer	1700559	X	X	X	X	X
White- Wire Front Product Stop (1/2)	22S2711	X			X	
White- Wire Front Product Stop (2)	22S2712					X
White- Wire Front Product Stop (2)	22S2713		X			
White- Wire Front Product Stop	22S2714			X		
Complete Lid Assembly (2/3/4)	657581	X	X		X	
Complete Lid Assembly (4)	657582					X
Complete Lid Assembly (3)	657583			X		
Lid Glass	29S387	X	X		X	
Lid Glass	29S388			X		
Lid Glass	29S389					X
Lid Glass End Cap (black) 2 per lid	18S1241	X	X	X	X	X
Front Lid Rail/ Handle	30S6501	X	X		X	
Front Lid Rail/ Handle	30S6502					X
Front Lid Rail/ Handle	30S6503			X		
Rear Lid rail	29S5131	X	X		X	
Rear Lid rail	29S5132					X
Rear Lid rail	29S5133			X		
Front Lid Rail Gasket	18S114	X	X		X	
Front Lid Rail Gasket	18S138					X
Front Lid Rail Gasket	76213			X		
Copper Drain Trap	65783	X	X	X	X	X
Lid Catch (Nylon) Located under countertop	29S655	X	X	X	X	X
Light Fluorescent F30 T8 CW	06S029	X		X	X	
Light Fluorescent F40/D41 CW	06S010		X		X	X
Light Sheild	06S0743	X		X	X	
Light Sheild	06S0742		X		X	X
Ballast	06S016	X	X			
Ballast	06S187			X	X	
Ballast	06S123					X
Lamp Holder	06S185	X	X	X	X	X
Starter Socket	06S024	X	X			
Starter (FS4)	06S019	X	X			
Light Switch	03S176	X	X	X	X	X
Wiper Gasket (located over lids) 2/3/4	18S128	X	X		X	
Wiper Gasket (located over lids) 3/4	18S140			X		X
Aluminum Ticket Molding Extr.	30S7281	X				
Aluminum Ticket Molding Extr.	30S7283		X			
Aluminum Ticket Molding Extr.	30S7284			X		
Aluminum Ticket Molding Extr.	30S7285				X	
Aluminum Ticket Molding Extr.	30S7286					X
Front Bumper (Grey)	18S2921	X	X	X	X	X
Front Bumper End Cap (Grey)	18S3091	X	X	X	X	X
End Arm Trim Bumper (Grey) 27" Lg.	18S1201G	X	X	X	X	X

**Parts List
Continued**

Models		LBN-4	LBN-6	LBN-7	LBN-8	LBN-10
Refrigeration						
Description	Part Number					
Compressor (Aspera NT2192GKV)	2000588	X				
Compressor (Copeland KAGB-005E-IAA)	02S443		X			
Compressor (Copeland KAAB-007E-CAA)	02S444			X	X	
Compressor (Copeland KALB-010E-CAV)	02S445					X
Condenser Assy (3 Pass) Painted	658822	X	X			X
Condenser Assy (4 Pass) Painted	65885			X	X	
Condenser (Fin & Tube)	25S040					X
Condenser Fan Motor	21S072	X	X	X	X	
Condenser Fan Motor	21S071					X
Condenser Fan Blade	21S017	X	X	X	X	
Condenser Fan Blade	21S015					X
Condenser Fan Motor Bracket	21S007	X	X	X	X	X
Drier C-032S-T	17S332	X				
Drier C-052-S	17S362		X	X	X	X
CPR (Sporlan CRO-4) Comes with Ht X'chr	17S114	X	X	X	X	X
Pullout Coil/Heat exchanger	76217	X				
Pullout Coil/Heat exchanger	659560		X			
Pullout Coil/Heat exchanger	659591			X	X	
Pullout Coil/Heat exchanger	76136					X

Models		LBN-4	LBN-6	LBN-7	LBN-8	LBN-10
Heaters						
Description	Part Number					
Defrost Heater (2)	19S466	X				
Defrost Heater (2)	19S468		X			
Defrost Heater (2)	19S469			X		
Defrost Heater (2)	19S470				X	
Defrost Heater (2)	19S626					X
Anit-Sweat Nose Heater	19S232	X				
Anit-Sweat Nose Heater	19S233		X			
Anit-Sweat Nose Heater	19S248			X		
Anit-Sweat Nose Heater	19S234				X	
Anit-Sweat Nose Heater	19S563					X
Anit-Sweat End Panel Heater LH	19S2352	X	X	X	X	X
Anit-Sweat End Panel Heater RH	19S2351	X	X	X	X	X
Front Glass w/ Heater	0523864	X				
Front Glass w/ Heater	0523865		X			
Front Glass w/ Heater	0523866			X		
Front Glass w/ Heater	0523867				X	
Front Glass w/ Heater	0523868					X

**Parts List
Continued**

Models		LBN-4	LBN-6	LBN-7	LBN-8	LBN-10
Sheet Metal Replacement Parts Painted						
Description	Part Number					
Front Access Panel	76018	X	X	X	X	X
Rear compressor compartment cover	65379	X	X	X	X	
Rear compressor compartment cover	1H16528001					X
Rear Drain Cover	65531	X	X	X	X	X
Front compressor hold down assy	1H10458001	X	X	X	X	X
Metal Countertop	760081	X				
Metal Countertop	760083		X			
Metal Countertop	760084			X		
Metal Countertop	760085				X	
Metal Countertop	760086					X
Lower Front Panel (below bumper)	760101	X				
Lower Front Panel (below bumper)	760103		X			
Lower Front Panel (below bumper)	760104			X		
Lower Front Panel (below bumper)	760105				X	
Lower Front Panel (below bumper)	760106					X
Evaporator Drain Pan Assy	763171	X				
Evaporator Drain Pan Assy	763173		X			
Evaporator Drain Pan Assy	763174			X		
Evaporator Drain Pan Assy	763175				X	
Evaporator Drain Pan Assy	763176					X
Aluminum Trim Arm Assy LH	30S8671	X	X	X	X	X
Aluminum Trim Arm Assy RH	30S8672	X	X	X	X	X
Water Pan	524794	X	X	X	X	X
*All these part numbers below are painted assemblies (standard color is White)						

**Parts List
Continued**

Models		LBN-4	LBN-6	LBN-7	LBN-8	LBN-10
Optional LED Interior lights						
Description	Part Number					
LED Light Tube (E1N5K-4100K0C3-S3)	0515964	X		X	X	
LED Light Tube (E1N5K-4100K0C3-S4)	0515965		X		X	X
LED Power Supply (40W)	0515168	X	X	X	X	
LED Power Supply (100W)	0518898					X
LED light Clip	0518906	X	X	X	X	X

Models		LBN-4	LBN-6	LBN-7	LBN-8	LBN-10
Safenet III Parts						
Description	Part Number					
Safenet III Controller Assembly	0524132	X	X	X	X	
Safenet III Controller Assembly Dual Temp	0524134	X	X	X	X	
Display	1H5905201	X	X	X	X	
Defrost Sensor Yellow 4000MM	0510532	X	X	X	X	
Air Sensor Black 4000MM	0510533	X	X	X	X	
Display Interface Cable	0509783	X	X	X	X	
Control Harness	0513058	X	X	X	X	
Compressor & Defrost Relay (120V)	0459304	X	X	X	X	

**LBN
Plan View**

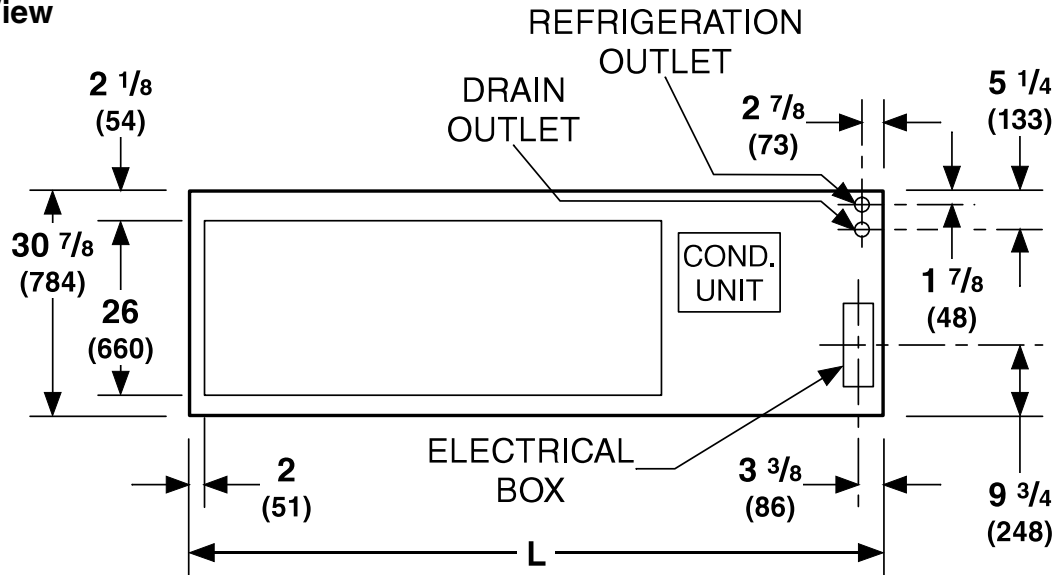

LBN-8 Shown

MODEL	L
LBN-4	48 1/2"
LBN-6	72"
LBN-7	84 1/4"
LBN-8	95 5/8"
LBN-10	118 7/8"

REFRIGERATION DATA

DEFROST DATA

**LBN-4, LBN-6, LBN-7
LBN-8, LBN-10**

Frequency (hr)	
LBN-4, 6, 7, 8	48
LBN-10	24

Thermostat

Setting CI/CO (°F)

Electromechanical 2:00 to 3:00 positions
-4° F / -12° F
Safe-NET III Position: #1 5° F / -5° F
#7 -18° F / -28° F

OFFTIME

Failsafe (minutes)
All models 40

Compressor (hp)

LBN-4 / LBN-6 1/2 hp
LBN-7 3/4 hp
LBN-8 / LBN-10 1 hp

Defrost Termination:

Temperature Terminated

Condensing Unit Capacity

LBN-4 / LBN-6 3330
LBN-7 3600
LBN-8 / LBN-10 5400
at -25° F evaporator and 110° F condenser
temperature (Btu/hr at standard ASHRAE
LBP rating conditions)

Refrigerant Charge		
LBN 4	31 oz.	0.878 kg
LBN 6	30 oz.	0.856 kg
LBN 7	36 oz.	1.026 kg
LBN 8	37 oz.	1.047 kg
LBN 10	35 oz.	1.000 kg

Note: This data is based on store temperature and humidity that does not exceed 75°F and 55% R.H. unless otherwise stated. Schedule defrost at night while lights are off.

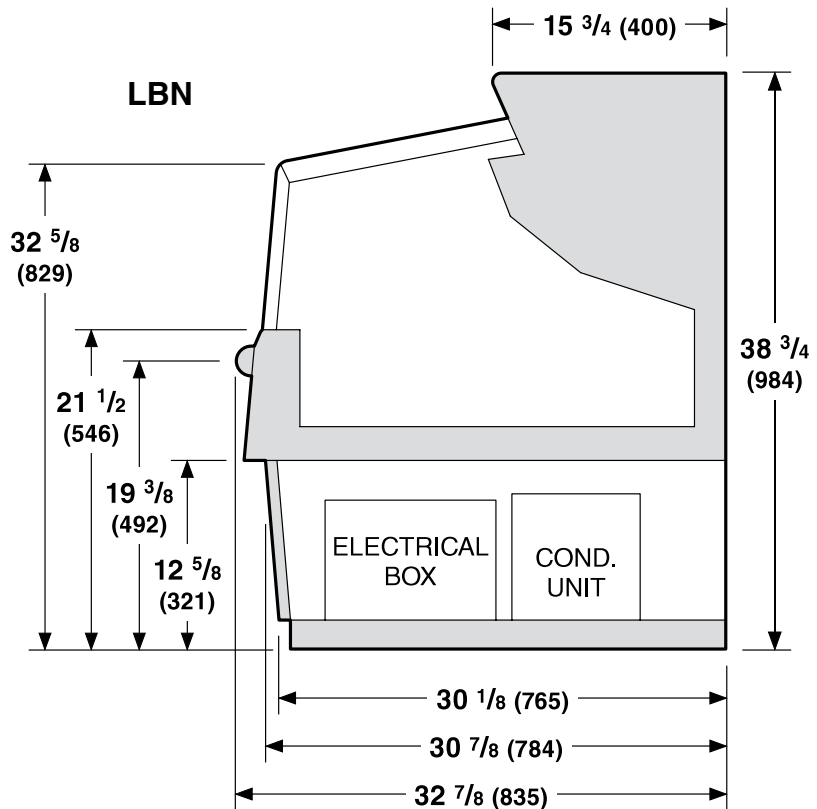

Dimensions shown as inches and (mm).

A-7 APPENDIX A — TECHNICAL DATA

Electrical Data

Note: These are rated values for individual components and should not be added together to determine total merchandiser electrical load.

Condensing Unit (115V, 1Ph, 60Hz) Standard

	LBN-4	LBN-6	LBN-7	LBN-8	LBN-10
Compressor LRA	56	45	59.8	59.8	40
Compressor RLA	10.5	10.2	12	12	7.7

Product Data

LBN-4 ARI Total Display Area ¹ (Sq Ft/Case)	360.76 ft ² /case (12.74 m ² /case)
LBN-6 ARI Total Display Area ¹ (Sq Ft/Case)	623.82 ft ² /case (22.03 m ² /case)
LBN-7 ARI Total Display Area ¹ (Sq Ft/Case)	757.48 ft ² /case (26.75 m ² /case)
LBN-8 ARI Total Display Area ¹ (Sq Ft/Case)	887.17 ft ² /case (31.33 m ² /case)
LBN-10 ARI Total Display Area ¹ (Sq Ft/Case)	1146.27 ft ² /case (40.48 m ² /case)

¹ Computed using ARI 1200 standard methodology:
Total Display Area, ft² [m²] / Unit of Length, ft [m]

Model Number	Nominal HP	Refrigerant Type	Electrical					Approx Ship Wt. (lb)
			Volts	Run Amps	NEMA Plug	fuse Amps	Hz/Ph	
LBN-4	1/2	R-404A	115	10.2	5-15P	15	60/1	515
LBN-6	1/2	R-404A	115	10.2	5-15P	15	60/1	663
LBN-7	3/4	R-404A	115	11.5	5-15P	15***	60/1	745
LBN-8	3/4	R-404A	115	12.0	5-15P	15***	60/1	815
LBN-10**	1	R-404A	115 208-230	2.7 9.0	Hard Wired	15	60/1	967

*field hard wired **LBN-10 has rear air discharge ***15 Amp time delay breaker or fuse required

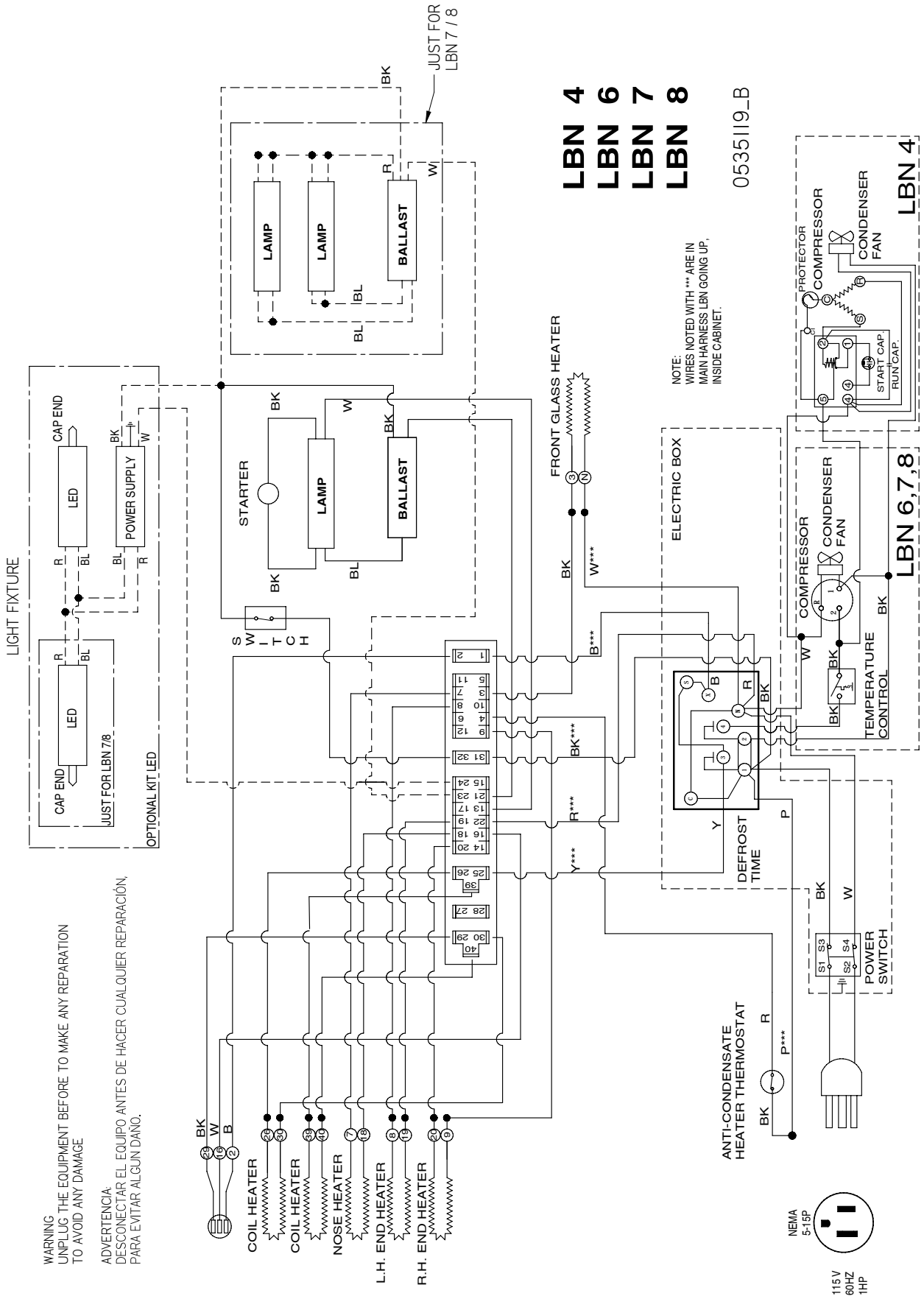

WARNING
UNPLUG THE EQUIPMENT BEFORE TO MAKE ANY REPAIRATION
TO AVOID ANY DAMAGE

ADVERTENCIA:
DESCONECTAR EL EQUIPO ANTES DE HACER CUALQUIER REPARACIÓN.
PARA EVITAR ALGUN DAÑO.

LBN 4
LBN 6
LBN 7
LBN 8

0535119_B

NOTE:
WIRES NOTED WITH *** ARE IN
MAIN HARNESS LBN GOING UP,
INSIDE CABINET.

WARNING

All components must have mechanical ground, and the merchandiser must be grounded.

R = Red Y = Yellow G = Green BL = Blue BK = Black W = White B = Brown O = Orange GR = Grey

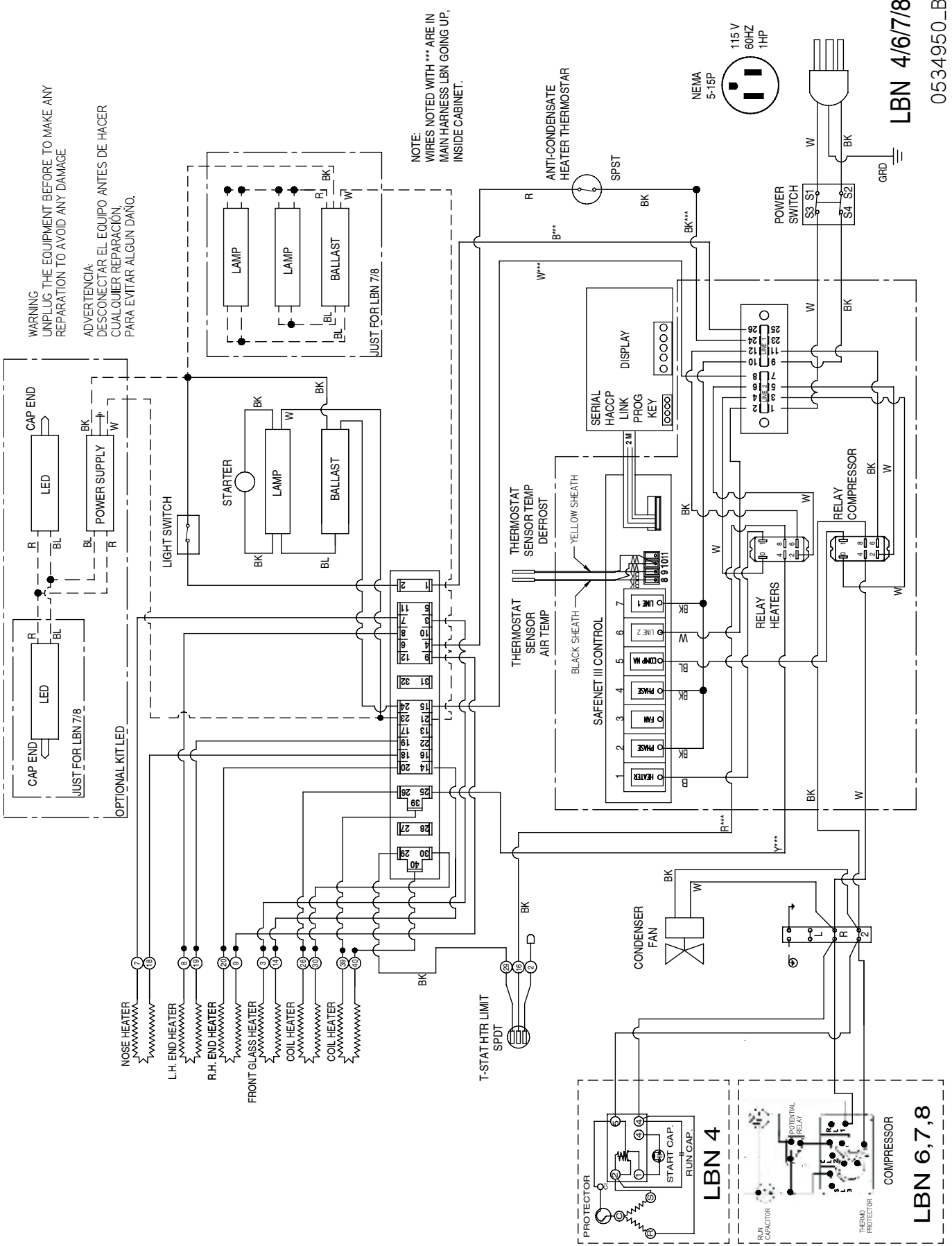

WARNING
UNPLUG THE EQUIPMENT BEFORE TO MAKE ANY REPAIRATION TO AVOID ANY DAMAGE

ADVERTENCIA:
DESCONECTAR EL EQUIPO ANTES DE HACER CUALQUIER REPARACIÓN, PARA EVITAR ALGUN DAÑO.

NOTE:
WIRES NOTED WITH *** ARE IN MAIN HARNESS LBN GOING UP, INSIDE CABINET.

LBN 4/6/7/8
0534950_B

WARNING
All components must have mechanical ground, and the merchandiser must be grounded.

R = Red Y = Yellow G = Green BL = Blue BK = Black W = White B = Brown O = Orange GR = Grey

WARNING
UNPLUG THE EQUIPMENT BEFORE TO MAKE ANY REPAIRATION TO AVOID ANY DAMAGE

ADVERTENCIA:
DESCONECTAR EL EQUIPO ANTES DE HACER CUALQUIER REPARACION.
PARA EVITAR ALGUN DAÑO.

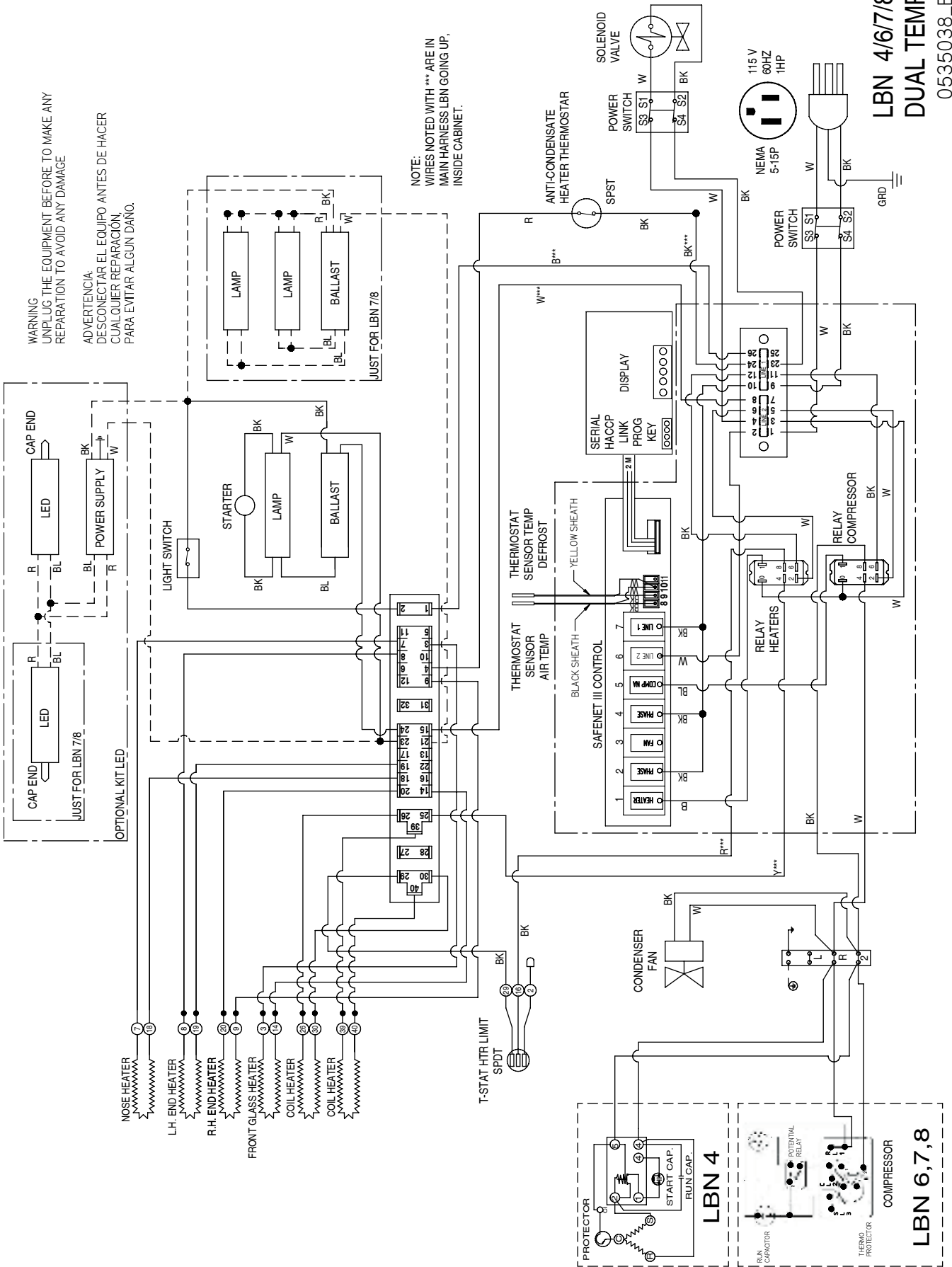

NOTE:
WIRES NOTED WITH *** ARE IN MAIN HARNESS LBN GOING UP, INSIDE CABINET.

LBN 4/6/7/8
DUAL TEMP
0535038_B

WARNING
All components must have mechanical ground, and the merchandiser must be grounded.

R = Red Y = Yellow G = Green BL = Blue BK = Black W = White O = Orange GR = Grey

WARNING
UNPLUG THE EQUIPMENT BEFORE TO MAKE ANY REPARATION
TO AVOID ANY DAMAGE

ADVERTENCIA:
DESCONECTAR EL EQUIPO ANTES DE HACER CUALQUIER REPARACIÓN,
PARA EVITAR ALGUN DAÑO.

DEFROST THERMOSTAT

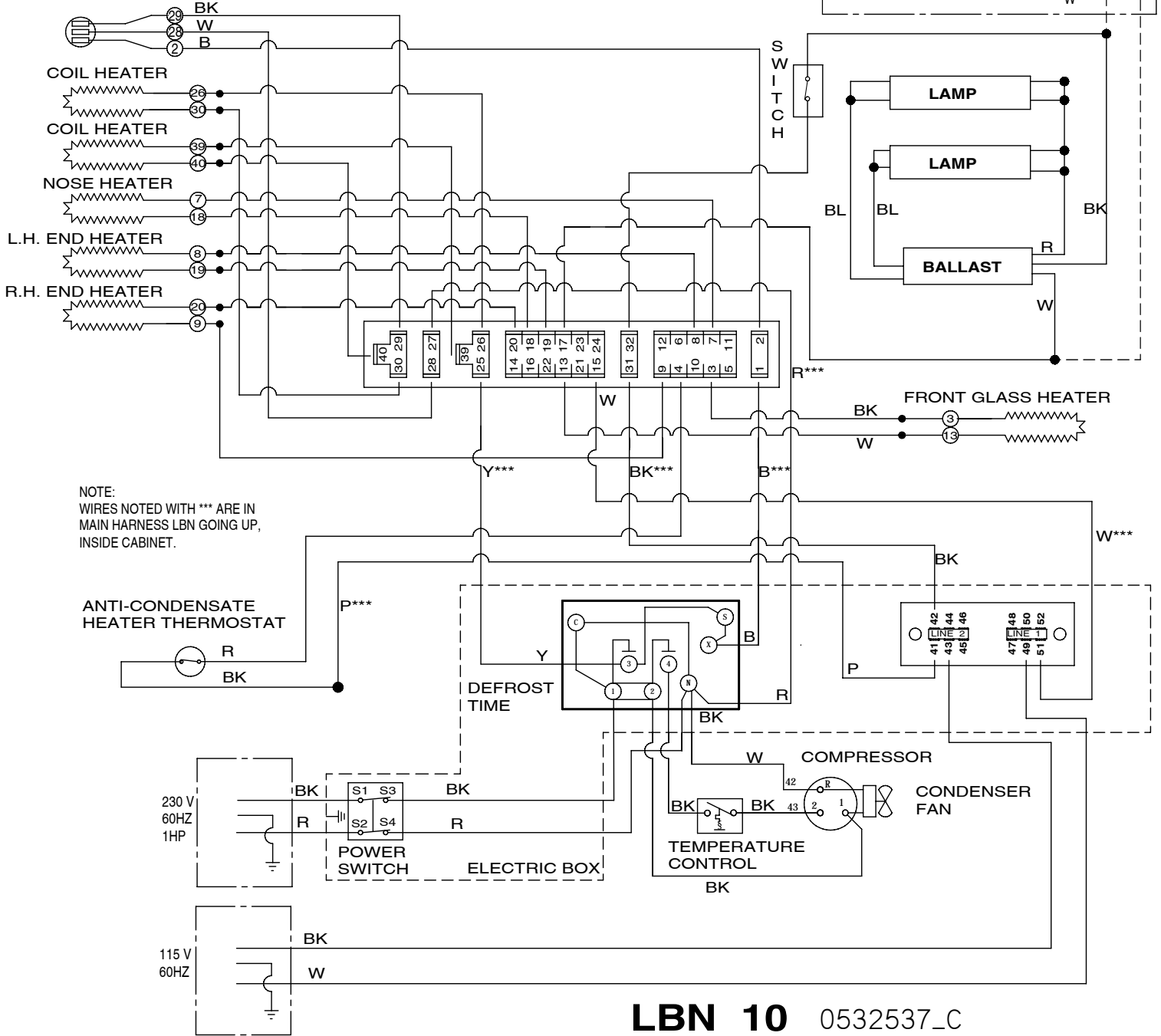

NOTE:
WIRES NOTED WITH *** ARE IN
MAIN HARNESS LBN GOING UP,
INSIDE CABINET.

LBN 10 0532537_C

WARNING

All components must have mechanical ground, and the merchandiser must be grounded.

R = Red Y = Yellow G = Green BL = Blue BK = Black W = White B = Brown O = Orange GR = Grey



HUSSmann[®]

**To obtain warranty information
or other support, contact your
Hussmann representative.
Please include the model and
serial number of the product.**

Hussmann Corporation, Corporate Headquarters: Bridgeton, Missouri, U.S.A. 63044-2483 01 October 2012