

HUSSMANN®

RLN-W

NARROW REACH-IN MERCHANDISER

EVOLVE™

R-290

RLN-W

SELF-CONTAINED MERCHANDISER WITH INNOVATOR DOORS

microDS™



ADVANTAGES

- Ideal for any low temperature or frozen food products
- Environmentally-friendly R-290 natural refrigerant that has zero ozone depletion potential (ODP) and 3 Global Warming Potential (GWP)
- High pack-out in limited footprint allowing more product in the same space
- UL Listed, NSF Type II compliant, and DOE 2017 certified



KEY FEATURES

- The display area per door is identical to the capacity of the standard depth RL
- Available with Hussmann Innovator and Innovator III doors
- Merchandiser rejects heat through a continuous flow store level water-loop system that operates between 50° and 115° F inlet temperature
- 18, 20, and 22 inch shelves available for flat merchandising
- EcoShine II LED customized for optimal product lighting and reduced maintenance costs
- Detachable fan plenums for easy-to-clean case bottom
- CoreLink™ controller enabled remote performance monitoring available



1.800.592.2060



www.hussmann.com

RLN-W Narrow Self-Contained Reach-In Merchandiser



SERVICEABILITY

- Detachable fan plenums for easy-to-clean case bottom
- Remote performance monitoring available through CoreLink™ controller

SUSTAINABILITY

- EcoShine II LED customized for optimal product lighting and reduced maintenance costs
- Minimal environmental footprint with CO₂ ZERO Ozone Depletion and Global Warming Potential of 3

SPECIFICATIONS

Models	RLN2W, RLN3W, RLN4W, and RLN5W
Adjustable Leveling Legs	no
Casters	no
Color Exterior / Interior	black, grey, or white
Exterior Sign Panel	none
Insulation	polyurethane foam (CFC free)
LED Lighting	multiton
Number of Display Levels	6
Power Connection	NEMA L21-20P (2,3,4-Dr) or L21-30P (5-Dr)
	<div style="display: flex; justify-content: space-around;"> <div style="text-align: center;"> <p>L21-20P</p>  </div> <div style="text-align: center;"> <p>L21-30P</p>  </div> </div>
Power Supply	208 VAC / 3-phase / 60 Hz
Refrigerant	R-290 (propane)

AVAILABLE OPTIONS

- Lift-out bottom rack
- Heavy-duty front panels and deck pans
- Additional display shelves available
- Bumpers (front and ends)
- Price tag molding
- Product stops
- Contour fascia
- Heavy-duty shelves

NOTE: These merchandisers are designed for use in stores when temperature and humidity do not exceed 75° F (23.9° C) and 55% R.H.

We reserve the right to change or revise specifications and product design in connection with any feature of our products. Such changes do not entitle the buyer to corresponding changes, improvements, additions, or replacements for equipment previously sold or shipped. For additional resources, contact your representative or visit www.husmann.com.

TECHNICAL INFORMATION



Scan QR code with your mobile device to access additional information at www.husmann.com

Available with 2, 3, 4, or 5 doors per case.

DIMENSIONS

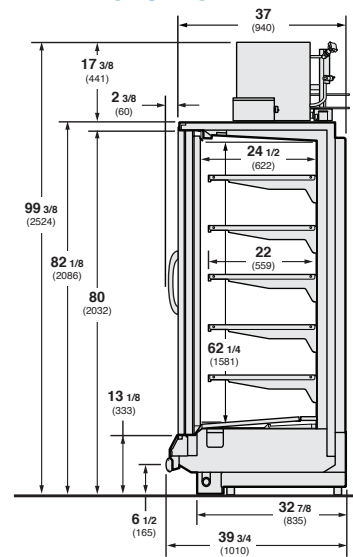

Note
Dimension are in
Inches (millimeters)

Gross Refrigerated Volume* - **22.8 ft³ / ft**
(0.65 m³ / m)

*per ANSI/AHRI 1200-2013
appendix C. Volume Calculation

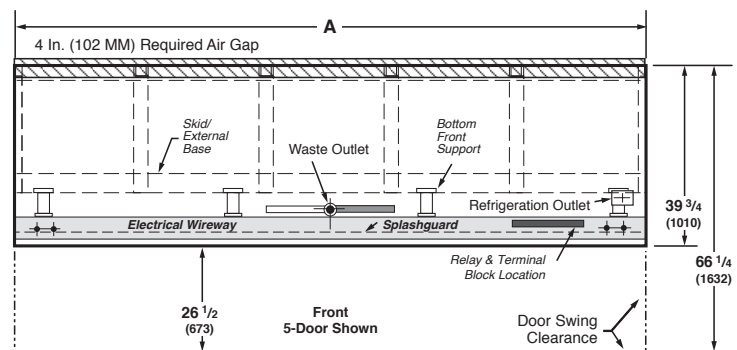

Dimensions	2-Door	3-Door	4-Door	5-Door
A	62 (1,575)	92 1/2 (2,350)	122 7/8 (3,121)	153 3/8 (3,896)

Note: Contact your sales representative for information on possible availability of additional case lengths.

HUSSMANN®

Husmann Corporation
12999 St. Charles Rock Rd.
Bridgeton, MO 63044-2483
Ph: 1.800.592.2060

www.husmann.com