

**HUSSMANN®**

---

Specialty



---

*Q-Series Family*

**Q3-BS**

Service Merchandiser with Straight Glass -  
Refrigerated or Dry Multi-Deck Bakery

---

[www.hussmann.com](http://www.hussmann.com)

# Hussmann Q-Series Service Merchandiser with Straight Glass - Refrigerated or Dry Multi-Deck Bakery

## Q3-BS



### Reduced Light Reflection and Distortion with Optional Hi-Def Glass

- Less than 2% reflectance - interior and exterior visible light. <sup>a</sup>
- Transmits 90% + visible light. <sup>a</sup>
- Blocks 99% UV transmittance. <sup>a</sup>
- Provides a unique look - flat glass on a curved case.

### LED Lighting

- 50% energy savings over T-8.
- 5-10 year lamp life.
- Excellent product illumination.
- Perfect for dimming or On/Off operation.



### Merchandising Visibility

Optional curved non-glare glass and built-in air sweep assures the product looks great.



### Merchandising Flair

Stylish clean lines combined with sleek design elements create enhanced product visibility. Granite or solid surface design allows for an amazing merchandising display unlike other service cases.

### Quality Fit and Finish

Designed for ease of installation... it has a simplified glass adjustment with a special alignment design that assures fit - does not require unsightly joint trim.



### Ergonomic Design

Large rear door opening and steep angle allow for ease of access to product.



## Q3-BS-R (Remote) and Q3-BS-D (Dry)

Lengths: 4', 5', 6', 8', 10', and 12'

Wedges: 22° inside/outside wedges, 45° inside/outside wedges

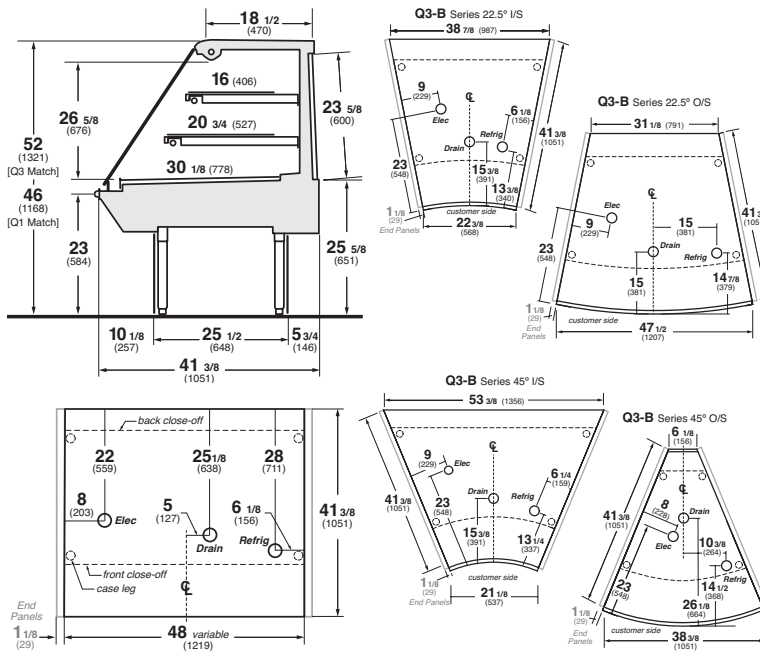

## Features.

- Tempered, non-glare, lift-up straight front clear glass
- Large clear glass sliding rear doors
- Silver anodized glass hardware
- Black thermoplastic front ledge
- Clear glass top
- Stainless steel interior
- Snap-on stainless steel lower rear panel
- Snap-on painted front panel
- Black vinyl cart bumper
- Double row LED canopy lights †
- Energy efficient fans (refrigerated)
- Solar digital thermometer (refrigerated)
- Front glass heated air sweep (refrigerated)
- Thermostat and suction stop installed
- Please reference color chart for choice of standard Hussmann paint and finish options ([www.hussmann.com](http://www.hussmann.com))

## Options.

- LED lighted shelves 16" and 20" (glass, stainless steel, or wire) †
- LED ledge lights †
- Clear glass top †
- Mirrored rear doors
- Thermoplastic wrapping boards with adjustable riser
- View or solid ends
- Mirror bright interior end panels
- Stainless steel pedestals
- Mirrored rear sliding doors
- Top mounted scale stand extensions with dedicated scale outlet and Cat 5 scale connections
- 15 amp GFCI duplex outlet
- Liquid line shut-off hand valve
- Custom lengths and options\*
- Special interior and exterior finishes\* (consult your Hussmann sales representative)

## Additional Information.

- Matching companion case lines: Q-Series Family
- Q-HS, Q-MS, Q1-DS, Q1-SS, Q3-DS, Q3-SP, Q3-SS, Q4-SS

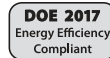

Hussmann refrigerated merchandisers configured for sale for use in the United States meet or surpass the requirements of the DOE 2017 energy efficiency standards.

\* Some optional features may need to be certified by UL, NSF, and/or other 3rd party certification agencies. Contact Hussmann for verification or questions for availability.

† Only lighting configurations that are compliant with the U.S. Dept. of Energy (DOE) 2017 regulation are available for sale for use in the U.S.A.

<sup>a</sup> Pilkington OptiView™ product literature.

NOTE: These merchandisers are designed for use in stores when temperature and humidity do not exceed 75°F and 55% R.H. We reserve the right to change or revise specifications and product design in connection with any feature of our products. Such changes do not entitle the buyer to corresponding changes, improvements, additions, or replacements for equipment previously sold or shipped.

For additional resources, contact your representative or visit [www.hussmann.com](http://www.hussmann.com)



### Note.

Use Hussmann's technical data sheets to get precise dimensions for all store layout purposes.

Intertek Intertek

## Hussmann Specialty

13770 Ramona Avenue  
Chino, California 91710-5423  
Ph: 800.395.9229

[www.hussmann.com](http://www.hussmann.com)

**HUSSMANN**