



PWW-E

PWW-E, PWWEE

Excel Wide Island Produce Merchandiser
for Bulk Produce Applications

Hussmann Excel Wide Island Produce Merchandiser for Bulk Produce Applications

PWW-E - Refrigerated Island, 86 1/2" Wide
PWWE - Refrigerated Island End Case

Available in 8' and 12' lengths. Contact your sales rep for information on possible availability of additional case lengths.

PWW-E

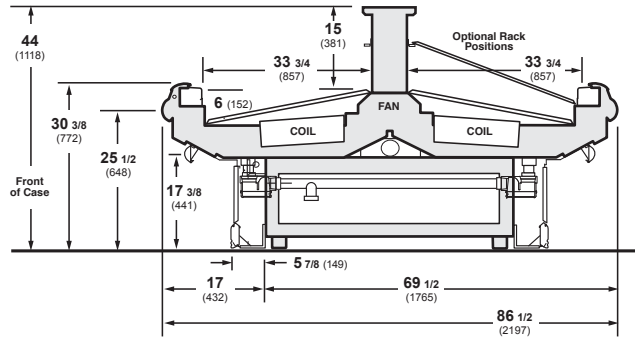

PWWE

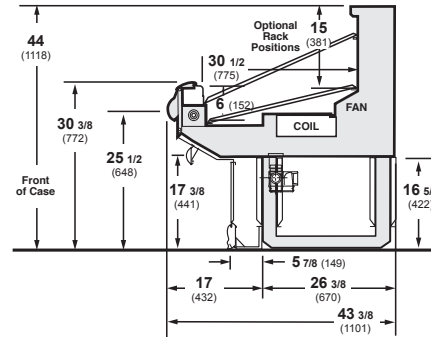

Plan View

PWW-E

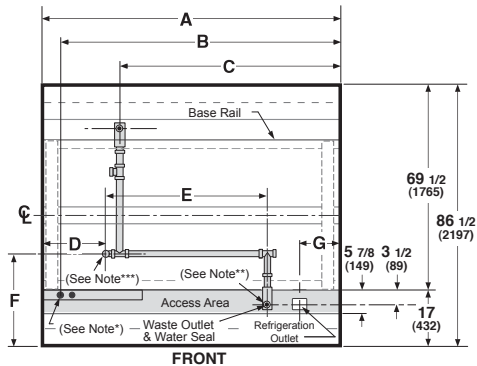

Note:
Maximum outside dimension of case (back-to-front) includes bumper.

PWWE

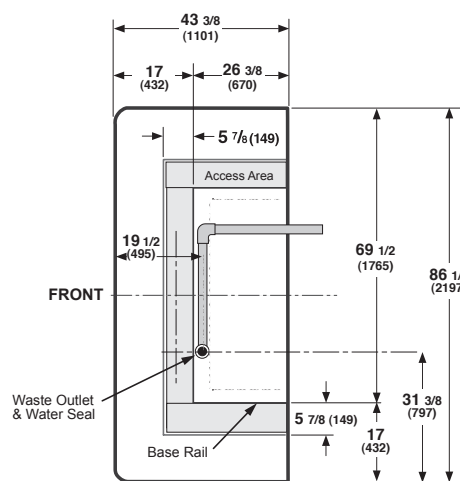

Note:
Maximum outside dimension of case (side-to-side) includes bumper.

Dimensions	4 FT	6 FT	8 FT	12 FT
A	48 1/4 (1226)	72 1/4 (1835)	96 3/8 (2448)	144 1/2 (3670)
B	47 1/4 (1202)	71 1/4 (1810)	95 3/8 (2423)	143 5/8 (3650)
C	24 1/8 (613)	46 5/8 (1184)	72 1/4 (1835)	72 1/4 (1835)
D	20 3/8 (517)	19 1/2 (495)	19 1/2 (495)	68 1/2 (1740)
E	3 3/4 (95)	24 3/4 (629)	51 7/8 (1318)	3 3/4 (95)
F	24 7/8 (632)	25 7/8 (657)	25 7/8 (657)	24 7/8 (632)
G	9 (230)	9 (230)	9 (230)	9 (230)

Note

Use Hussmann's technical data sheets to get precise dimensions for all store layout purposes.

Excellent Refrigeration Performance

Designed for bulk produce applications, the PWR provides dramatic advances in refrigeration performance for produce island displays. A unique coil, center flue and air discharge design forces cold air through products. Produce is kept colder with very stable and consistent temperatures throughout the entire display area. Each end case also has a dedicated coil and fan package to ensure superior refrigeration performance.

Less Refrigerant Needed

Hussmann modular coils require 50% to 60% less refrigerant within the coil than full length coils.

Quick, Easy Cleaning

High impact bottoms with radius corners are easier to clean. Lift-out back panels provide quick access to fan assembly.

Solid Durability

Heavy-duty corner assemblies are designed to stand up to the punishment of daily abuse. True shock absorbing dual bumper system further protects case exterior. Heavy-duty base and skids.

DOE 2017 Energy Efficiency Compliant Hussmann refrigerated merchandisers configured for sale for use in the United States meet or surpass the requirements of the DOE 2017 energy efficiency standards.

NOTE: These merchandisers are designed for use in stores when temperature and humidity do not exceed 75°F and 55% R.H.

NOTE: We reserve the right to change or revise specifications and product design in connection with any feature of our products. Such changes do not entitle the buyer to corresponding changes, improvements, additions, or replacements for equipment previously sold or shipped.

For additional resources, contact your representative or visit www.hussmann.com.

HUSSMANN®

Hussmann Corporation
12999 St. Charles Rock Rd.
Bridgeton, MO 63044-2483
Ph: 314.291.2000

www.hussmann.com