



IC5BL-TE

INSIGHT[®] 5-DECK CONVERTIBLE MERCHANDISER



Dairy



Deli



Produce



Meats



Beverage



ADVANTAGES

- Superior food quality from more stable and uniform product temperatures
- Energy and sustainability benefits through case components
- Better structural integrity from “unibody” constructed design
- Superior merchandising with ellipse and faceted design options



KEY FEATURES

- Case height allows passage through an 82” doorway
- Increased depth for high volume bulk applications
- Low front provides better product visibility
- Lift-up fan plenums and coils in back wall make cleaning and servicing easier
- Seamless plastic “bathtub” bottom helps prevent leaks



IC5BL-TE Insight® 5-Deck Convertible Merchandiser

MERCHANDISING

- Convertible merchandising for multiple applications
- EcoShine II LED lighting standard for optimal product lighting

STORE CONDITIONS

- NSF / ANSI Certified
- Intertek ETL Listed
- DOE 2017 Certified

OPTIONS

- Various glass front, ends, lighting, shelves, and racks
- Two basic bumper styling options, ellipse and faceted
- Flip-up bottom rack for easier cleaning/service
- Options available on most models to adjust performance to Type II climatic conditions

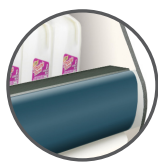

BUMPER
Ellipse



BUMPER
Faceted

TECHNICAL INFORMATION



Scan the QR code with your mobile device to access technical data sheet on hussmann.com

Available with 4', 6', 8', and 12' lengths.

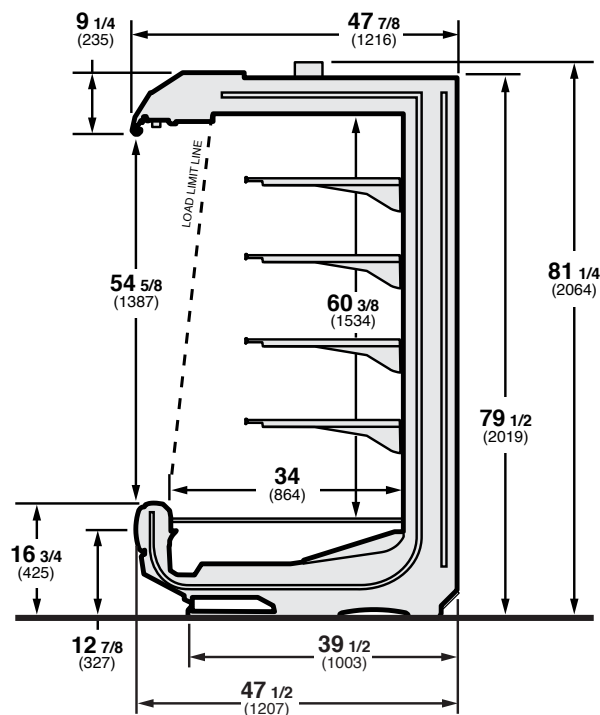

NOTE: These merchandisers are designed for use in stores when temperature and humidity do not exceed 80°F and 55% R.H.

We reserve the right to change or revise specifications and product design in connection with any feature of our products.

Such changes do not entitle the buyer to corresponding changes, improvements, additions, or replacements for equipment previously sold or shipped.

For additional resources, contact your representative or visit www.hussmann.com.

HUSSMANN®

Hussmann Corporation
12999 St. Charles Rock Rd.
Bridgeton, MO 63044-2483
Ph: 800.592.2060

www.hussmann.com