

Insight® Merchandisers



ID5SU

ID5SU, ID5SV

Insight 5-Deck Merchandisers
with Ultra or Very Low Front for Dairy and Deli Applications

Two versatile styling options



CANOPY
Ellipse



CANOPY
Faceted

Hussmann Insight® 5-Deck Merchandisers with Ultra or Very Low Front for Dairy and Deli Applications

ID5SU - Insight, Dairy, 5-Deck, Standard Front-to-Back Depth, Ultra Low Front

ID5SV - Insight, Dairy, 5-Deck, Standard Front-to-Back Depth, Very Low Front

Available in 4', 6', 8' and 12' lengths.

ID5SU

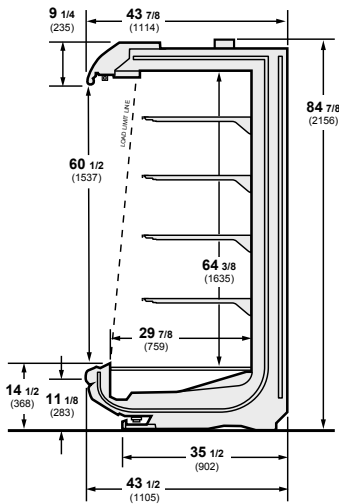

Gross Refrigerated Volume* - **12.1 ft³/ft**
(1.12 m³/m)

*per ANSI/AHRI 1200-2013 appendix C. Volume Calculation

ID5SV

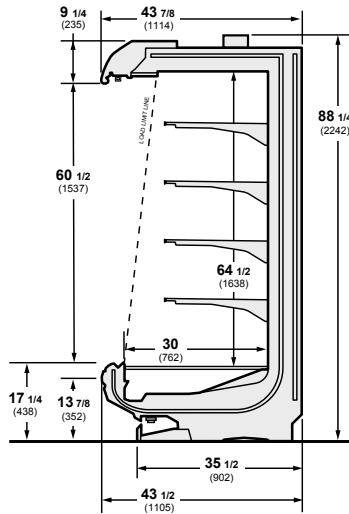

Gross Refrigerated Volume* - **12.1 ft³/ft**
(1.12 m³/m)

*per ANSI/AHRI 1200-2013 appendix C. Volume Calculation

Plan View

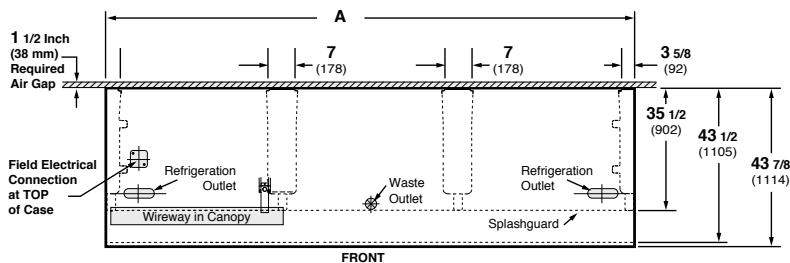

Dimensions	4 FT	6 FT	8 FT	12 FT
A	48 1/8 (1222)	72 1/4 (1835)	96 1/4 (2445)	144 3/8 (3668)

Note: Overall case length without ends or partitions. Contact your sales representative for information on possible availability of additional case lengths.

Note

Use Hussmann's technical data sheets to get precise dimensions for all store layout purposes.

Features / Benefits

- ID5SU and ID5SV cases are designed to maximize product facings and visibility with "very" or "ultra" low fronts
- Superior Food Quality
 - More stable and uniform product temperatures to maintain freshness
 - Shorter defrost cycles protect food integrity
- Energy and Sustainability Benefits
 - 17% case energy savings on average vs. other currently available Hussmann products
 - EcoShine II LED lights standard, up to 71% more efficient than fluorescents
 - Over 30% less refrigerant in coils vs. previous coil designs
- Better Structural Integrity
 - Unibody construction improves integrity, facilitates moving, joining, and setting cases
 - Additional new features simplify installation
- Easier to Clean, Better Sanitation
 - Electrical parts/connections in splash zone can be sprayed with water, rated IP 67
 - New anti-clog drain strainer
 - Coil in back wall and flip-up fan plenums for easy-to-clean case bottom
 - Seamless plastic "bathtub" bottom helps prevent leaks
- Easier Service
 - Wiring raceway in canopy for easy access
 - Flip-up access door on optional bottom rack for easy access to drain, fans and valves
 - Standard LED lights reduce relamping and other maintenance costs
- Superior Merchandising
 - Ellipse and faceted design options to align with store image
 - Convertible merchandising optionally available
 - EcoShine II LED lighting standard, customized for optimal product lighting
 - Improved air curtain reduces "cold aisle" effect by 2-3° F

Options

- Various ends, lighting, shelves, racks, paint and bumper colors
- Two basic canopy styling options, ellipse and faceted, are available
- Unique, high efficiency night curtains
- Flip-up bottom rack for easier cleaning/service
- EcoVision glass doors can be factory installed or field installed after purchase
- Sign-ready canopy fascia panel
- Options available on most models to adjust performance to Type II climatic conditions



Hussmann refrigerated merchandisers configured for sale for use in the United States meet or surpass the requirements of the DOE 2017 energy efficiency standards.

NOTE: These merchandisers are designed for use in stores when temperature and humidity do not exceed 75°F (23.9°C) and 55% R.H.

NOTE: We reserve the right to change or revise specifications and product design in connection with any feature of our products. Such changes do not entitle the buyer to corresponding changes, improvements, additions, or replacements for equipment previously sold or shipped.

Hussmann Corporation

12999 St. Charles Rock Rd.
Bridgeton, MO 63044-2483
Ph: 314.291.2000

www.hussmann.com

HUSSMANN®