

# HUSSmann®

## *ISLA Flexible Island* Merchandiser



## *Installation & Operation Manual*

Shipped with Technical Data Sheets

P/N\_0561895\_E



## BEFORE YOU BEGIN

Read these instructions completely and carefully.



### ANSI Z535.5 DEFINITIONS

- **DANGER** – Indicate[s] a hazardous situation which, if not avoided, will result in death or serious injury.
- **WARNING** – Indicate[s] a hazardous situation which, if not avoided, could result in death or serious injury.
- **CAUTION** – Indicate[s] a hazardous situation which, if not avoided, could result in minor or moderate injury.
- **NOTICE** – Not related to personal injury – Indicates[s] situations, which if not avoided, could result in damage to equipment.

The information contained in this document is the property of Hussmann Corporation and shall not be used in whole or in part without written permission.

### **WARNING**

Proper Field Wiring and Grounding Required!  
Failure to follow code could result in death or serious injury. All field wiring **MUST** be performed by qualified personnel. Improperly installed and grounded field wiring poses **FIRE** and **ELECTROCUTION** hazards. To avoid these hazards, you **MUST** follow requirements for field wiring installation and grounding as described in NEC and your local/state electrical codes.

### **WARNING**

#### **PERSONAL PROTECTION EQUIPMENT (PPE)**

Only qualified personnel should install and service this equipment. Personal Protection Equipment (PPE) is required whenever installing or servicing this equipment. Always wear appropriate PPE as required by OSHA regulations, as well as all other federal, state and local codes. PPE may include, but is not limited to, safety glasses, gloves, protective boots or shoes, long pants, and a long-sleeve shirt. Observe all precautions on tags, stickers, labels and literature attached to this equipment.

### **CAUTION**

This manual was written in accordance with originally prescribed equipment that is subject to change. Hussmann reserves the right to change all or part of the equipment for future stores such as, but not limited to, controllers and electrical specifications.

### **WARNING**

#### **— LOCK OUT / TAG OUT —**

To avoid serious injury or death from electrical shock, always disconnect the electrical power at the main disconnect when servicing or replacing any electrical component. This includes, but is not limited to, such items as controllers, electrical panels, condensers, lights, fans, and heaters.

---

## 2. Table of Contents

1.General Instructions.....	iv
2.Table of Contents .....	iii
3.Cut and Plan Views .....	1
4. Installation.....	2
5. Plumbing .....	11
6. Refrigeration .....	16
7. Electrical.....	18
8.Electrical Wiring Diagrams Index.....	25
9.Electrical Wiring Diagrams .....	26
10.User Information.....	55
11.Shelf Weight Limits .....	56
12. Maintenance.....	57
Maintenance (Cont'd) .....	58
13.Troubleshooting Guide .....	59
14. Appendices .....	61
Appendix A. - Temperature Guidelines .....	61
Appendix B. - Application Recommendations .....	61
Appendix C. - Field Recommendations.....	61
Appendix D. - Recommendations to User.....	62

---

**IMPORTANT**  
**KEEP THIS DOCUMENT IN YOUR STORE FOR FUTURE REFERENCE**

*Quality that sets industry standards!*

**HUSSMANN<sup>®</sup>**

12999 St. Charles Rock Road • Bridgeton, MO 63044-2483

U.S. & Canada 1-800-922-1919 • Mexico 800-890-2900

[www.hussmann.com](http://www.hussmann.com)

© 2024 Hussmann Corporation

---

# 1. General Instructions

## IMPORTANT

**KEEP THIS DOCUMENT IN YOUR STORE FOR FUTURE REFERENCE**

# HUSSMANN®

13770 Ramona Avenue  
Chino, California 91710  
(909) 628-8942 FAX  
(909) 590-4910

12999 St. Charles Rock Road  
Bridgeton, MO 63044-2483  
U.S. & Canada  
1-800-922-1919

**This Booklet Contains Information on:** ISLA Flexible Island

### Shipping Damage

All equipment should be thoroughly examined for shipping damage before and during unloading.

This equipment has been carefully inspected at our factory and the carrier has assumed responsibility for safe arrival. If damaged, either apparent or concealed, claim must be made to the carrier.

### Apparent Loss or Damage

If there is an *obvious loss or damage*, it must be noted on the freight bill or express receipt and signed by the carrier's agent; otherwise, carrier may refuse claim. The carrier will supply necessary claim forms.

### Concealed Loss or Damage

When loss or damage *is not apparent until after equipment is uncrated*, a claim for concealed damage is made. Make request in writing to carrier for inspection within 15 days, and retain all packaging. The carrier will supply inspection report and required claim forms.

### Shortages

Check your shipment for any possible shortages of material. If a shortage should exist and is found to be the responsibility of Hussmann, *notify Hussmann*. If such a shortage involves the carrier, *notify the carrier immediately*, and request an inspection. Hussmann will acknowledge shortages within ten days from receipt of equipment.

### Hussmann Product Control

The serial number and shipping date of all equipment has been recorded in Hussmann's files for warranty and replacement part purposes. All correspondence pertaining to warranty or parts ordering must include the serial number of each piece of equipment involved, in order to provide the customer with the correct parts.

***Keep this booklet with the case at all times for future reference.***

## General Instructions Continued

### UNLOADING FROM TRAILER:

Lever Bar  
*(also known as a Mule, Johnson Bar, J-bar, Lever Dolly,  
 and pry lever)*  
 Moving Dolly



### REVISION HISTORY

#### REVISION E

1. Updated nomenclatures, data sheets, and lifting and transport instructions for IMX cases

#### REVISION D

1. Added Coil Cleaning note

Original Issue



This warning does not mean that Hussmann products will cause cancer or reproductive harm, or is in violation of any product-safety standards or requirements. As clarified by the California State government, Proposition 65 can be considered more of a ‘right to know’ law than a pure product safety law. When used as designed, Hussmann believes that our products are not harmful. We provide the Proposition 65 warning to stay in compliance with California State law. It is your responsibility to provide accurate Proposition 65 warning labels to your customers when necessary. For more information on Proposition 65, please visit the California State government website.



### 3. Cut and Plan Views

**IM-04-ED5-R**  
Deeper base, Extended Canopy

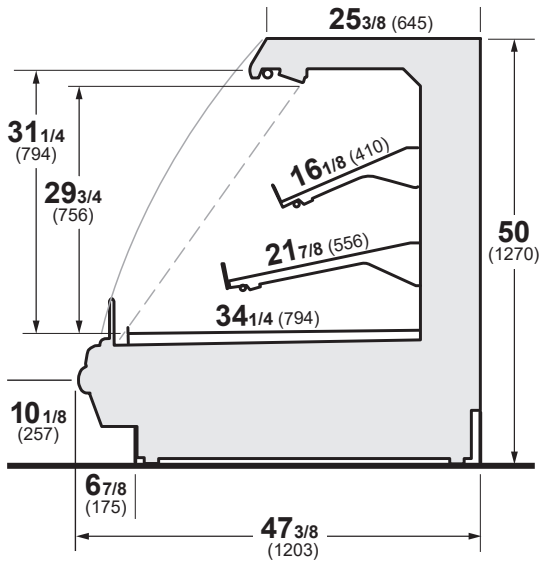

**IM-04-R / IMX4-R**  
Refrigerated Self-Service Module

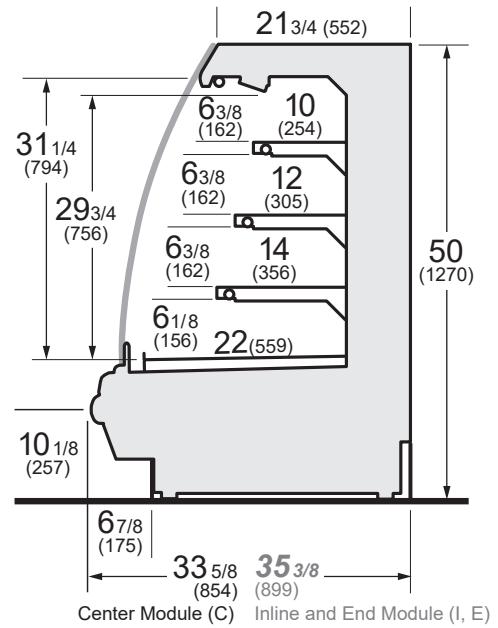

**IM-05-R / IMX-5R**  
Refrigerated Self-Service Module

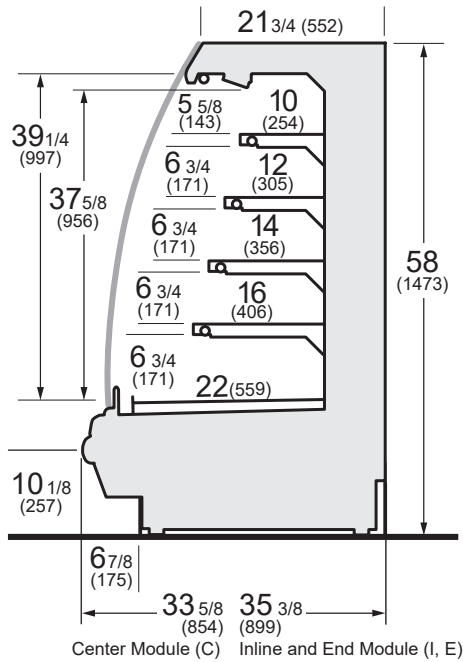

**IM-C5-R Center Module / IM-I5-R In-line Module**

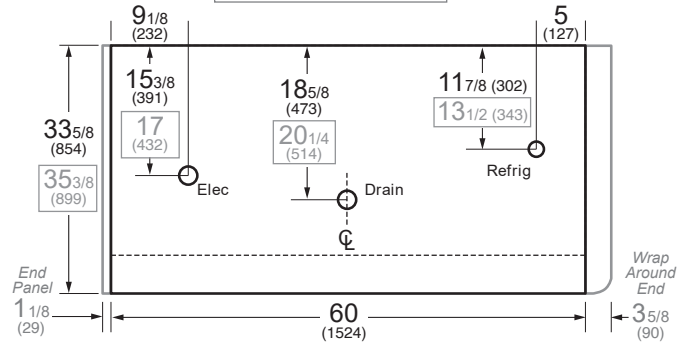

**IM-04-E5-R, IM-05-E5-R / IMX4E5-R, IMX5ES-R End Module**

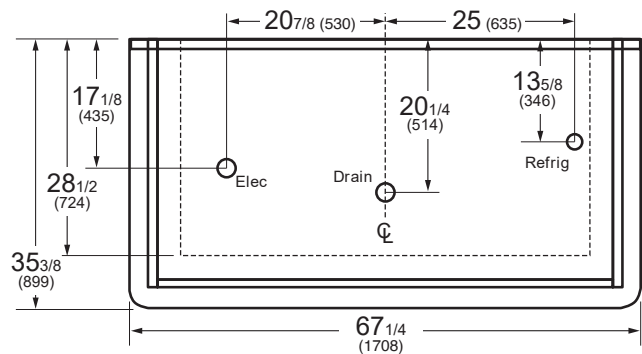

## 4. Installation

### Location

The refrigerated merchandisers have been designed for use only in air conditioned stores where temperature and humidity are maintained at or below 75°F and 55% relative humidity. DO NOT allow air conditioning, electric fans, ovens, open doors or windows (etc.) to create air currents around the merchandiser, as this will impair its correct operation.



### Uncrating the Stand

Place the fixture as close to its permanent position as possible. Remove the top of the crate. Detach the walls from each other and remove from the skid. Unbolt the case from the skid. The fixture can now be lifted off the crate skid. **Lift only at base of stand!**

### Exterior Loading

These models have not been structurally designed to support excessive external loading. **Do not walk on their tops;** This could cause serious personal injury and damage to the fixture.

### Setting and Joining

The sectional construction of these models enable them to be joined in line to give the effect of one continuous display. A joint trim kit is supplied with each joint.



### Leveling

**IMPORTANT! IT IS IMPERATIVE THAT CASES BE LEVELED FROM FRONT TO BACK AND SIDE TO SIDE PRIOR TO JOINING. A LEVEL CASE IS NECESSARY TO INSURE PROPER OPERATION, WATER DRAINAGE, GLASS ALIGNMENT AND OPERATION OF THE HINGES SUPPORTING THE GLASS. LEVELING THE CASE CORRECTLY WILL SOLVE MOST HINGE OPERATION PROBLEMS.**

- Note:**
- A. To avoid removing concrete flooring, begin lineup leveling from the highest point of the store floor.
  - B. When wedges are involved in a lineup, set them first.

### ISLA Body Panel Removal and Installation

#### Transportation:

All Lower and Bottom Body panels on the ISLA should be removed for extended transportation (jacking, lifting, crating, etc.)

#### Service:

For most service applications (drains, piping, electrical), only the Bottom Body panels need removal. Removing both panels may be more convenient.

- Note:** The Bumper and Price Tag Extrusion should only be serviced by a trained installation professional. Incorrect servicing will result in damage.



This warning does not mean that Hussmann products will cause cancer or reproductive harm, or is in violation of any product-safety standards or requirements. As clarified by the California State government, Proposition 65 can be considered more of a 'right to know' law than a pure product safety law. When used as designed, Hussmann believes that our products are not harmful. We provide the Proposition 65 warning to stay in compliance with California State law. It is your responsibility to provide accurate Proposition 65 warning labels to your customers when necessary. For more information on Proposition 65, please visit the California State government website.



### ISLA Lifting and Transport Instructions

1. The ISLA can be lifted using J-Bars, use the specified jacking points to raise the case.
2. Raise one side of the case first and when the space is enough insert the J-Bar on the other side.
3. Use as many J-Bars as possible to lift from the end shipping brace, minimum of 2 J-Bars is required.
4. The ISLA can be raised at one end with the J-Bar to allow the placement of rollers or dollies.
5. Place Dollies and chock wheels before lifting the other side. Be sure that the dollies are evenly spaced to carry to weight of the case
6. Drag or push the case only touching the brace shipping or the dollies. Avoid any component including glass component.

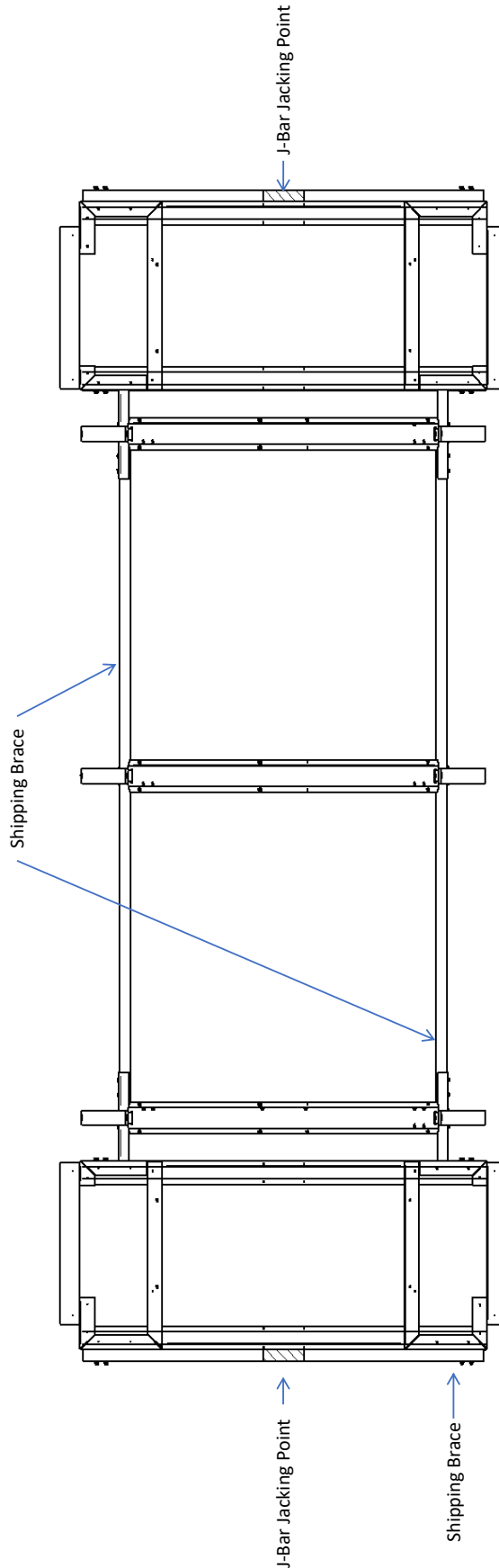

IMX4C8 & IMX4E32D CASES



# Installation (Cont'd)

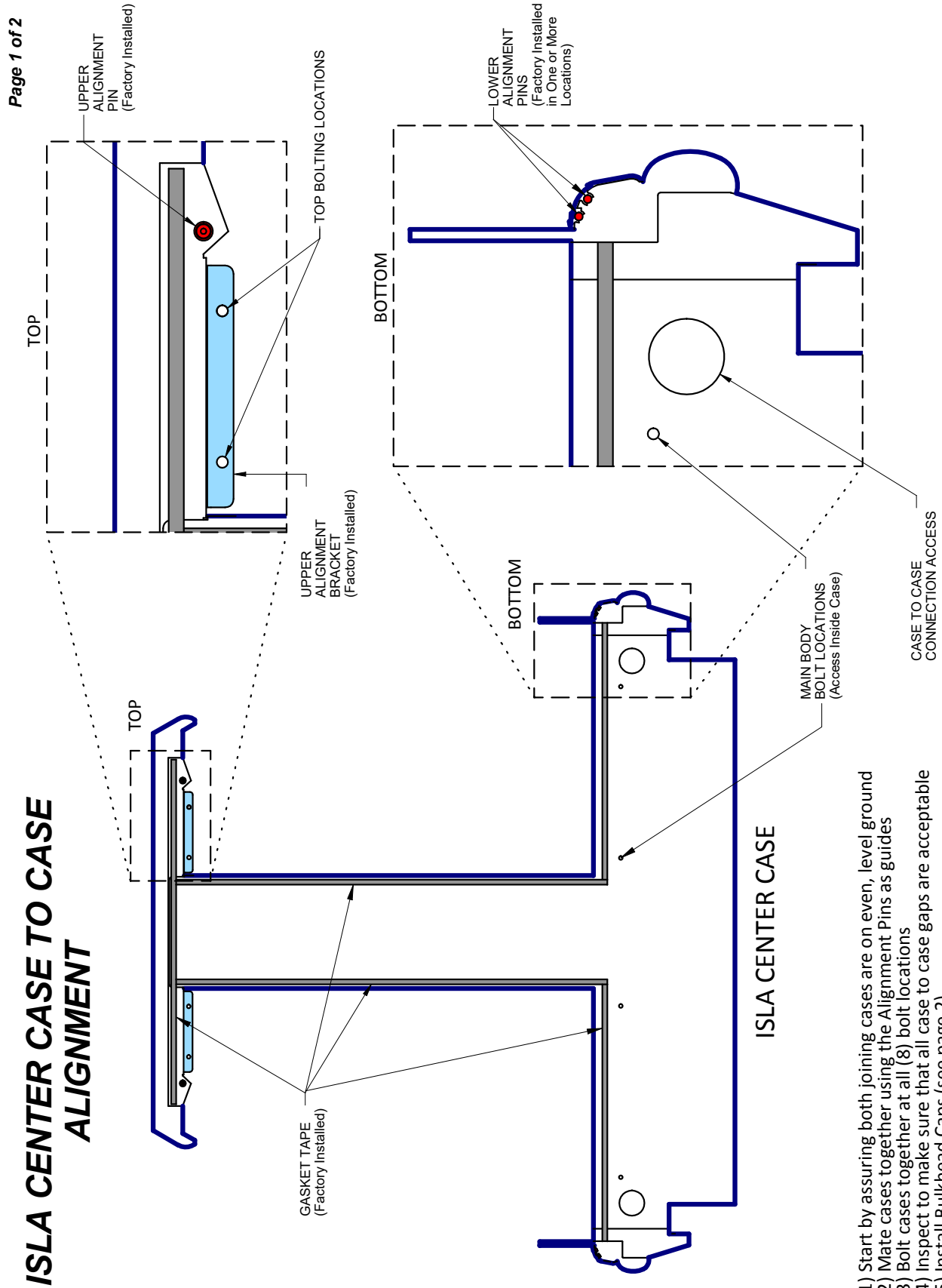

- (1) Start by assuring both joining cases are on even, level ground
- (2) Mate cases together using the Alignment Pins as guides
- (3) Bolt cases together at all (8) bolt locations
- (4) Inspect to make sure that all case to case gaps are acceptable
- (5) Install Bulkhead Caps (see page 2)
- (6) Install Top and Fascia Joint Trim

# ISLA CENTER CASE TO CASE ALIGNMENT Bulkhead Cap Installation

## Installation (Cont'd)

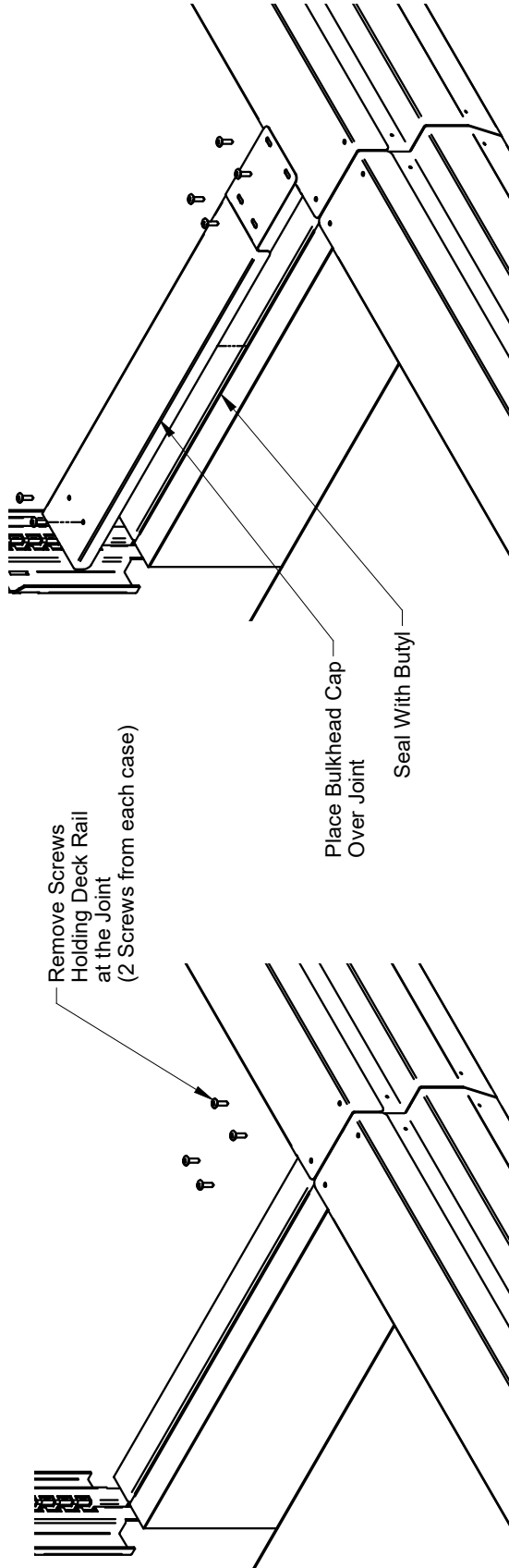

FIRST

NEXT

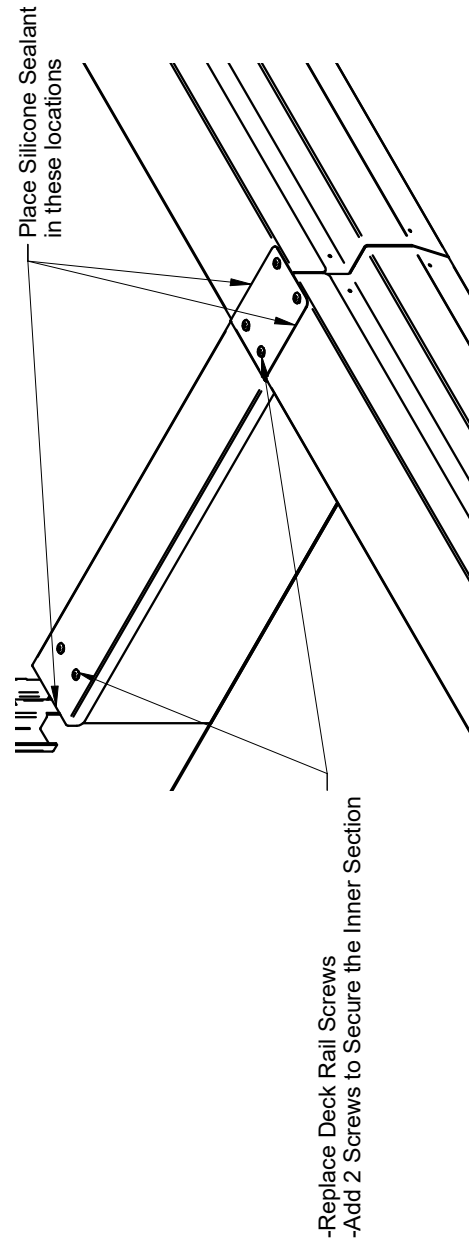

FINALLY

## Installation (Cont'd)

### ISLA Transportation Guidelines



1. Do Not Push, Pull, Adjust, or Manipulate the ISLA case by any glass component .
  - Doing so will result in severe damage to such components
  - Glass Breakage may result in serious injury
  - See lifting and transport instructions for proper moving technique
2. Never stand on the ISLA Top, Deck, or any Shelves for any reason.
 

These surfaces are not steps and are not designed to support such loads.

  - Misusing these surfaces as steps will result in damage to the case
  - Misusing these surfaces as steps may result in serious injury to the user
  - These surfaces are intended for the storage and merchandising of food products
  - Use a ladder or designed structure to work above the case

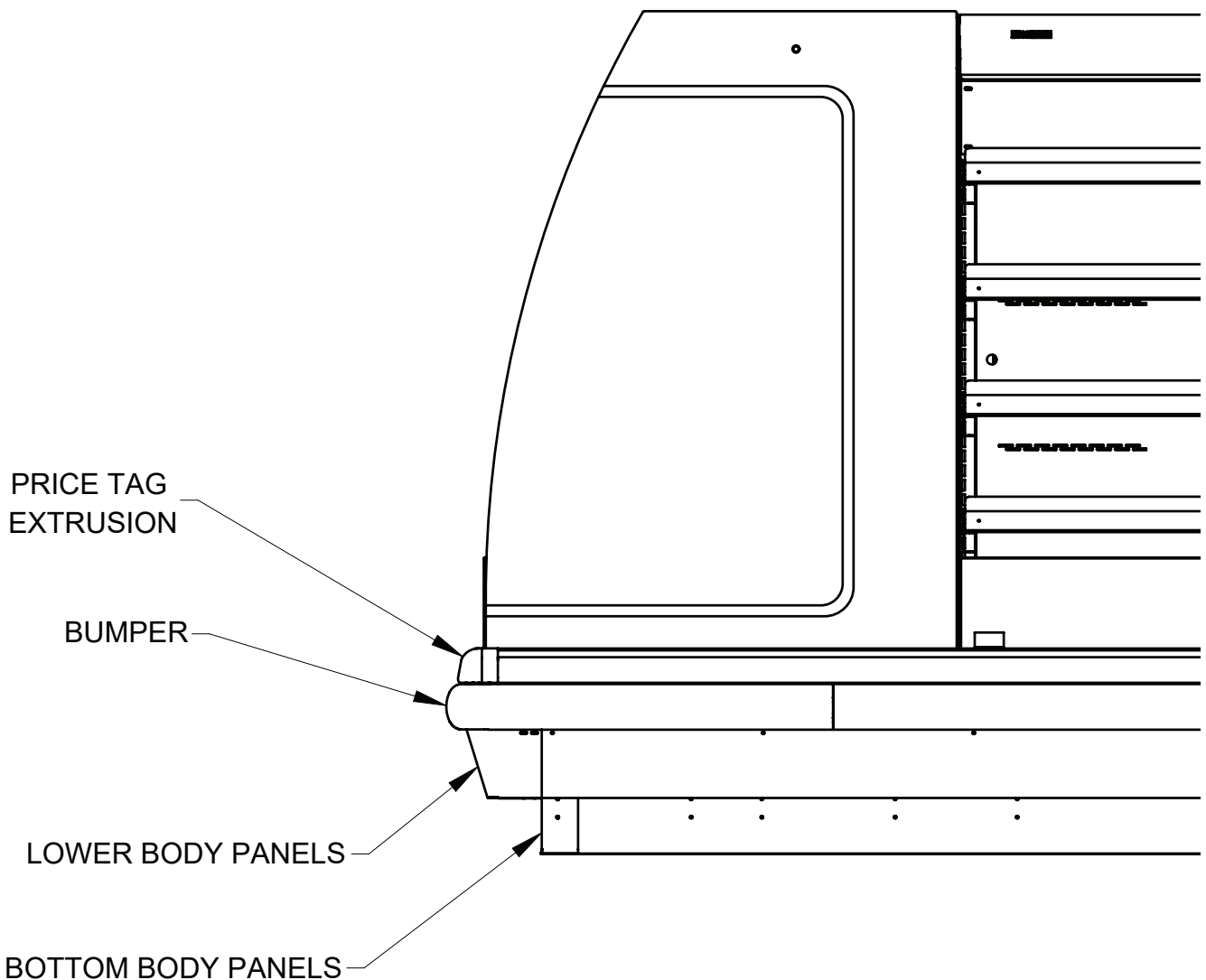

# Installation (Cont'd)

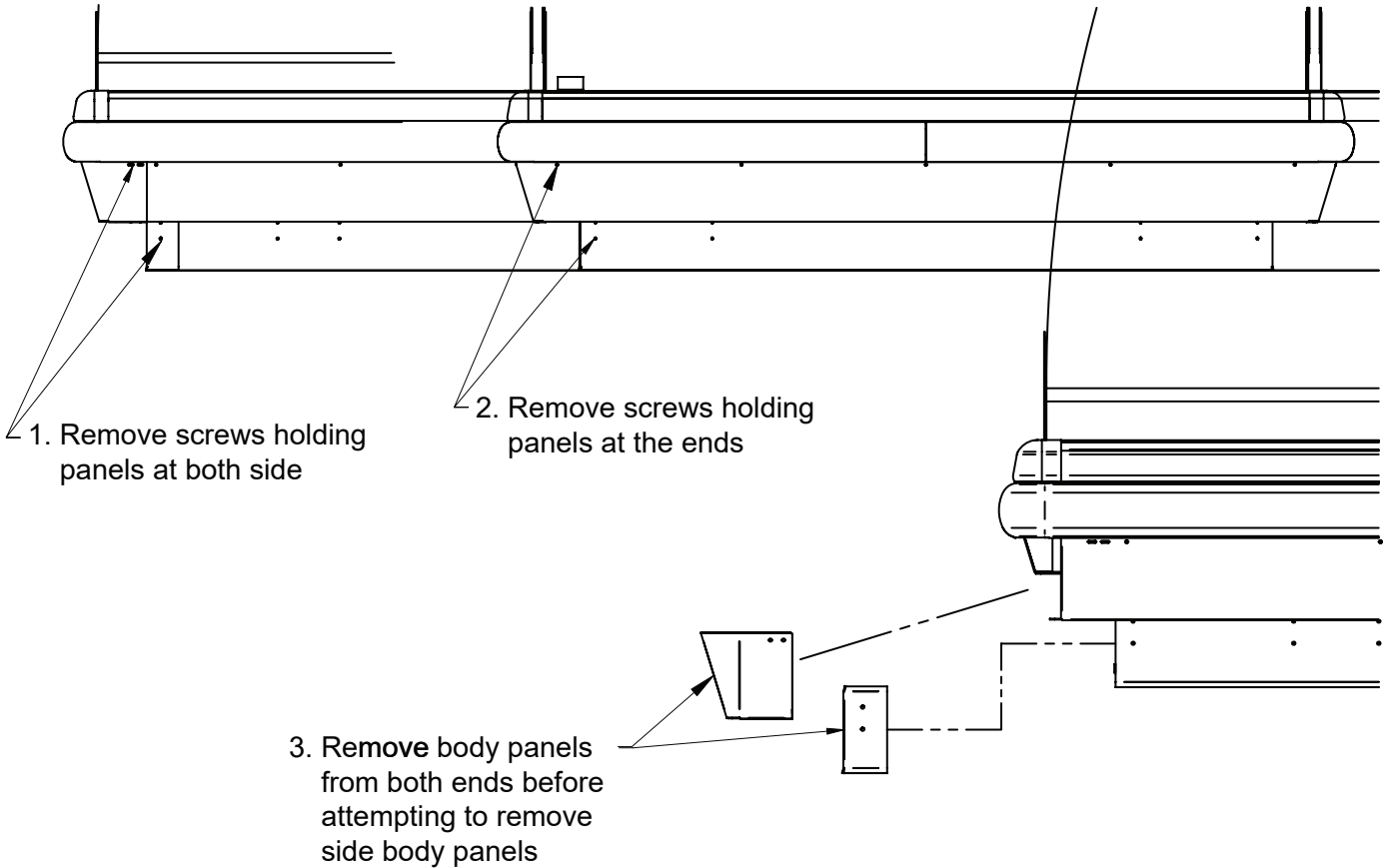

Note: The Lower and Bottom body panels can be removed independent of each other

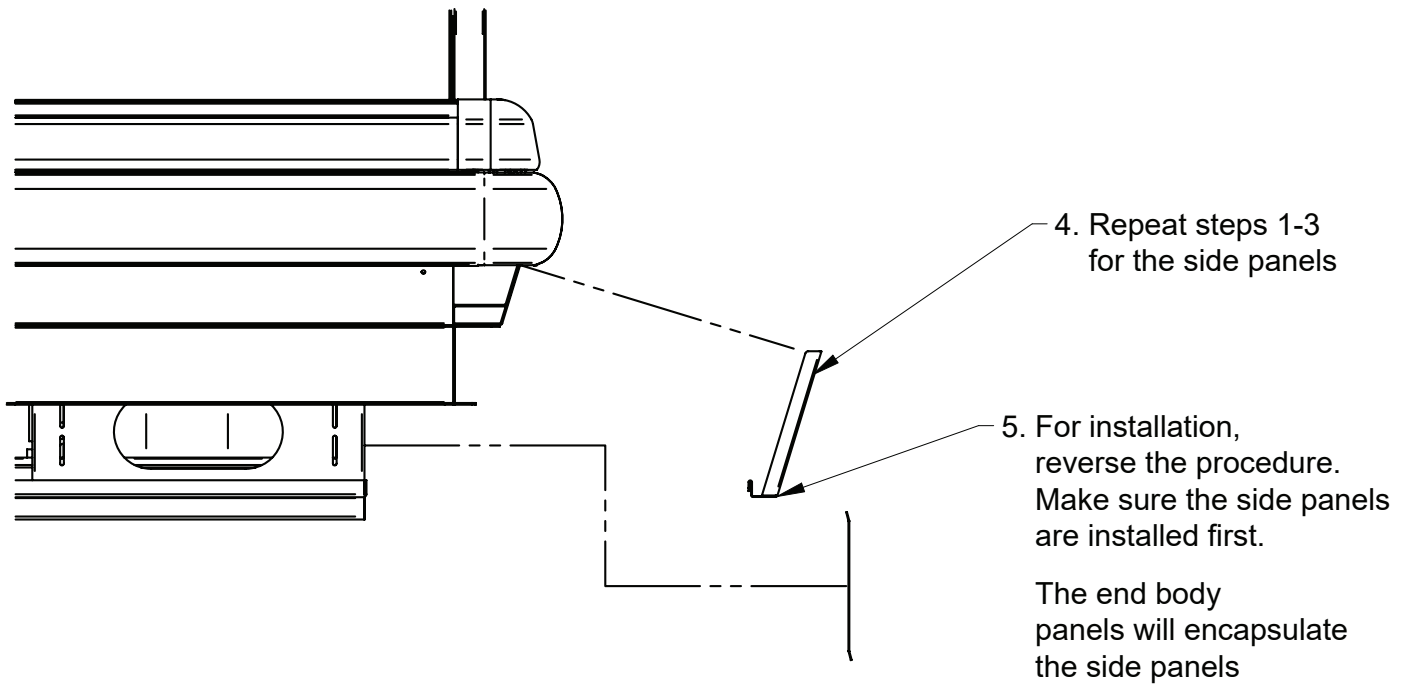

Note that lower side of the lower body panels must be properly placed around mounting surface to ensure proper fit.

## Installation (Cont'd)

### ISLA Sump Pump Service Instructions

**Note:** Before attempting to service the sump pump and drain components, refer to the ISLA BODY PANEL REMOVAL and INSTALLATION GUIDE.

The Bottom (and possibly Lower) panels must be removed to allow access for servicing.

The Drain Sump will be full of drainwater. Use the appropriate Personal Protective Equipment (Gloves, Goggles, Sleeves, etc.) during removal.

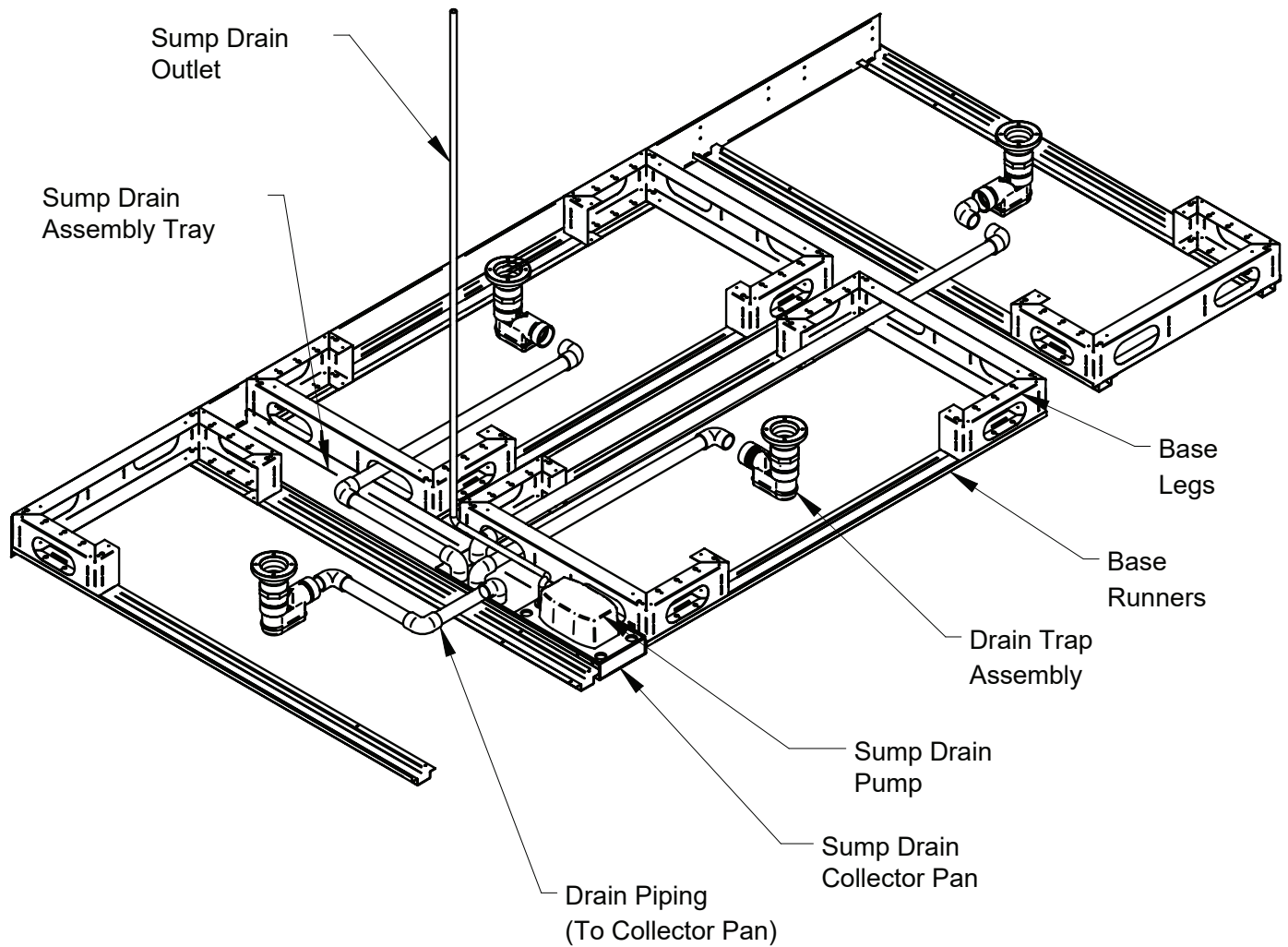

# Installation (Cont'd)

**Note:** The drainage system is always active, but sees most activity during defrost. If the refrigeration cannot be stopped, work on the drainage system between defrost periods.

1. Unplug Sump Pump (Not Pictured)

**WARNING:**

Servicing the drainage system with the sump pump energized may result in electrical shock!

2. Lift and remove (4) drain pipes from collector pan

Use a basin or shallow container as temporary sump while servicing.

3. Disconnect sump drain outlet from pump

The fitting will be either barbed or hose clamp

4. Slide Collector pan out from Assembly Tray

5. Empty collector pan and clear debris.

Wash with soapy water

Add condensate pan treatment tablet after each wash (e.g. Pro Treat 151 tablets)

6. Reverse procedure to reassemble

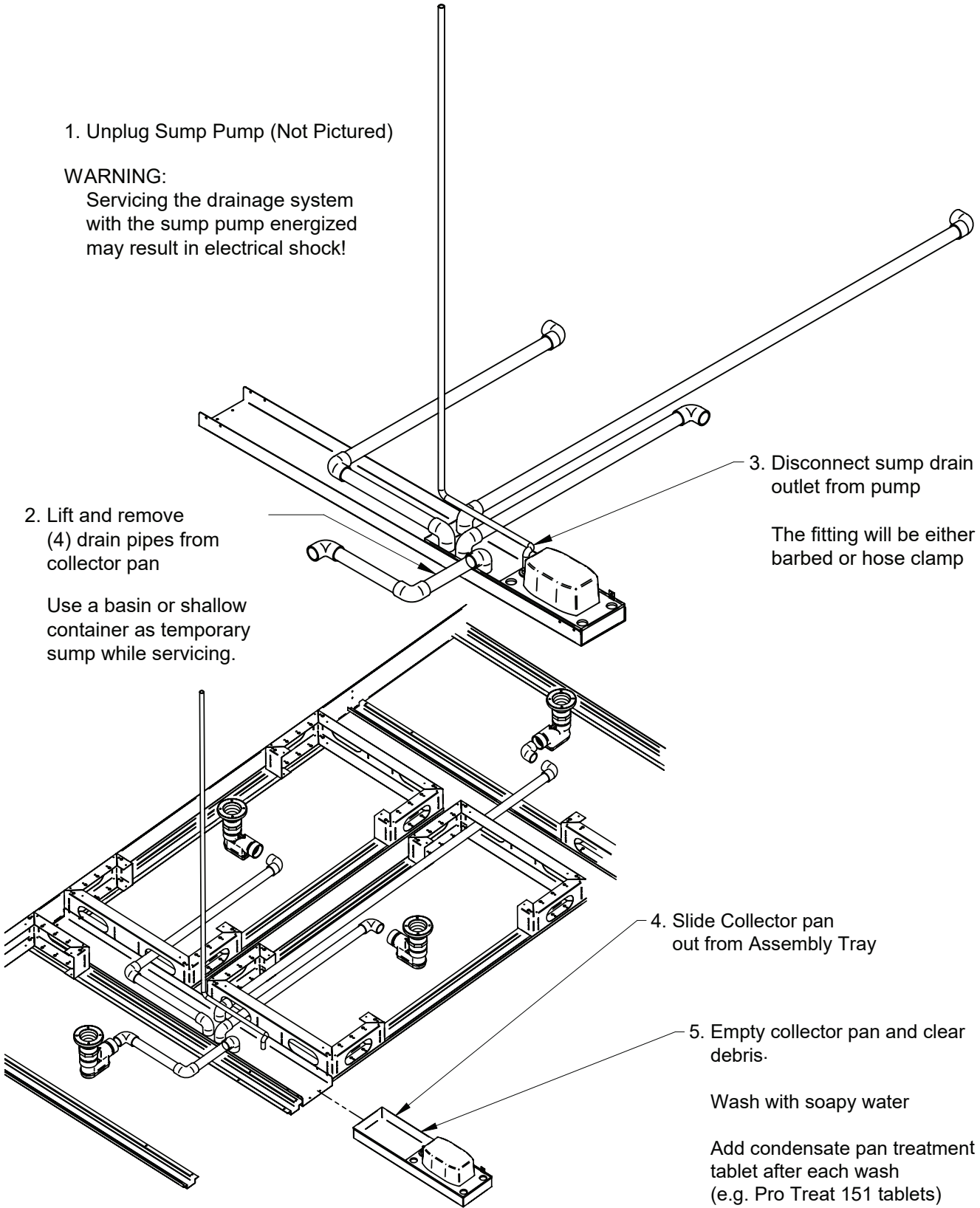



## 5. Plumbing

### Waste Outlet and P-TRAP

The waste outlet is located in the center, 8" from the front of the case.

A 1 1/2" P-TRAP and threaded adapter are supplied with each fixture. The P-TRAP must be installed to prevent air leakage and insect entrance into the fixture.

**NOTE:** PVC-DWV solvent cement is recommended. Follow the Hussmann's instructions.

### Installing Condensate Drain

Poorly or improperly installed condensate drains can seriously interfere with the operation of this refrigerator and result in costly maintenance and product losses. Please follow the recommendations listed below when installing condensate drains to insure a proper installation:

1. Never use pipe for condensate drains smaller than the nominal diameter of the pipe or P-TRAP supplied with the case.
2. When connecting condensate drains, the P-TRAP must be used as part of the condensate drain to prevent air leakage or insect entrance. Store plumbing system floor drains should be at least 14" off the center of the case to allow use of the P-TRAP pipe section. Never use two water seals in series in any one line. Double P-TRAPS in series will cause a lock and prevent draining.
3. Always provide as much down hill slope ("fall") as possible; 1/8" per foot is the preferred minimum. PVC pipe, when used, must be supported to maintain the 1/8" pitch and to prevent warping.
4. Avoid long runs of condensate drains. Long runs make it impossible to provide the "fall" necessary for good drainage.
5. Provide a suitable air break between the flood rim of the floor drain and outlet of condensate drain. 1" is ideal.
6. Prevent condensate drains from freezing:
  - a. Do not install condensate drains in contact with non-insulated suction lines. Suction lines should be insulated with a nonabsorbent insulation material such as Armstrong's Armaflex.
  - b. Where condensate drains are located in dead air spaces (between refrigerators or between a refrigerator and a wall), provide means to prevent freezing. The water seal should be insulated to prevent condensation.

### ISLA (Self Contained)

The waste outlet and P-TRAP are the same as the remote except hot air from the condenser is forced through the water evap assembly, evaporating the water.

# Plumbing (Cont'd)

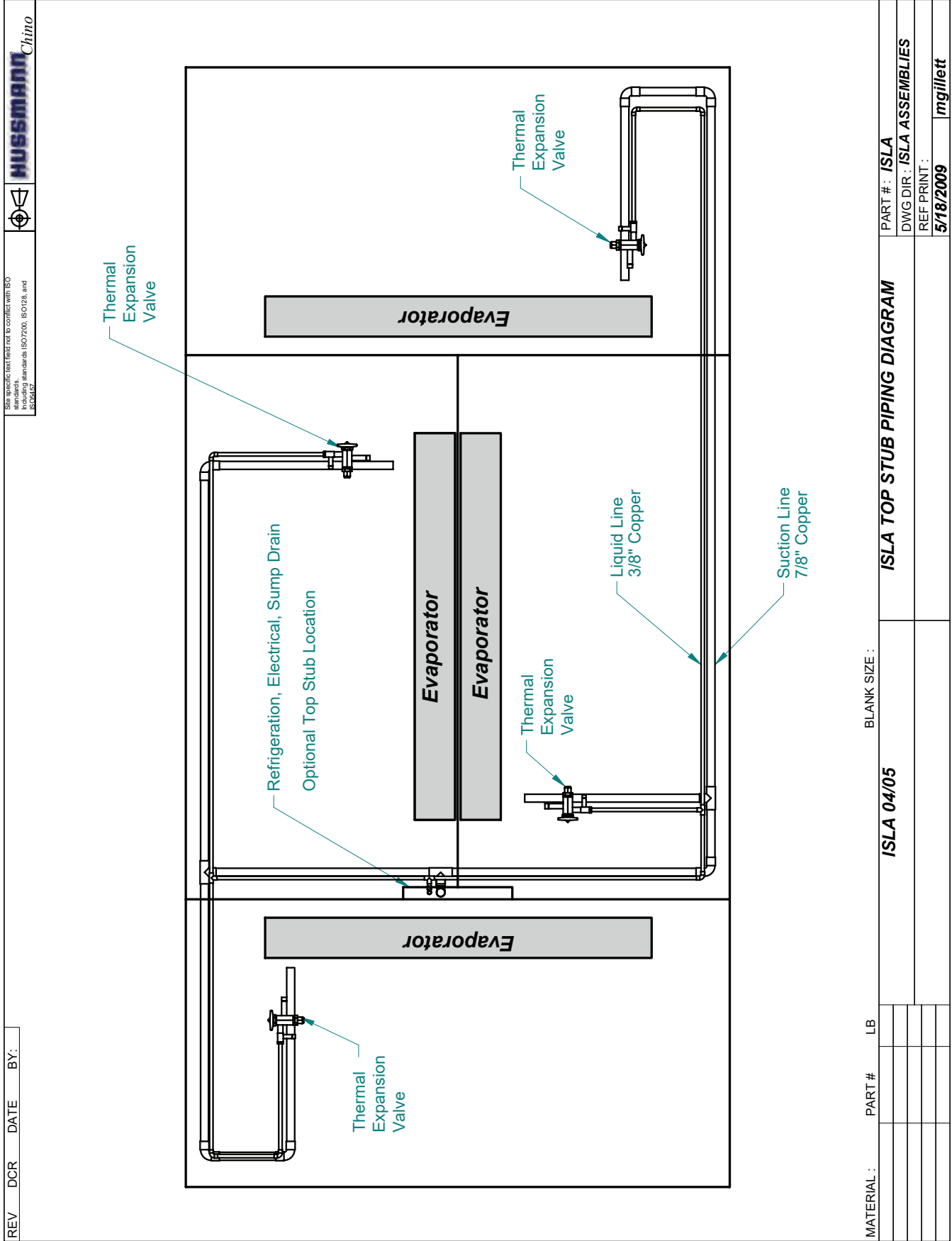

# Plumbing (Cont'd)

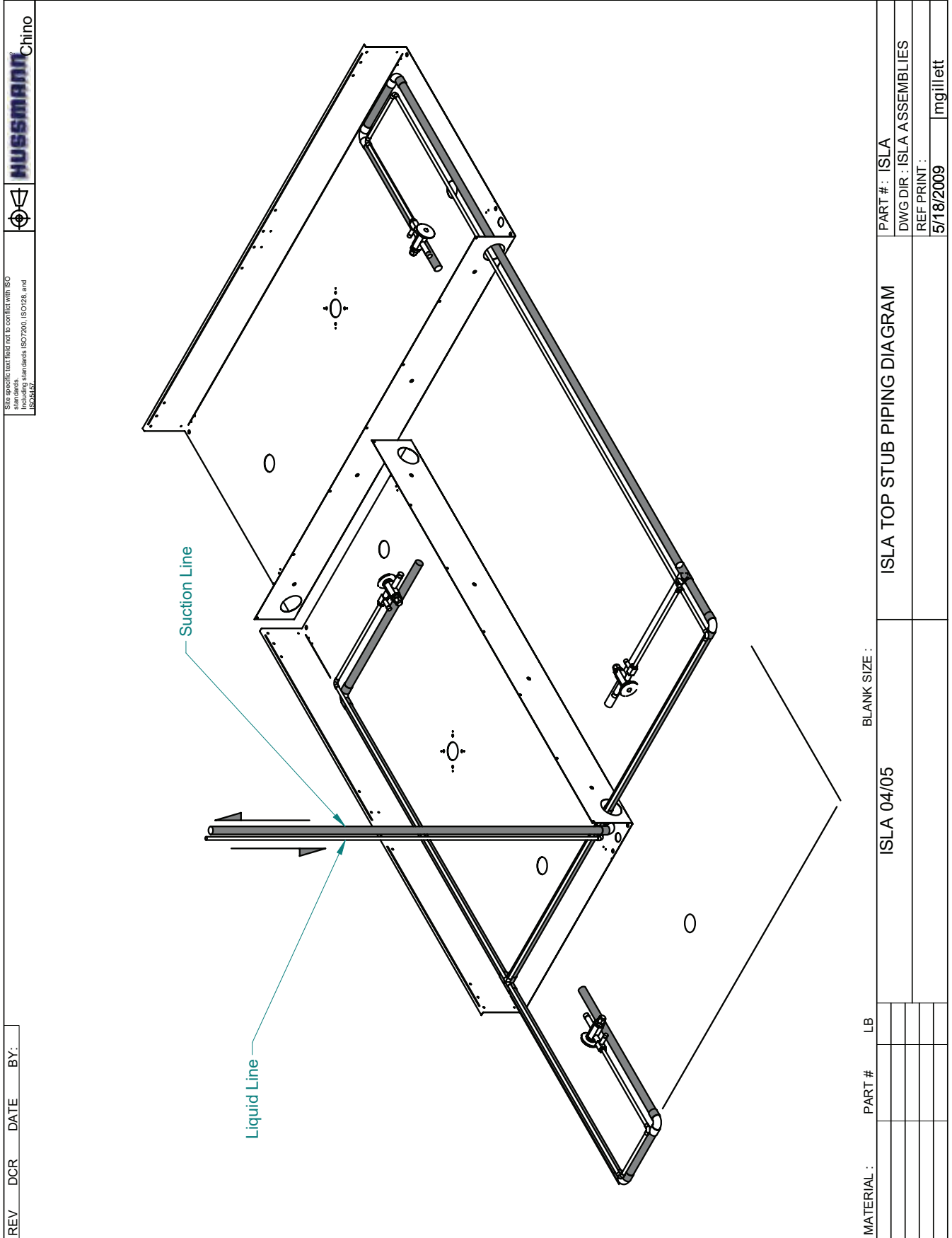

Site specific text field not to conflict with ISO including standards ISO7200, ISO1218, and ISO5467

REV DCR DATE BY:

MATERIAL :	PART #	LB	ISLA 04/05	ISLA TOP STUB PIPING DIAGRAM	PART # : ISLA
					DWG DIR : ISLA ASSEMBLIES
					REF PRINT :
					5/18/2009
					mgjillett

# Plumbing (Cont'd)

Site specific text field not to conflict with ISO standards. ISO standards: ISO 7240, ISO 7241, and ISO 7242.



REV DCR DATE BY:

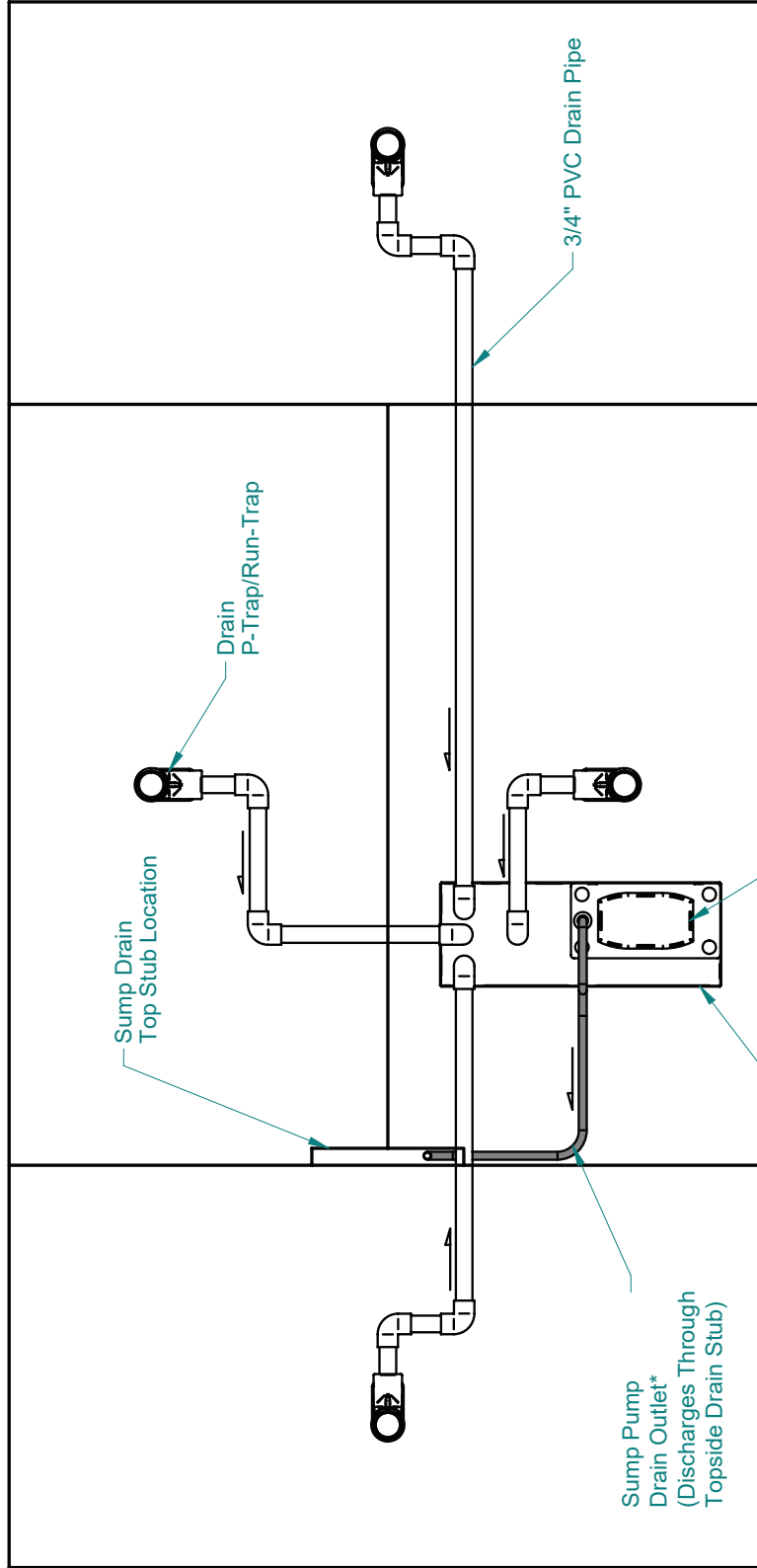

\*Note: Pan and Pump Location may be different from indicated depending on base legs.

Drain Sump Pan\*  
Drain Sump Pump\*

Sump Pump Drain Outlet\* (Discharges Through Topside Drain Stub)

MATERIAL :	PART #	LB	BLANK SIZE :	ISLA 04/05	ISLA TOP STUB PIPING DIAGRAM	PART # : ISLA
						DWG DIR : ISLA ASSEMBLIES
						REF PRINT :
						5/18/2009
						mgillett

# Plumbing (Cont'd)

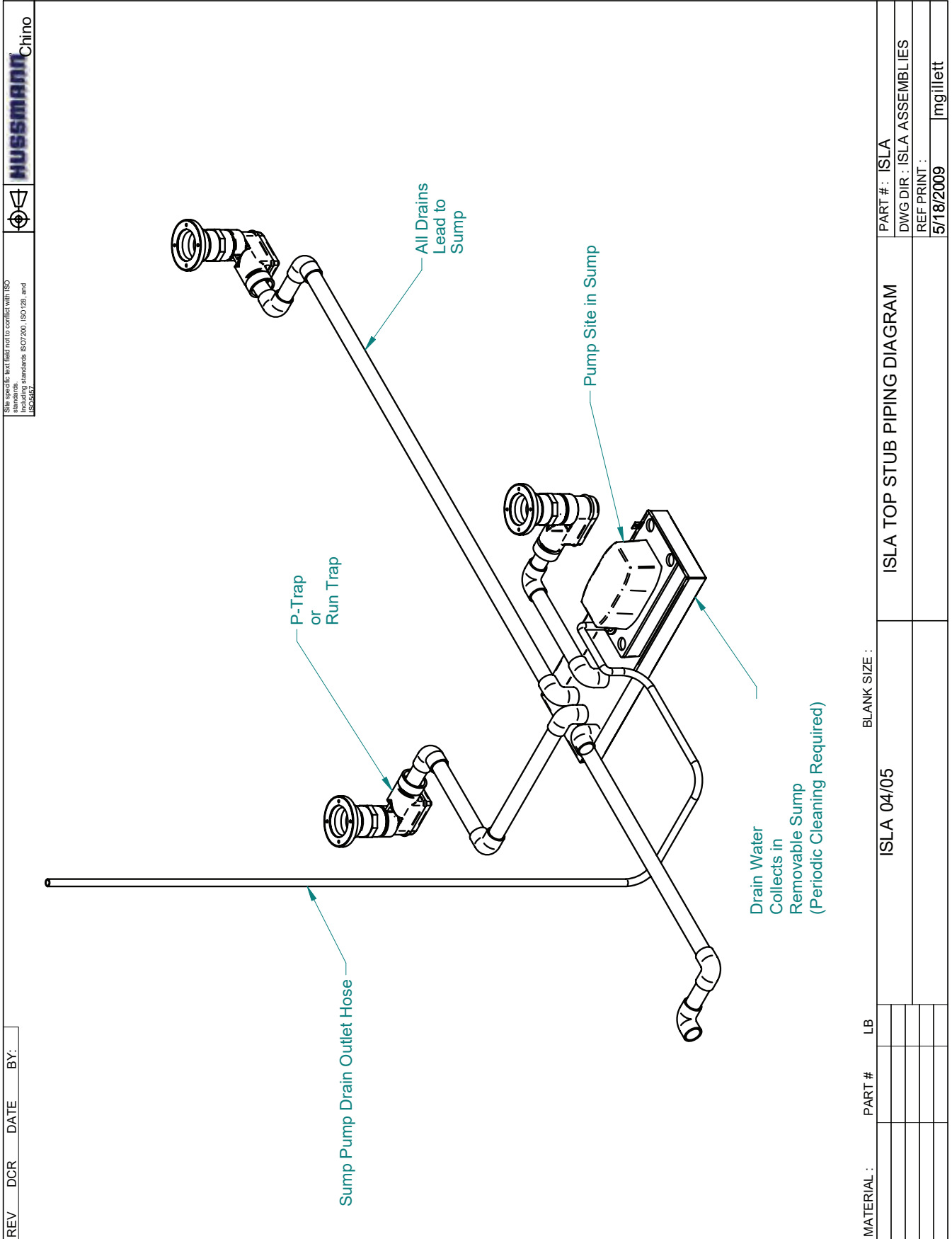

Site specific text (field) not to conflict with ISO including standards ISO 7200, ISO 128, and ISO 5457



ISO 7200, ISO 128, and ISO 5457

REV DCR DATE BY:

MATERIAL :	PART #	LB	ISLA 04/05	ISLA TOP STUB PIPING DIAGRAM	PART # : ISLA
					DWG DIR : ISLA ASSEMBLIES
					REF PRINT :
					5/18/2009
					mgillett

## 6. Refrigeration

### Refrigerant Type

The standard refrigerant will be R-404A unless otherwise specified on the customer order. Check the serial plate on the case for information.

### Piping

The refrigerant line outlets are located under the case. Locate first the electrical box, the outlets are then on the same side of the case, but at the opposite end. Insulate suction lines to prevent condensation drippage.

### Refrigeration Lines

Liquid	Suction
3/8" O.D.	5/8" O.D.

**NOTE:** The standard coil is piped at 5/8" (suction); however, the store tie-in may vary depending on the number of coils and the draw the case has. Depending on the case setup, the connecting point in the store may be 5/8", 7/8", or 1 1/8". Refer to the particular case you are hooking up.

Refrigerant lines should be sized as shown on the refrigeration legend furnished by the store. Install P-TRAPS (oil traps) at the base of all suction line vertical risers. Pressure drop can rob the system of capacity. To keep the pressure drop to a minimum, keep refrigerant line run as short as possible, using the minimum number of elbows. Where elbows are required, use long radius elbows only.

### Control Settings

Maintain these parameters to achieve near constant product temperatures. Product temperature should first be measured in the morning, after having been refrigerated overnight.

### Access to TX Valves and Drain Lines

**MECHANICAL** - Remove product from left end of case. Remove product racks. Remove refrigeration and drain access panels (labeled). TX valve (mechanical only) and drain are located under the pans within the case.

**ELECTRONIC** - The electronic expansion valve master and slave cylinder(s) are located within the electrical access panel(s) in the rear of case. Rear panels lift up and out.

### Electronic Expansion Valve (Optional)

A wide variety of electronic expansion valves and case controllers can be utilized. Please refer to EEV and controller Hussmann's information sheet. Sensors for electronic expansion valves will be installed on the coil inlet, coil outlet and in the discharge air. (Some supermarkets require a 4th sensor in the return air). Case controllers will be located in the electrical raceway or under the case.

### Thermostatic Expansion Valve Location

An Alco balanced port expansion valve model is furnished as standard equipment, unless otherwise specified by customer. There is one expansion valve located on the right side of each evaporation coil under the bottom deck pans.

### Expansion Valve Adjustment

Expansion valves must be adjusted to fully feed the evaporator. Before attempting any adjustments, make sure the evaporator is either clear or very lightly covered with frost, and that the fixture is within 10°F of its expected operating temperature.

### Measuring the Operating Superheat

1. Determine the suction pressure with an accurate pressure gauge at the evaporator outlet.
2. From a refrigerant pressure temperature chart, determine the saturation temperature at the observed suction pressure.
3. Measure the temperature of the suction gas at the thermostatic remote bulb location.
4. Subtract the saturation temperature obtained in step No. 2 from the temperature measured in step No. 3.
5. The difference is superheat.
6. Set the superheat for 5°F - 7°F.

### Condenser Ventilation

Be sure to Supply adequate ventilation for the condenser in Self Contained units. Allow 150 square inches for units up to 1 1/2 h.p., and 200 for condenser units over 2 h.p.

## Refrigeration (Cont'd)

### T-STAT Location (Remote cases only)

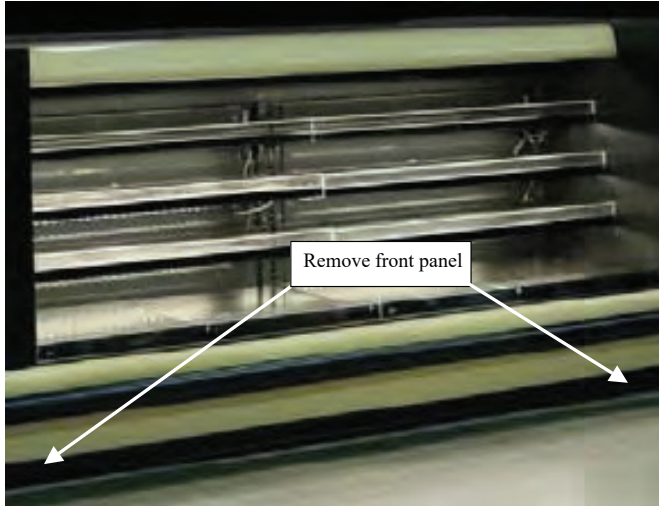

Step 1: Removal of cover: With power off remove screws and pull cover off



#### Remote

After proper testing, evacuation and charging, set the coil or evaporation temperature to 15°F by the method engineered into your system. A thermostat is located on the top of the case for temperature control. Set the thermostat to cycle in and out as per the ISLA technical data sheet.

#### Start-up

##### Self Contained (Safenet Controller)

On self contained cases the unit is completely charged and tested to the proper temperature. Remove air grill panel by lifting up and tilting out. Access electrical panel by removing 4 screws. Turn on main switch at lower right hand side of electrical box. Follow instructions for Safenet startup on page 22.

## 7. Electrical

### Wiring Color Code

<b>Standard Case Wire Color Code</b>	
<u>Color Description</u>	<u>Color</u>
■ Ground .....	Green
■ Anti-Sweat .....	Purple
■ Lights .....	Orange
■ Receptacles .....	Yellow
■ T-Stat/Solenoid 230VAC .....	Red/Black
■ T-Stat/Solenoid 115VAC .....	White/Black
■ T-Stat/Solenoid 24VAC .....	Red/White
■ Fan Motors .....	Brown
Blue Condensing Unit	

Use Copper Conductors Only  
430-01-0338 R101003

**CASE MUST BE GROUNDED**

**NOTE:** Refer to label affixed to case to determine the actual configuration as checked in the "TYPE INSTALLED" boxes.

### Electrical Circuit Identification

Standard lighting for all refrigerated models will be full length fluorescent lamps located within the case at the top.

The switch controlling the lights, the plug provided for digital scale, and the thermometer are located at the rear of the case mullion.

The receptacle that is provided on the exterior back of these models is intended for computerized scales with a five amp maximum load, not for large motors or other high wattage appliances. It should be wired to a dedicated circuit.

### Field Wiring and Serial Plate Amperage

Field Wiring must be sized for component amperes printed on the serial plate. Actual ampere draw may be less than specified. Field wiring from the refrigeration control panel to the merchandisers is required for refrigeration thermostats. Case amperes are listed on the wiring diagram, but always check the serial plate.



**DANGER**

BEFORE SERVICING  
ALWAYS DISCONNECT ELECTRICAL  
POWER AT THE MAIN DISCONNECT  
WHEN SERVICING OR REPLACING ANY  
ELECTRICAL COMPONENT.  
This includes (but not limited to) Fans, Heaters  
Thermostats, and Lights.

### Ballast Location

Ballasts are located within the access panel that runs the length of the rear of the case.





**MEDIUM TEMP MULTI-DECK ISLAND**  
**HUSSMANN - IM-04 / IMX4 - ISLA / ISLA ADVANTAGE**

REVISION DATE 08/18/23

**DOE 2017 Energy Efficiency Compliant** Hussmann refrigerated merchandisers configured for sale for use in the United States meet or surpass the requirements of the DOE 2017 energy efficiency standards.

**IM-X-04-R**  
**IM-04-R**  
 Refrigerated Self-Service Module

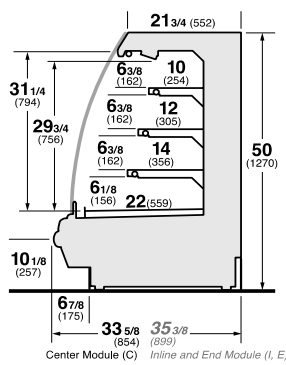

**IM-X-C4-R** Center Module | **IM-X-14-R** In-line Module  
**IM-X-C5-R** Center Module | **IM-X-15-R** In-line Module  
**IM-C5-R** Center Module | **IM-15-R** In-line Module

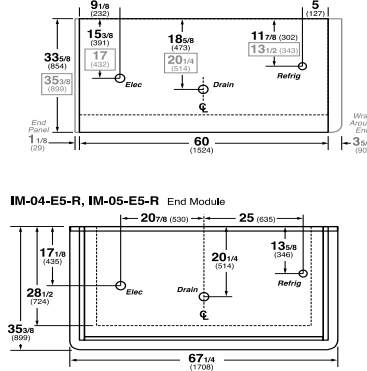

**REFRIGERATION DATA:**

CASE LENGTHS	CASE USAGE	CAPACITY *** (BTU/HR/FT)		TEMPERATURE (°F)			VELOCITY (FT/MIN)
		RATING CONDITION		EVAPORATOR		DISCHARGE AIR ** (°F)	
		NSF 7	AHRI 1200	NSF 7	AHRI 1200	NSF 7	
3', 4', 5', 6', 8', 10', 12'	DELI / DAIRY	800	800	25	25	30~35	150~250
3', 4', 5', 6', 8', 10', 12'	DELI (CO2)	830	800	24	24	28~30	150~250
3', 4', 5', 6', 8', 10', 12'	MEAT	1130	800	21	25	25~30	150~250

CASE LENGTHS	EST. REFRG. CHRGE. 404A (LBS)	GLYCOL (20°F INLET, 6° RISE)	
		GPM	PSI
3'	0.7	0.9	0.7
4'	1.0	1.2	1.4
5'	1.2	1.4	2.1
6'	1.4	1.7	1.2
8'	2.0	2.3	2.0
10'	2.5	2.8	2.9
12'	2.9	3.3	2.7

\*\*FRONT DISCHARGE AIR MEASURED INSIDE AIR CURTAIN HONEYCOMB  
 \*\*\*REFRIGERATION NOTES:

- 1) BTU/HR/FT INCLUDE 1 ROW CANOPY LED LIGHTING. ADD 10 BTUS/SHELF/FT FOR EACH SHELF (LIGHT)
- 2) MEAT CASE SPECS ARE FOR PACKAGED MEAT.
- 3) AHRI 1200 RATING POINT FOR ENERGY CONSUMPTION COMPARISON ONLY
- 4) USE DEW POINT FOR HIGH GLIDE REFRIGERANTS. CARE SHOULD BE TAKEN TO USE THE DEW POINT IN P/T TABLES FOR MEASURING AND ADJUSTING SUPERHEAT. ADJUST EVAPORATOR PRESSURE AS NEEDED TO MAINTAIN THE DISCHARGE AIR TEMPERATURE SHOWN.
- 5) RATING CONDITION IS NSF TYPE I, 75°F/55% RH
- 6) FOR DX CO2 APPLICATIONS, THE AVERAGE EVAPORATOR TEMPERATURE MAY BE LOWERED BY UP TO 2°F TO 5°F BUT NOT MORE THAN 5°F TO MAINTAIN 50PSIG PRESSURE DROP ACROSS THE EXPANSION DEVICE (EEV). AN EEPR VALVE MUST BE USED IF THE SYSTEM SUCTION PRESSURE IS MORE THAN 5 DEGREES BELOW THE PUBLISHED CASE EVAPORATOR TEMPERATURE

**REFRIGERATION DATA CONTINUED:**

ELEC. THERMOSTAT / AIR SENSOR SETTINGS			DEFROST TYPE	TIME (MIN)	DEFROST FREQUENCY (#/DAY)	TERM. TEMP (°F) COIL ONLY	DRIP TIME	DEFROST WATER (LBS/DAY/FT)
USAGE	CUT IN (°F)	CUT OUT (°F)						
DELI / DAIRY	33	30	OFF TIME	20	6	48	N/A	6.0
DELI (CO2)	30	28	OFF TIME					6.0
MEAT	31	28	OFF TIME					7.0

END PANEL WIDTH KEY		
# OF END PNLS	END PNL WIDTH	TOTAL ADDED LENGTH (IN.)
1	1.125	1.125
2	1.125	2.25

**ELECTRICAL DATA:**

**STANDARD FANS, HEATERS, LED LIGHTS (115 VOLT)**

CASE LENGTH	EVAPORATOR FANS						LED CANOPY LIGHTS		LED SHELF LIGHTS		MAX. LED LOAD (W/ ALL OPTIONS)		ANTI-SWEAT HEATERS (ON FAN CIRCUIT)		CONVENIENCE OUTLETS (OPTIONAL)		
	# OF EVAP FANS	BLADE DIA. (IN.)	BLADE PITCH (°)	AMPS	WATTS	AMPS	WATTS	AMPS	WATTS	AMPS	WATTS	AMPS	WATTS	# OUTLETS	VOLTS	AMPS	
3'	1	8	20	0.3	8	0.2	19	0.2	23	0.4	42	N/A	N/A	1	115	15	
4'	1	8	25	0.3	8	0.2	27	0.3	31	0.5	58	N/A	N/A	1	115	15	
5'	1	8	30	0.3	8	0.3	34	0.3	39	0.6	73	N/A	N/A	1	115	15	
6'	2	8	20	0.6	16	0.3	39	0.4	46	0.7	85	N/A	N/A	1	115	15	
8'	2	8	25	0.6	16	0.5	54	0.5	62	1.0	116	N/A	N/A	1	115	15	
10'	2	8	30	0.6	16	0.6	68	0.7	78	1.3	146	N/A	N/A	1	115	15	
12'	3	8	25	0.9	24	0.7	81	0.8	93	1.5	173	N/A	N/A	2	115	30	

**OPTIONAL HIGH OUTPUT LED LIGHTS (115 VOLT)**

CASE LENGTH	CANOPY LIGHTS H.O. LED		SHELF LIGHTS H.O. LED		MAX. H.O. LED LOAD	
	AMPS	WATTS	AMPS	WATTS	AMPS	WATTS
3'	0.2	24	N/A	N/A	0.2	24
4'	0.3	32	N/A	N/A	0.3	32
5'	N/A	N/A	N/A	N/A	N/A	N/A
6'	0.4	47	N/A	N/A	0.4	47
8'	0.6	64	N/A	N/A	0.6	64
10'	N/A	N/A	N/A	N/A	N/A	N/A
12'	0.8	96	N/A	N/A	0.8	96



**MEDIUM TEMP SELF-SERVICE MULTI-DECK**  
**HUSSMANN - IM-05 / IMX5 - ISLA / ISLA ADVANTAGE**

REVISION DATE 04/29/24

**IM-X-C4-R** Center Module | **IM-X-14-R** In-line Module  
**IM-X-C5-R** Center Module | **IM-X-15-R** In-line Module  
**IM-C5-R** Center Module | **IM-15-R** In-line Module



Hussmann refrigerated merchandisers configured for sale for use in the United States meet or surpass the requirements of the DOE 2017 energy efficiency standards.

**IM-X-05-R**  
**IM-05-R**

Refrigerated Self-Service Module

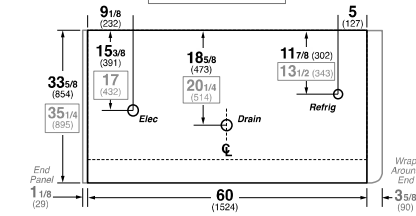
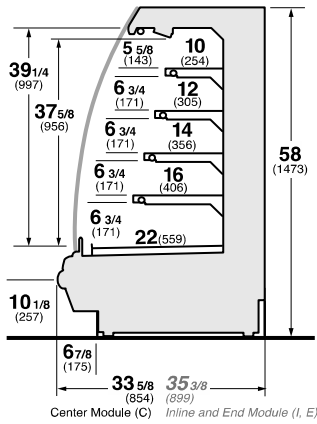

**IM-X-05-E5-R** End Module

**IM-E5-R** End Module

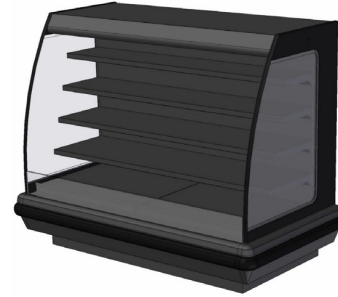
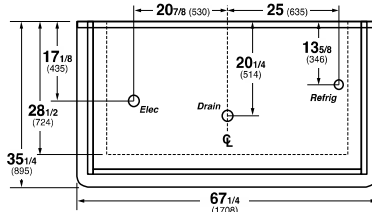

**REFRIGERATION DATA:**

CASE LENGTHS	CASE USAGE	CAPACITY *** (BTU/HR/FT)		TEMPERATURE (°F)			VELOCITY (FT/MIN)
		RATING CONDITION		EVAPORATOR		DISCHARGE AIR ** (°F)	
		NSF 7	AHRI 1200	NSF 7	AHRI 1200	NSF 7	
3',4',5',6',8',10',12'	DELI / DAIRY	1110	905	25	26	30~32	225~250
3',4',5',6',8',10',12'	DELI (CO2)	1200	905	24	24	28~30	225~250
3',4',5',6',8',10',12'	MEAT	1430	905	21	26	28~30	225~250

\*\*FRONT DISCHARGE AIR MEASURED INSIDE AIR CURTAIN HONEYCOMB

\*\*\*REFRIGERATION NOTES:

- 1) BTU'S INCLUDE CANOPY LIGHTS ONLY. ADD 10 BTUS/SHELF/FT FOR EACH SHELF (LIGHT)
- 2) MEAT CASE SPECS ARE FOR PACKAGED MEAT.
- 3) AHRI 1200 RATING POINT FOR ENERGY CONSUMPTION COMPARISON ONLY.
- 4) USE DEW POINT FOR HIGH GLIDE REFRIGERANTS. CARE SHOULD BE TAKEN TO USE THE DEW POINT IN P/T TABLES FOR MEASURING AND ADJUSTING SUPERHEAT. ADJUST EVAPORATOR PRESSURE AS NEEDED TO MAINTAIN THE DISCHARGE AIR TEMPERATURE SHOWN.
- 5) RATING CONDITION IS NSF TYPE I, 75°F/55% RH
- 6) FOR DX CO2 APPLICATIONS, THE AVERAGE EVAPORATOR TEMPERATURE MAY BE LOWERED BY UP TO 2°F TO 5°F BUT NOT MORE THAN 5°F TO MAINTAIN 50PSIG PRESSURE DROP ACROSS THE EXPANSION DEVICE (EEV). AN EEPR VALVE MUST BE USED IF THE SYSTEM SUCTION PRESSURE IS MORE THAN 5 DEGREES BELOW THE PUBLISHED CASE EVAPORATOR TEMPERATURE

CASE LENGTHS	EST. REFG. CHR.G. 404A (LBS)	20°F GLYCOL 6° RISE	
		GPM	PSI
3'	0.7	1.2	1.1
4'	1.0	1.6	2.0
5'	1.2	2.0	3.1
6'	1.4	2.4	1.8
8'	2.0	3.1	2.9
10'	2.5	3.8	4.2
12'	2.9	4.5	3.9

**REFRIGERATION DATA CONTINUED:**

ELEC. THERMOSTAT / AIR SENSOR SETTINGS			DEFROST TYPE	TIME (MIN)	DEFROST FREQUENCY (#/DAY)	TERM. TEMP (°F) COIL ONLY	DRIP TIME	DEFROST WATER (LBS/DAY/FT)
USAGE	CUT IN (°F)	CUT OUT (°F)						
DELI / DAIRY	33	30	OFF TIME	20	6	52	N/A	7.5
DELI (CO2)	30	28						7.5
MEAT	31	28						9

END PANEL WIDTH KEY		
# OF END PNLS	END PNL	TOTAL ADDED LENGTH (IN.)
1	1.125	1.125
2	1.125	2.25

**ELECTRICAL DATA:**

**STANDARD FANS, HEATERS, LED LIGHTS (115 VOLT)**

CASE LENGTH	EVAPORATOR FANS					CANOPY LIGHTS LED		LED SHELF LIGHTS		MAX. LOAD (W/ ALL)		ANTI-SWEAT HEATERS (ON FAN CIRCUIT)		CONVENIENCE OUTLETS (OPTIONAL)		
	# OF EVAP FANS	BLADE DIA. (IN.)	BLADE PITCH (°)	AMPS	WATTS	AMPS	WATTS	AMPS	WATTS	AMPS	WATTS	AMPS	WATTS	# OUTLETS	VOLTS	AMPS
3'	1	8	25	0.3	8	0.17	19	0.27	31	0.44	50	N/A	N/A	1	115	15
4'	1	8	25	0.3	8	0.23	27	0.36	41	0.59	68	N/A	N/A	1	115	15
5'	1	8	30	0.3	8	0.30	34	0.45	52	0.75	86	N/A	N/A	1	115	15
6'	2	8	25	0.6	16	0.34	39	0.54	62	0.87	100	N/A	N/A	1	115	15
8'	2	8	25	0.6	16	0.47	54	0.72	82	1.18	136	N/A	N/A	1	115	15
10'	2	8	30	0.6	16	0.59	68	0.90	104	1.49	172	N/A	N/A	1	115	15
12'	3	8	25	0.9	24	0.70	81	1.07	124	1.78	204	N/A	N/A	2	115	30

**OPTIONAL HIGH OUTPUT LED LIGHTS (115 VOLT)**

CASE LENGTH	CANOPY LIGHTS H.O. LED		SHELF LIGHTS H.O. LED		MAX. H.O. LED LOAD	
	AMPS	WATTS	AMPS	WATTS	AMPS	WATTS
3'	0.21	24	0.45	52	0.66	76
4'	0.28	32	0.53	61	0.81	93
5'	N/A	N/A	N/A	N/A	N/A	N/A
6'	0.41	47	0.90	104	1.31	151
8'	0.56	64	1.06	122	1.61	186
10'	N/A	N/A	N/A	N/A	N/A	N/A
12'	0.83	96	1.59	183	2.42	278

# Spec Sheet ((Cont'd))



**MEDIUM TEMP MULTI-DECK ISLAND**  
**HUSSMANN - IM-04-(EN or CN)-R / IMX4 (EN or CN)-R - ISLA / ISLA ADVANTAGE**

REVISION DATE 4/29/24



Hussmann refrigerated merchandisers configured for sale for use in the United States meet or surpass the requirements of the DOE 2017 energy efficiency standards.

**IM-04-NR IM-X-04-R**  
 Isla Narrow Multi-Deck Self-Service

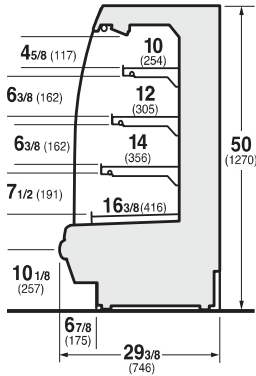

**IM-C-NR Center Module / IM-I-NR In-line Module**

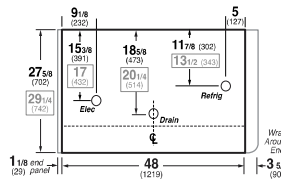

**IM-E-NR End Module**

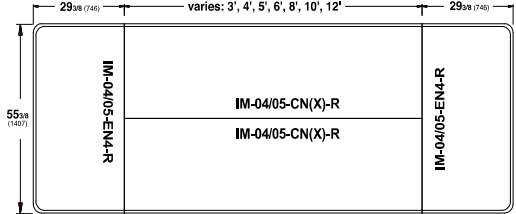
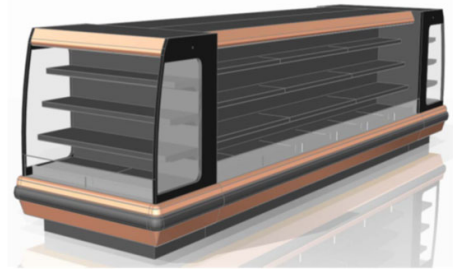
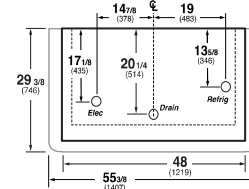

**REFRIGERATION DATA:**

CASE LENGTHS	CASE USAGE	CAPACITY *** (BTU/HR/FT)		TEMPERATURE (°F)			VELOCITY (FT/MIN)
		RATING CONDITION		EVAPORATOR		DISCHARGE AIR ** (°F)	
		NSF 7	AHRI 1200	NSF 7	AHRI 1200	NSF 7	
3', 4', 5', 6', 8', 10', 12'	DELI / DAIRY	825	800	25	26	30~32	150~250
3', 4', 5', 6', 8', 10', 12'	MEAT	1000	800	21	26	28~30	150~250

CASE LENG HS	EST. REFG. CHRG. (R404A) (LBS)	GLYCOL (20°F INLET, 6° RISE)	
		GPM	PSI
3'	0.7	0.9	0.7
4'	1.0	1.2	1.4
5'	1.2	1.4	2.1
6'	1.4	1.7	1.2
8'	2.0	2.2	2.0
10'	2.5	2.8	2.9
12'	2.9	3.3	2.7

\*\*FRONT DISCHARGE AIR MEASURED INSIDE AIR CURTAIN HONEYCOMB

\*\*\*REFRIGERATION NOTES:

- 1) BTU'S INCLUDE CANOPY LIGHTS. ADD 10 BTUS/SHELF/FT FOR EACH SHELF (LIGHT)
- 2) MEAT CASE SPECS ARE FOR PACKAGED MEAT.
- 3) AHRI 1200 RATING POINT FOR ENERGY CONSUMPTION COMPARISON ONLY.
- 4) USE DEW POINT FOR HIGH GLIDE REFRIGERANTS. CARE SHOULD BE TAKEN TO USE THE DEW POINT IN P/T TABLES FOR MEASURING AND ADJUSTING SUPERHEAT. ADJUST EVAPORATOR PRESSURE AS NEEDED TO MAINTAIN THE DISCHARGE AIR TEMPERATURE SHOW
- 5) RATING CONDITION IS NSF TYPE I, 75°F/55% RH

**REFRIGERATION DATA CONTINUED:**

ELEC. THERMOSTAT / AIR SENSOR SETTINGS		DEFROST TYPE	TIME (MIN)	DEFROST FREQUENCY (#/DAY)	TERM. TEMP (°F) COIL ONLY	DRIP TIME	DEFROST WATER (LBS/DAY/FT)	
USAGE	CUT IN (°F)							CUT OUT (°F)
DELI / DAIRY	33	30	OFF TIME	20	6	48	N/A	6.0
MEAT	31	28	OFF TIME	20	6	48	N/A	7.0

END PANEL WIDTH KEY		
# OF END PNLS	END PNL WIDTH (IN.)	TOTAL ADDED LENGTH (IN.)
1	1.125	1.125
2	1.125	2.25

**ELECTRICAL DATA:**

**STANDARD FANS, HEATERS, LED LIGHTS (115 VOLT)**

CASE LENGTH	EVAPORATOR FANS					CANOPY LIGHTS LED		OPTIONAL LED SHELF LIGHTS		MAX. LED LOAD (W/ ALL OPTIONS)		ANTI-SWEAT HEATERS (ON FAN CIRCUIT)		CONVENIENCE OUTLETS (OPTIONAL)		
	# OF EVAP FANS	BLADE DIA. (IN.)	BLADE PITCH (°)	AMPS	WATTS	AMPS	WATTS	AMPS	WATTS	AMPS	WATTS	AMPS	WATTS	# OUTLETS	VOLTS	AMPS
3'	1	8	20	0.3	8	0.2	19	0.2	23	0.4	42	N/A	N/A	N/A	N/A	N/A
4'	1	8	20	0.3	8	0.2	27	0.3	31	0.5	58	N/A	N/A	N/A	N/A	N/A
5'	1	8	25	0.3	8	0.3	34	0.3	39	0.6	73	N/A	N/A	N/A	N/A	N/A
6'	2	8	20	0.6	16	0.3	39	0.4	46	0.7	85	N/A	N/A	N/A	N/A	N/A
8'	2	8	20	0.6	16	0.5	54	0.5	62	1.0	116	N/A	N/A	N/A	N/A	N/A
10'	2	8	25	0.6	16	0.6	68	0.7	78	1.3	146	N/A	N/A	N/A	N/A	N/A
12'	3	8	20	0.9	24	0.7	81	0.8	93	1.5	173	N/A	N/A	N/A	N/A	N/A

**OPTIONAL HIGH OUTPUT LED LIGHTS (115 VOLT)**

CASE LENGTH	CANOPY LIGHTS H.O. LED		OPTIONAL H.O. SHELF		MAX. H.O. LED LOAD	
	AMPS	WATTS	AMPS	WATTS	AMPS	WATTS
3'	0.2	24	N/A	N/A	0.2	24
4'	0.3	32	N/A	N/A	0.3	32
5'	N/A	N/A	N/A	N/A	N/A	N/A
6'	0.4	47	N/A	N/A	0.4	47
8'	0.6	64	N/A	N/A	0.6	64
10'	N/A	N/A	N/A	N/A	N/A	N/A
12'	0.6	64	N/A	N/A	0.6	64

# Spec Sheet (Cont'd)

IM-04-R

**HUSSMANN** Specialty Products  
**IM-04-XN-R**



**MEDIUM TEMP MULTI-DECK ISLAND TYPE II CONDITIONS-PRELIMINARY**  
Isla - IM-04-(EN or CN)(XX)-R CASE MODULES (ISLA)(CHINO)

DOE 2012 Energy Efficiency Compliant Hussmann refrigerated merchandisers configured for sale for use in the United States meet or surpass the requirements of the DOE 2012 energy efficiency standards.

**IM-04-NR**

Isla Narrow Multi-Deck Self-Service

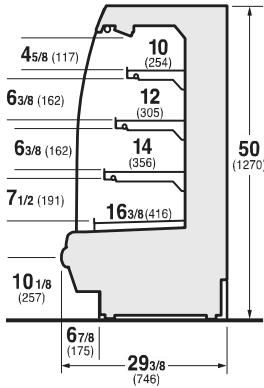

**IM-C-NR Center Module** | **IM-I-NR In-line Module**

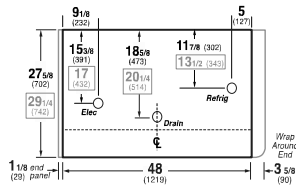

**IM-E-NR End Module**

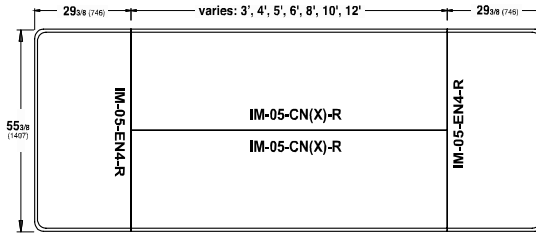
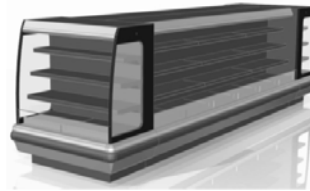
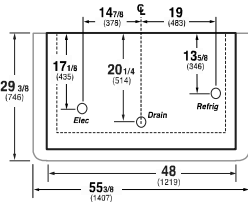

**REFRIGERATION DATA:**

MODULE LENGTH	CASE USAGE	CAPACITY *** (BTU/HR/TOTAL)		TEMPERATURE (°F)										VELOCITY		EST. REFRIG. CHR.G. (LBS)	GLYCOL REQUIREMENTS		PAR- PARALLEL CONV- CONVENTIONAL
				EVAPORATOR***					UNIT SIZING*					DISCHARGE AIR (T5 LIGHTS DELI, LED'S MEAT)			GPM	PSI	
				PAR	CONV	UNLIGHTED	T5 LIGHTED	L.E.D. LIGHTED	UNLIGHTED	T5 LIGHTED	L.E.D. LIGHTED	PAR	CONV	(FT/MIN)	(FT/MIN)				
3'	DELI/DAIRY	3600	4140	22	NA	21	20	NA	19	30	30	200-225	1.4	1.0	1.6	N/A - NOT AVAILABLE			
4'	DELI/DAIRY	4800	5520	22	NA	21	20	NA	19	30	30	200-225	1.9	1.3	2.8	TBD - TO BE DETERMINED			
5'	DELI/DAIRY	6000	6900	22	NA	21	20	NA	19	30	30	200-225	2.3	1.7	4.4	MODULE NOMENCLATURE KEY:			
6'	DELI/DAIRY	7200	8280	22	NA	21	20	NA	19	30	30	200-225	2.8	2.0	2.1	IM = ISLA MODULE			
8'	DELI/DAIRY	9600	11040	22	NA	21	20	NA	19	30	30	200-225	3.7	2.7	3.8	04 = 50" HIGH			
10'	DELI/DAIRY	12000	13800	22	NA	21	20	NA	19	30	30	200-225	4.6	3.4	5.4	E or C = END or CENTER CASE			
12'	DELI/DAIRY	14400	16560	22	NA	21	20	NA	19	30	30	200-225	5.6	4.0	4.4	(XX) = (MODULE LENGTH IN FEET)			

\*2° F less than evaporator for pressure loss in refrigerant lines

**\*\*\*REFRIGERATION DATA CONTINUED:**

ELEC. THERMOSTAT / AIR SENSOR SETTINGS				EPR SETTINGS				CONVENTIONAL COMPRESSOR SETTINGS			
R22		R404A		R407A		R22		R404A		R407A	
USAGE	CUT IN (°F)	CUT OUT (°F)	(PSIG)	(PSIG)	(PSIG)	CUT IN (PSI)	CUT OUT (PSI)	CUT IN (PSI)	CUT OUT (PSI)	CUT IN (PSI)	CUT OUT (PSI)
DELI/DAIRY	28.0	26.0	45.4	58.3	44.7	40.0	10.0	40.0	10.0	40.0	10.0

**\*\*\* REFRIGERATION NOTES:**

- 1) TEST CONDITIONS: 80°F/55% RH
- 2) SUBJECT TO CHANGE BASED ON DESIGN CHANGES
- 3) ADD 10 BTU'S PER FOOT/PER SHELF OR CANOPY FOR OPTIONAL LED LIGHTS

**\*\*\*\* REFRIGERATION NOTES CONT:**

- 4) SPECS DO NOT INCLUDE LIGHTS

**ELECTRICAL DATA:**

MODULE LENGTH	# EVAP. FANS	TOTAL STANDARD FANS		TOTAL EE FANS		T5 CANOPY LIGHTS (DELI ONLY)		L.E.D. CANOPY LIGHTS		T5 SHELF (DELI ONLY)		L.E.D. SHELF LIGHTS		T5 TOTAL LIGHTS (DELI ONLY)		L.E.D. TOTAL LIGHTS		ANTI-SWEAT HEATERS GLASS HEATERS		AIR SWEEP HEATER		
		AMPS	WATTS	AMPS	WATTS	AMPS	WATTS	AMPS	WATTS	# ROWS	AMPS	WATTS	AMPS	WATTS	AMPS	WATTS	AMPS	WATTS	AMPS	WATTS		
		3'	1	N/A	N/A	0.30	18.0	N/A	N/A	0.08	9.0	3	N/A	N/A	0.24	27.0	N/A	N/A	0.32	36.0	N/A	N/A
4'	1	N/A	N/A	0.30	18.0	N/A	N/A	0.11	12.0	3	N/A	N/A	0.33	36.0	N/A	N/A	0.44	48.0	N/A	N/A	N/A	N/A
5'	1	N/A	N/A	0.30	18.0	N/A	N/A	0.14	15.0	3	N/A	N/A	0.42	45.0	N/A	N/A	0.56	60.0	N/A	N/A	N/A	N/A
6'	2	N/A	N/A	0.60	36.0	N/A	N/A	0.17	18.0	3	N/A	N/A	0.51	54.0	N/A	N/A	0.68	72.0	N/A	N/A	N/A	N/A
8'	2	N/A	N/A	0.60	36.0	N/A	N/A	0.22	24.0	3	N/A	N/A	0.66	72.0	N/A	N/A	0.88	96.0	N/A	N/A	N/A	N/A
10'	2	N/A	N/A	0.60	36.0	N/A	N/A	0.28	30.0	3	N/A	N/A	0.84	90.0	N/A	N/A	1.12	120.0	N/A	N/A	N/A	N/A
12'	3	N/A	N/A	0.90	54.0	N/A	N/A	0.33	36.0	3	N/A	N/A	0.99	108.0	N/A	N/A	1.32	144.0	N/A	N/A	N/A	N/A

**ELECTRICAL DATA CONTINUED:**

MODULE LENGTH	CONDENSING UNIT 208V 1 PHASE		CONVENIENCE OUTLETS		
	AMPS	WATTS	#OUTLETS	VOLTS	AMPS
3'	N/A	N/A	N/A	N/A	N/A
4'	N/A	N/A	N/A	N/A	N/A
5'	N/A	N/A	N/A	N/A	N/A
6'	N/A	N/A	N/A	N/A	N/A
8'	N/A	N/A	N/A	N/A	N/A
10'	N/A	N/A	N/A	N/A	N/A
12'	N/A	N/A	N/A	N/A	N/A

**DEFROST DATA:**

MODULE LENGTH	DEFROST TYPE	TIME (MIN.)	TERM. TEMP (°F) COIL ONLY	DRIP TIME (MIN.)	DEFROST DAY PER	ELECTRICAL DEFROST 208V 1 PHASE		DEFROST WATER (LB/DAY)
						AMPS	WATTS	
3'	OFF TIME	20	48	N/A	6	N/A	N/A	39
4'	OFF TIME	20	48	N/A	6	N/A	N/A	52
5'	OFF TIME	20	48	N/A	6	N/A	N/A	65
6'	OFF TIME	20	48	N/A	6	N/A	N/A	78
8'	OFF TIME	20	48	N/A	6	N/A	N/A	104
10'	OFF TIME	20	48	N/A	6	N/A	N/A	130
12'	OFF TIME	20	48	N/A	6	N/A	N/A	156

**OPTIONS/NOTES:**

- Single point mechanical connections
- TX valves
- Liquid Hand Valves
- Standard Shelves: Upper Shelf 12"; Bottom Shelf 16"

- Standard 50" height
- Black bumper and black interior
- PTM

# Spec Sheet (Cont'd)

## HUSSMANN Specialty Products IM-05-XN-R

IM-05-R



DOE 2012 Energy Efficiency Compliance  
Husmann refrigerated merchandisers configured for sale for use in the United States meet or surpass the requirements of the DOE 2012 energy efficiency standards.

### IM-05-NR Isla Narrow Multi-Deck Self-Service

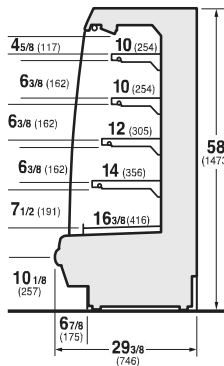

### IM-C-NR Center Module | IM-I-NR In-line Module

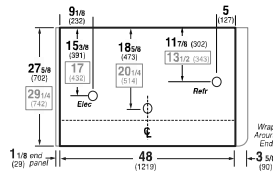

### IM-E-NR End Module

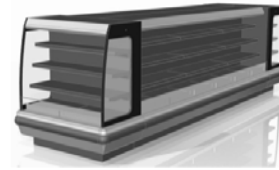
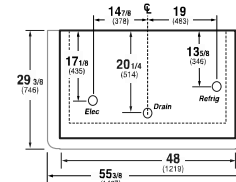

### REFRIGERATION DATA:

MODULE LENGTH	CASE USAGE	CAPACITY *** (BTU/HR/TOTAL)		TEMPERATURE (°F)										EST. REFRG. CHR.G. (LBS)	GLYCOL REQUIREMENTS		PAR- PARALLEL CONV- CONVENTIONAL		
		PAR	CONV	EVAPORATOR***					UNIT SIZING*						DISCHARGE AIR (TS LIGHTS DELI, LED'S MEAT)	VELOCITY (FT/MIN)		GPM	PSI
				UNLIGHTED	TS LIGHTED	L.E.D. LIGHTED	UNLIGHTED	TS LIGHTED	L.E.D. LIGHTED	PAR	CONV								
3'	DELI/DAIRY	3390	3899	26	NA	25	24	NA	23	32	32	200-250	1.4	1.0	1.6			N/A - NOT AVAILABLE	
3'	MEAT	3900	4485	22	NA	21	20	NA	19	28	28	200-250	1.4	1.2	2.0			TBD - TO BE DETERMINED	
4'	DELI/DAIRY	4520	5198	26	NA	25	24	NA	23	32	32	200-250	1.9	1.3	2.8			MODULE NOMENCLATURE KEY:	
4'	MEAT	5200	5980	22	NA	21	20	NA	19	28	28	200-250	1.9	1.6	3.6			IM = ISLA MODULE	
5'	DELI/DAIRY	5650	6498	26	NA	25	24	NA	23	32	32	200-250	2.3	1.7	4.4			O4 = 50" HIGH	
5'	MEAT	6500	7475	22	NA	21	20	NA	19	28	28	200-250	2.3	1.9	5.6			E or C = END or CENTER CASE	
6'	DELI/DAIRY	6780	7797	26	NA	25	24	NA	23	32	32	200-250	2.8	2.0	2.1			(XX) = (MODULE LENGTH IN FEET)	
6'	MEAT	7800	8970	22	NA	21	20	NA	19	28	28	200-250	2.8	2.3	2.7			R = REFRIGERATED SELF SERVICE MULTIDECK	
8'	DELI/DAIRY	9040	10396	26	NA	25	24	NA	23	32	32	200-250	3.7	2.7	3.6			EXAMPLE MODULE, 50" HIGH, END 5' WIDE, REFRIGERATED SELF SERVICE MULTIDECK	
8'	MEAT	10400	11960	22	NA	21	20	NA	19	28	28	200-250	3.7	3.1	4.5				
10'	DELI/DAIRY	11300	12995	26	NA	25	24	NA	23	32	32	200-250	4.6	3.4	5.4				
10'	MEAT	13000	14950	22	NA	21	20	NA	19	28	28	200-250	4.6	3.9	6.8				
12'	DELI/DAIRY	13560	15594	26	NA	25	24	NA	23	32	32	200-250	5.6	4.0	4.4				
12'	MEAT	15600	17940	22	NA	21	20	NA	19	28	28	200-250	5.6	4.7	5.5				

\*2" F less than evaporator for pressure loss in refrigerant lines

### \*\*\*\* REFRIGERATION DATA CONTINUED:

USAGE	ELEC. THERMOSTAT / AIR SENSOR SETTINGS		EPR SETTINGS			CONVENTIONAL COMPRESSOR SETTINGS					
	CUT IN (°F)	CUT OUT (°F)	R22 (PSIG)	R404A (PSIG)	R407A (PSIG)	R22		R404A		R407A	
						CUT IN (PSI)	CUT OUT (PSI)	CUT IN (PSI)	CUT OUT (PSI)	CUT IN (PSI)	CUT OUT (PSI)
DELI/DAIRY	32.0	30.0	50.0	63.9	49.0	40.0	10.0	40.0	10.0	40.0	10.0
MEAT	28.0	26.0	45.4	58.3	44.7	40.0	10.0	40.0	10.0	40.0	10.0

### \*\*\* REFRIGERATION NOTES:

- 1) TEST CONDITIONS: 75°F/55% RH
- 2) SUBJECT TO CHANGE BASED ON DESIGN CHANGES
- 3) ADD 10 BTU'S PER FOOT/PER SHELF OR CANOPY FOR OPTIONAL LED LIGHTS
- 4) MEAT CASE SPECS ARE FOR PACKAGED MEAT

### \*\*\*\* REFRIGERATION NOTES CONT:

- 5) SPECS DO NOT INCLUDE LIGHTS

### ELECTRICAL DATA:

MODULE LENGTH	# EVAP. FANS	STANDARD FANS AND HEATERS (120 VOLT)				LIGHTING: 120V INPUT VOLTAGE												ANTI-SWEAT HEATERS (On Fan Circuit)				
		TOTAL STANDARD FANS		TOTAL EEE FANS		TS CANOPY LIGHTS (DELI ONLY)		L.E.D. CANOPY LIGHTS		# ROWS	TS SHELF (DELI ONLY)		L.E.D. SHELF LIGHTS		TS TOTAL LIGHTS (DELI ONLY)		L.E.D. TOTAL LIGHTS		GLASS		AIR SWEEP	
		AMPS	WATTS	AMPS	WATTS	AMPS	WATTS	AMPS	WATTS		AMPS	WATTS	AMPS	WATTS	AMPS	WATTS	AMPS	WATTS	AMPS	WATTS	AMPS	WATTS
3'	1	N/A	N/A	0.30	18.0	N/A	N/A	0.08	9.0	4	N/A	N/A	0.33	36.0	N/A	N/A	0.42	45.0	N/A	N/A	N/A	N/A
4'	1	N/A	N/A	0.30	18.0	N/A	N/A	0.11	12.0	4	N/A	N/A	0.44	48.0	N/A	N/A	0.56	60.0	N/A	N/A	N/A	N/A
5'	1	N/A	N/A	0.30	18.0	N/A	N/A	0.14	15.0	4	N/A	N/A	0.56	60.0	N/A	N/A	0.69	75.0	N/A	N/A	N/A	N/A
6'	2	N/A	N/A	0.60	36.0	N/A	N/A	0.17	18.0	4	N/A	N/A	0.66	72.0	N/A	N/A	0.83	90.0	N/A	N/A	N/A	N/A
8'	2	N/A	N/A	0.60	36.0	N/A	N/A	0.22	24.0	4	N/A	N/A	0.89	96.0	N/A	N/A	1.11	120.0	N/A	N/A	N/A	N/A
10'	2	N/A	N/A	0.60	36.0	N/A	N/A	0.28	30.0	4	N/A	N/A	1.10	120.0	N/A	N/A	1.39	150.0	N/A	N/A	N/A	N/A
12'	3	N/A	N/A	0.90	54.0	N/A	N/A	0.33	36.0	4	N/A	N/A	1.33	144.0	N/A	N/A	1.67	180.0	N/A	N/A	N/A	N/A

### ELECTRICAL DATA CONTINUED:

MODULE LENGTH	CONDENSING UNIT 208V 1 PHASE		CONVENIENCE OUTLETS		
	AMPS	WATTS	#OUTLETS	VOLTS	AMPS
3'	N/A	N/A	N/A	N/A	N/A
4'	N/A	N/A	N/A	N/A	N/A
5'	N/A	N/A	N/A	N/A	N/A
6'	N/A	N/A	N/A	N/A	N/A
8'	N/A	N/A	N/A	N/A	N/A
10'	N/A	N/A	N/A	N/A	N/A
12'	N/A	N/A	N/A	N/A	N/A

### DEFROST DATA:

MODULE LENGTH	DEFROST TYPE	TIME (MIN.)	TERM. TEMP (°F) COIL ONLY	DRIP TIME (MIN.)	DEFROST DAY PER	ELECTRICAL DEFROST 208V 1 PHASE		DEFROST WATER (LB/DAY)
						AMPS	WATTS	
3'	OFF TIME	20	48	N/A	6	N/A	N/A	30
4'	OFF TIME	20	48	N/A	6	N/A	N/A	40
5'	OFF TIME	20	48	N/A	6	N/A	N/A	50
6'	OFF TIME	20	48	N/A	6	N/A	N/A	60
8'	OFF TIME	20	48	N/A	6	N/A	N/A	80
10'	OFF TIME	20	48	N/A	6	N/A	N/A	100
12'	OFF TIME	20	48	N/A	6	N/A	N/A	120

### OPTIONS/NOTES:

- Single point mechanical connections
- TX valves
- Liquid Hand Valves
- Standard Shelves: Upper Shelf 12"; Bottom Shelf 16"

- Standard 50" height
- Black bumper and black interior
- PTM

# Spec Sheet (Cont'd)

**HUSSMANN** Specialty Products  
IM-05-XN-R

IM-05-R



**MEDIUM TEMP MULTI-DECK ISLAND TYPE II CONDITIONS**  
IsLa - IM-05-(EN or CN)(XX)-R CASE MODULES [ISLA](CHINO)

DOE 2012 Energy Efficiency Compliant Hussmann refrigerated merchandisers configured for sale for use in the United States meet or surpass the requirements of the DOE 2012 energy efficiency standards.

**IM-05-NR**  
IsLa Narrow Multi-Deck Self-Service

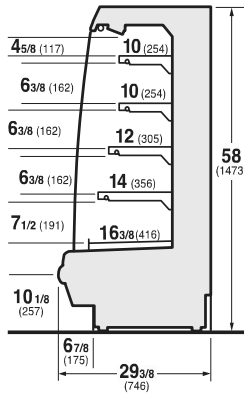

**IM-C-NR** Center Module / **IM-I-NR** In-line Module

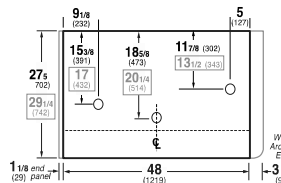

**IM-E-NR** End Module

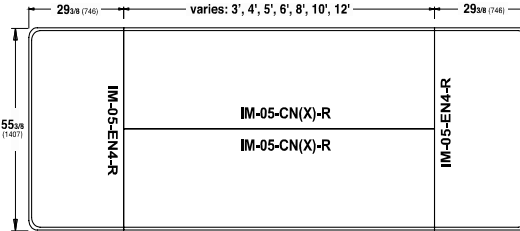
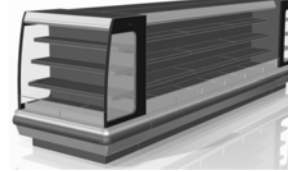
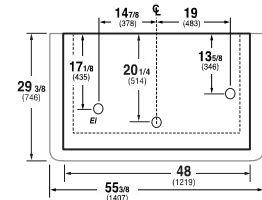

**REFRIGERATION DATA:**

MODULE LENGTH	CASE USAGE	CAPACITY *** (BTU/HR/TOTAL)		TEMPERATURE (°F)									VELOCITY		EST. REFRIG. CHR.G. (LBS)		GLYCOL REQUIREMENTS		PAR- PARALLEL CONV- CONVENTIONAL
		PAR	CONV	EVAPORATOR***			UNIT SIZING*			DISCHARGE AIR (T5 LIGHTS DELI, LED'S MEAT)			GPM	PSI	N/A - NOT AVAILABLE TBD - TO BE DETERMINED				
				UNLIGHTED	T5 LIGHTED	L.E.D. LIGHTED	UNLIGHTED	T5 LIGHTED	L.E.D. LIGHTED	PAR	CONV	(FT/MIN)							
3'	DELI/DAIRY	5070	5831	22	NA	21	20	NA	19	30	30	200-250	1.4	1.0	1.6				
4'	DELI/DAIRY	6760	7774	22	NA	21	20	NA	19	30	30	200-250	1.9	1.3	2.8				
5'	DELI/DAIRY	8450	9718	22	NA	21	20	NA	19	30	30	200-250	2.3	1.7	4.4				
6'	DELI/DAIRY	10140	11661	22	NA	21	20	NA	19	30	30	200-250	2.8	2.0	2.1				
8'	DELI/DAIRY	13520	15548	22	NA	21	20	NA	19	30	30	200-250	3.7	2.7	3.6				
10'	DELI/DAIRY	16900	19435	22	NA	21	20	NA	19	30	30	200-250	4.6	3.4	5.4				
12'	DELI/DAIRY	20280	23322	22	NA	21	20	NA	19	30	30	200-250	5.6	4.0	4.4				

\*2° F less than evaporator for pressure loss in refrigerant lines

**REFRIGERATION DATA CONTINUED:**

USAGE	ELEC. THERMOSTAT / AIR SENSOR SETTINGS		EPR SETTINGS			CONVENTIONAL COMPRESSOR SETTINGS					
	CUT IN (°F)	CUT OUT (°F)	R22 (PSIG)	R404A (PSIG)	R407A (PSIG)	R22		R404A		R407A	
						CUT IN (PSI)	CUT OUT (PSI)	CUT IN (PSI)	CUT OUT (PSI)	CUT IN (PSI)	CUT OUT (PSI)
DELI/DAIRY	28.0	26.0	45.4	58.3	44.7	40.0	10.0	40.0	10.0	40.0	10.0

**REFRIGERATION NOTES:**

- 1) TEST CONDITIONS: 80°F/55% RH
- 2) SUBJECT TO CHANGE BASED ON DESIGN CHANGES
- 3) ADD 10 BTU'S PER FOOT/PER SHELF OR CANOPY FOR OPTIONAL LED LIGHTS

**REFRIGERATION NOTES CONT:**

- 4) SPECS DO NOT INCLUDE LIGHTS

**ELECTRICAL DATA:**

LIGHTING: 120V INPUT VOLTAGE

MODULE LENGTH	STANDARD FANS AND HEATERS (120 VOLT)																																					
	# EVAP. FANS		TOTAL STANDARD FANS				TOTAL EE FANS				T5 CANOPY LIGHTS (DELI ONLY)				L.E.D. CANOPY LIGHTS				T5 SHELF LIGHTS (DELI ONLY)				L.E.D. SHELF LIGHTS				T5 TOTAL LIGHTS (DELI ONLY)				L.E.D. TOTAL LIGHTS				ANTI-SWEAT HEATERS GLASS HEATERS		AIR SWEEP HEATER	
	AMPS	WATTS	AMPS	WATTS	AMPS	WATTS	AMPS	WATTS	AMPS	WATTS	AMPS	WATTS	AMPS	WATTS	AMPS	WATTS	AMPS	WATTS	AMPS	WATTS	AMPS	WATTS	AMPS	WATTS	AMPS	WATTS	AMPS	WATTS	AMPS	WATTS								
3'	1	N/A	N/A	0.30	18.0	N/A	N/A	0.08	9.0	4	N/A	N/A	0.33	36.0	N/A	N/A	0.42	45.0	N/A	N/A	N/A	N/A	N/A	N/A	N/A	N/A	N/A	N/A	N/A	N/A	N/A	N/A						
4'	1	N/A	N/A	0.30	18.0	N/A	N/A	0.11	12.0	4	N/A	N/A	0.44	48.0	N/A	N/A	0.56	60.0	N/A	N/A	N/A	N/A	N/A	N/A	N/A	N/A	N/A	N/A	N/A	N/A	N/A	N/A	N/A					
5'	1	N/A	N/A	0.30	18.0	N/A	N/A	0.14	15.0	4	N/A	N/A	0.56	60.0	N/A	N/A	0.69	75.0	N/A	N/A	N/A	N/A	N/A	N/A	N/A	N/A	N/A	N/A	N/A	N/A	N/A	N/A	N/A					
6'	2	N/A	N/A	0.60	36.0	N/A	N/A	0.17	18.0	4	N/A	N/A	0.66	72.0	N/A	N/A	0.83	90.0	N/A	N/A	N/A	N/A	N/A	N/A	N/A	N/A	N/A	N/A	N/A	N/A	N/A	N/A	N/A	N/A				
8'	2	N/A	N/A	0.60	36.0	N/A	N/A	0.22	24.0	4	N/A	N/A	0.89	96.0	N/A	N/A	1.11	120.0	N/A	N/A	N/A	N/A	N/A	N/A	N/A	N/A	N/A	N/A	N/A	N/A	N/A	N/A	N/A	N/A				
10'	2	N/A	N/A	0.60	36.0	N/A	N/A	0.28	30.0	4	N/A	N/A	1.10	120.0	N/A	N/A	1.39	150.0	N/A	N/A	N/A	N/A	N/A	N/A	N/A	N/A	N/A	N/A	N/A	N/A	N/A	N/A	N/A	N/A				
12'	3	N/A	N/A	0.90	54.0	N/A	N/A	0.33	36.0	4	N/A	N/A	1.33	144.0	N/A	N/A	1.67	180.0	N/A	N/A	N/A	N/A	N/A	N/A	N/A	N/A	N/A	N/A	N/A	N/A	N/A	N/A	N/A	N/A				

**ELECTRICAL DATA CONTINUED:**

MODULE LENGTH	CONDENSING UNIT 208V 1 PHASE				CONVENIENCE OUTLETS			
	AMPS	WATTS	#OUTLETS	VOLTS	AMPS	WATTS	VOLTS	AMPS
3'	N/A	N/A	N/A	N/A	N/A	N/A	N/A	N/A
4'	N/A	N/A	N/A	N/A	N/A	N/A	N/A	N/A
5'	N/A	N/A	N/A	N/A	N/A	N/A	N/A	N/A
6'	N/A	N/A	N/A	N/A	N/A	N/A	N/A	N/A
8'	N/A	N/A	N/A	N/A	N/A	N/A	N/A	N/A
10'	N/A	N/A	N/A	N/A	N/A	N/A	N/A	N/A
12'	N/A	N/A	N/A	N/A	N/A	N/A	N/A	N/A

**DEFROST DATA:**

MODULE LENGTH	DEFROST TYPE	TIME (MIN.)	TERM. TEMP (°F) COIL ONLY	DRIP TIME (MIN.)	DEFROST DAY	ELECTRICAL DEFROST 208V 1 PHASE		DEFROST WATER (LB/DAY)
						AMPS	WATTS	
3'	OFF TIME	20	52	N/A	6	N/A	N/A	39
4'	OFF TIME	20	52	N/A	6	N/A	N/A	52
5'	OFF TIME	20	52	N/A	6	N/A	N/A	65
6'	OFF TIME	20	52	N/A	6	N/A	N/A	78
8'	OFF TIME	20	52	N/A	6	N/A	N/A	104
10'	OFF TIME	20	52	N/A	6	N/A	N/A	130
12'	OFF TIME	20	52	N/A	6	N/A	N/A	156

**OPTIONS/NOTES:**

- Single point mechanical connections
- TX valves
- Liquid Hand Valves
- Standard Shelves: Upper Shelf 12"; Bottom Shelf 16"

- Standard 50" height
- Black bumper and black interior
- PTM

## 8. Electrical Wiring Diagrams

MODEL	DESCRIPTION	SIZE	DIAGRAM
<b>IM-04-R W/LED LIGHTS</b>	IM-04-C3-R, IM-04-I3-R	3'	1H66271
	IM-04-C4-R, IM-04-I4-R	4'	1H66272
	IM-04-C5-R, IM-04-I5-R, IM-04-E5-R	5'	1H66273
	IM-04-C6-R, IM-04-I6-R	6'	1H66274
	IM-04-C8-R, IM-04-I8-R	8'	1H66275
	IM-04-C10-R, IM-04-I10-R	10'	1H66276
	IM-04-C12-R, IM-04-I12-R	12'	1H66277
<b>IM-04-R W/T-5 LIGHTS</b>	IM-04-C3-R, IM-04-I3-R	3'	1H66307
	IM-04-C4-R, IM-04-I4-R	4'	1H66308
	IM-04-C5-R, IM-04-I5-R, IM-04-E5-R	5'	1H19654
	IM-04-C6-R, IM-04-I6-R	6'	1H66309
	IM-04-C8-R, IM-04-I8-R	8'	1H21900
	IM-04-C10-R, IM-04-I10-R	10'	1H66310
	IM-04-C12-R, IM-04-I12-R	12'	1H19655
<b>IM-05-R W/LED LIGHTS</b>	IM-05-C3-R, IM-05-I3-R	3'	1H66280
	IM-05-C4-R, IM-05-I4-R	4'	1H66281
	IM-05-C5-R, IM-05-I5-R, IM-05-E5-R	5'	1H28911
	IM-05-C6-R, IM-05-I6-R	6'	1H28913
	IM-05-C8-R, IM-05-I8-R	8'	1H28912
	IM-05-C10-R, IM-05-I10-R	10'	1H66282
	IM-05-C12-R, IM-05-I12-R	12'	1H29875
<b>IM-05-R W/T-5 LIGHTS</b>	IM-05-C3-R, IM-05-I3-R	3'	1H66311
	IM-05-C4-R, IM-05-I4-R	4'	1H66312
	IM-05-C5-R, IM-05-I5-R, IM-05-E5-R	5'	1H66313
	IM-05-C6-R, IM-05-I6-R	6'	1H66314
	IM-05-C8-R, IM-05-I8-R	8'	1H66315
	IM-05-C10-R, IM-05-I10-R	10'	1H66316
	IM-05-C12-R, IM-05-I12-R	12'	1H66317

# 9. Wiring Diagrams

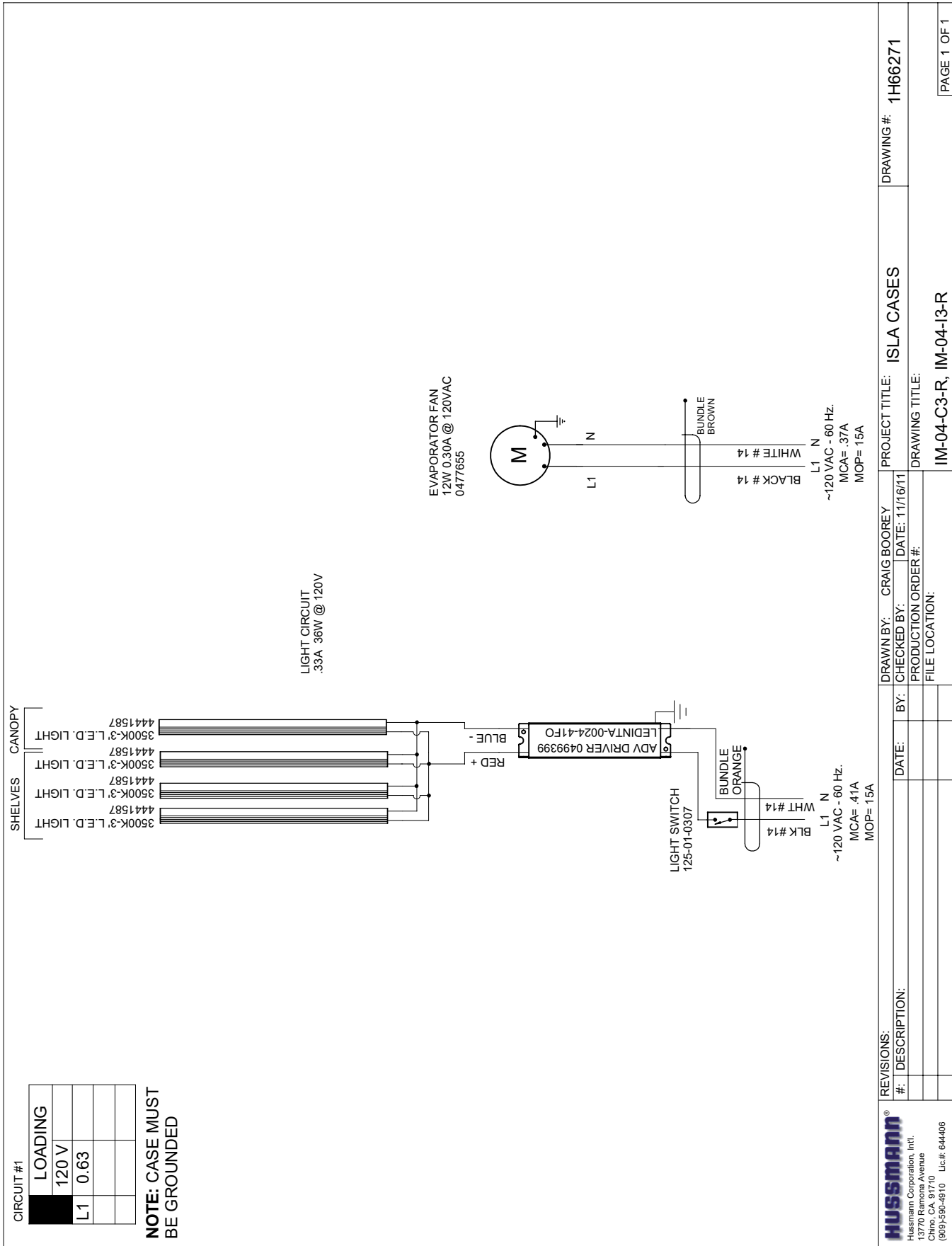



# Wiring Diagrams (Cont'd)

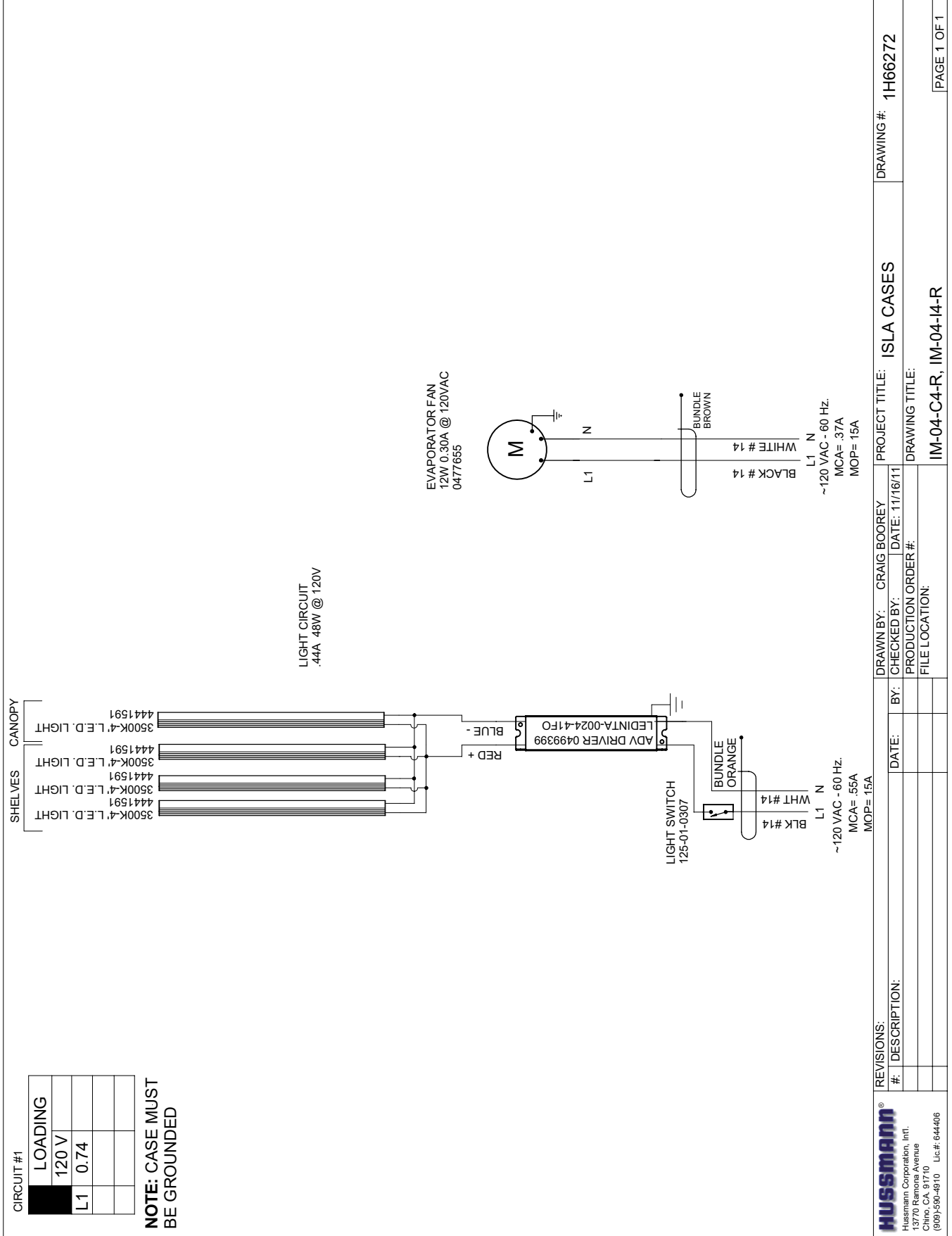

# Wiring Diagrams (Cont'd)

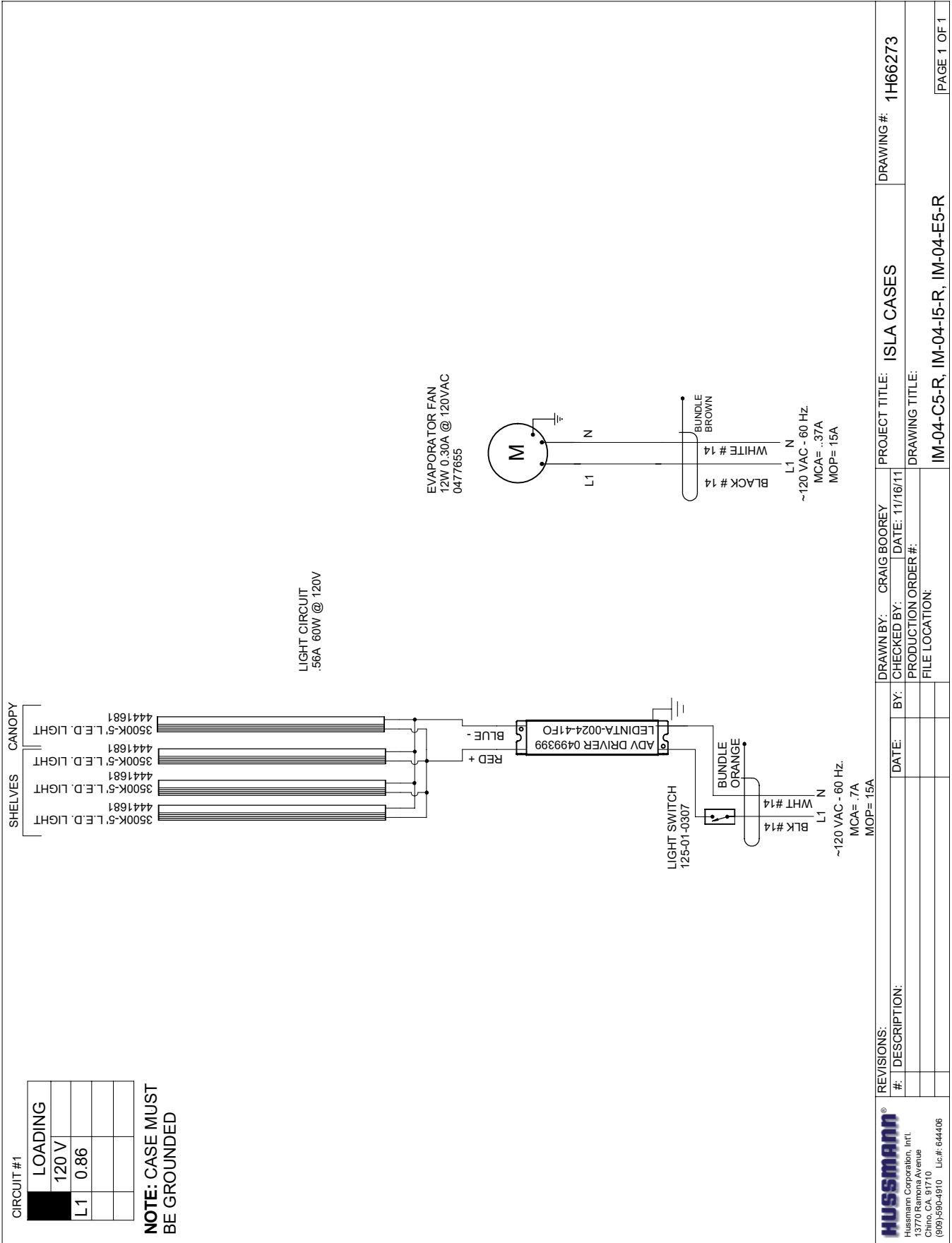

# Wiring Diagrams (Cont'd)

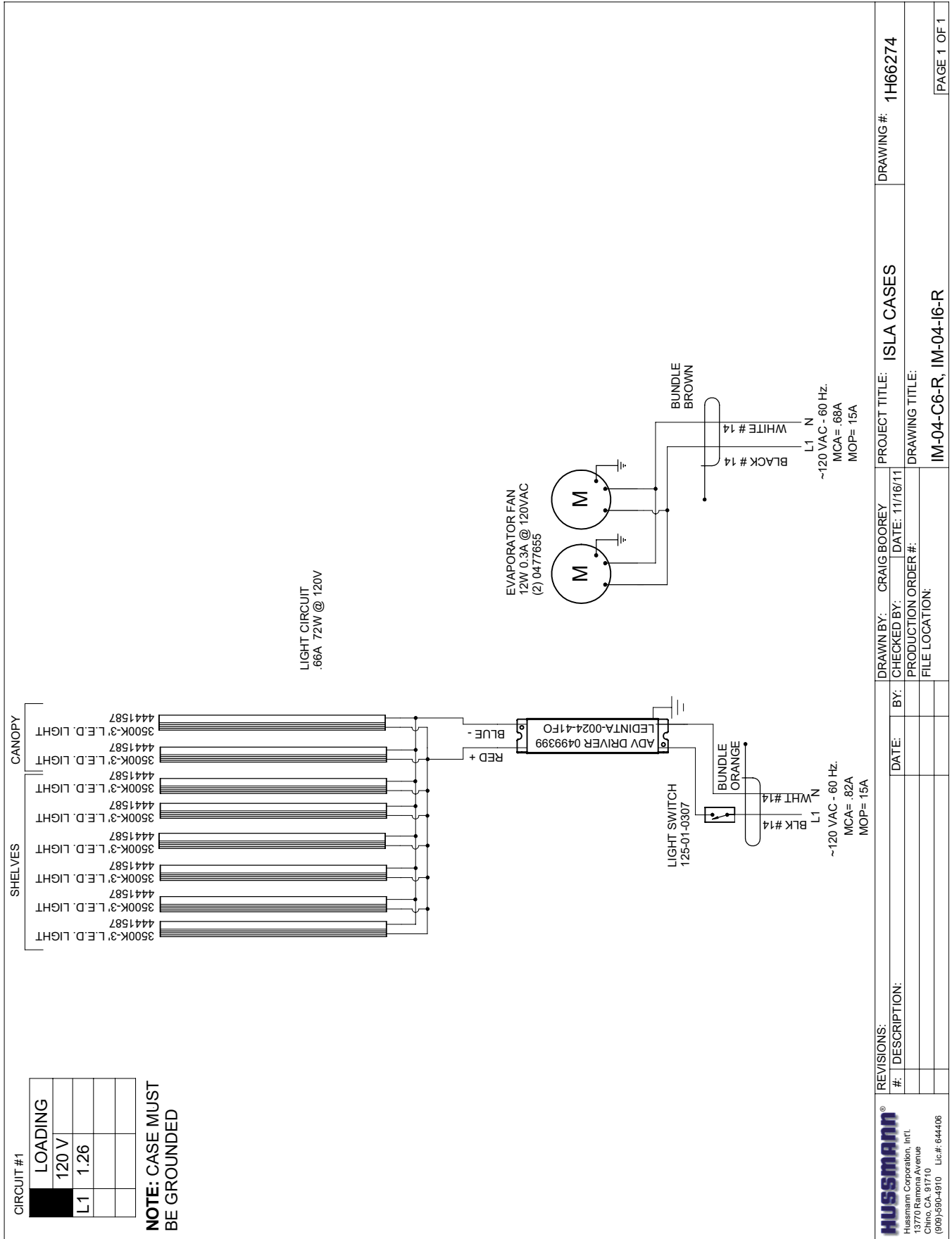

# Wiring Diagrams (Cont'd)

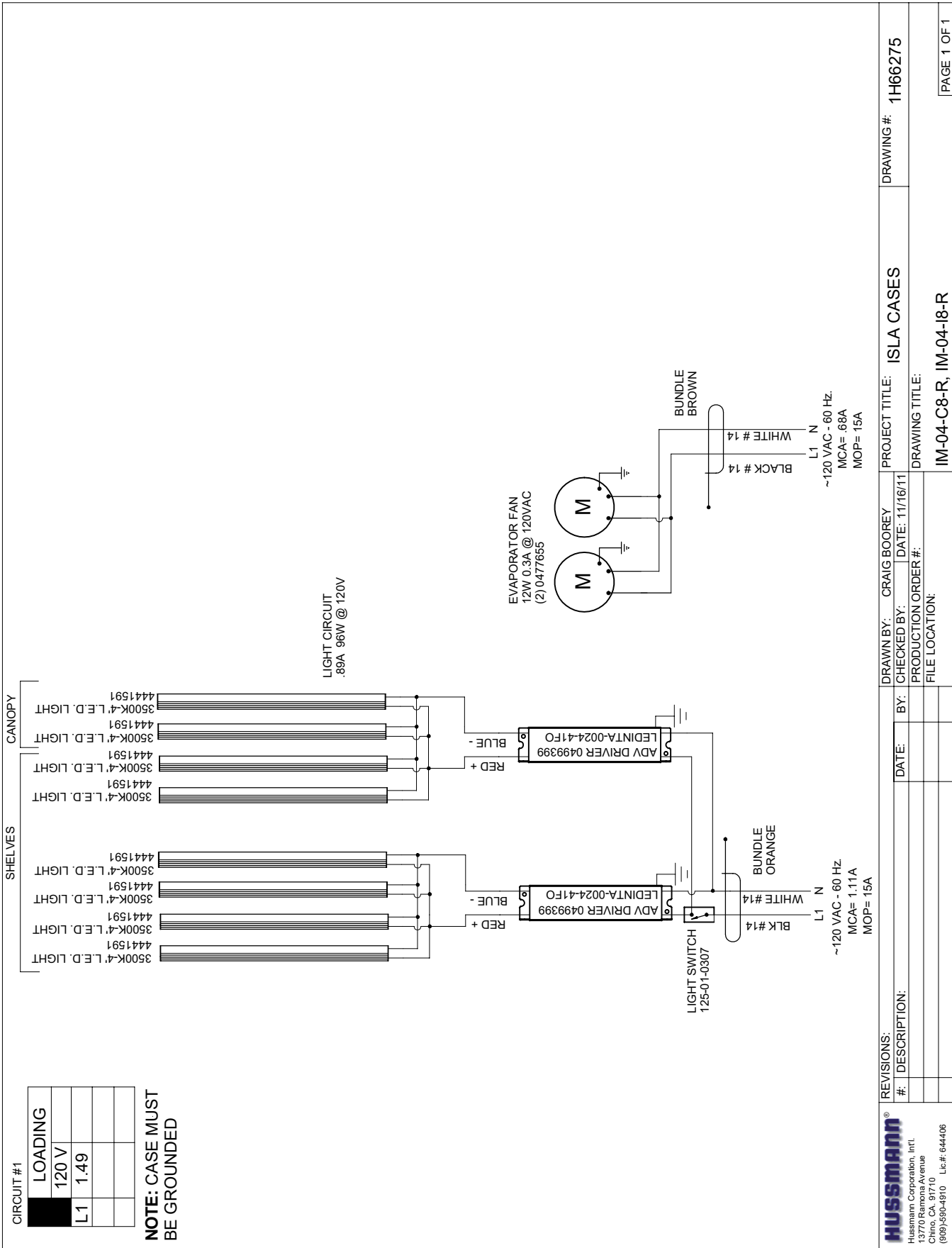

# Wiring Diagrams (Cont'd)

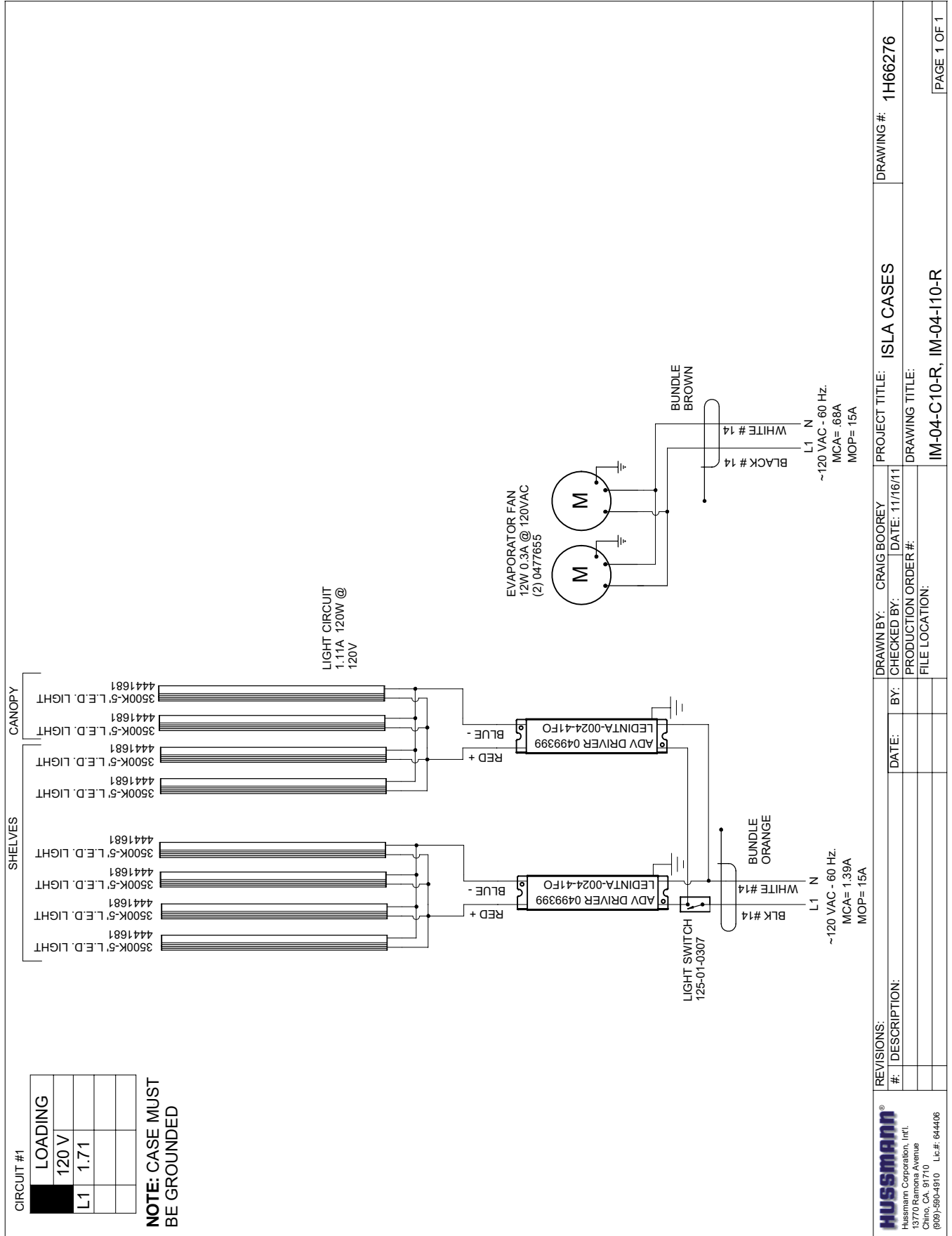

# Wiring Diagrams (Cont'd)

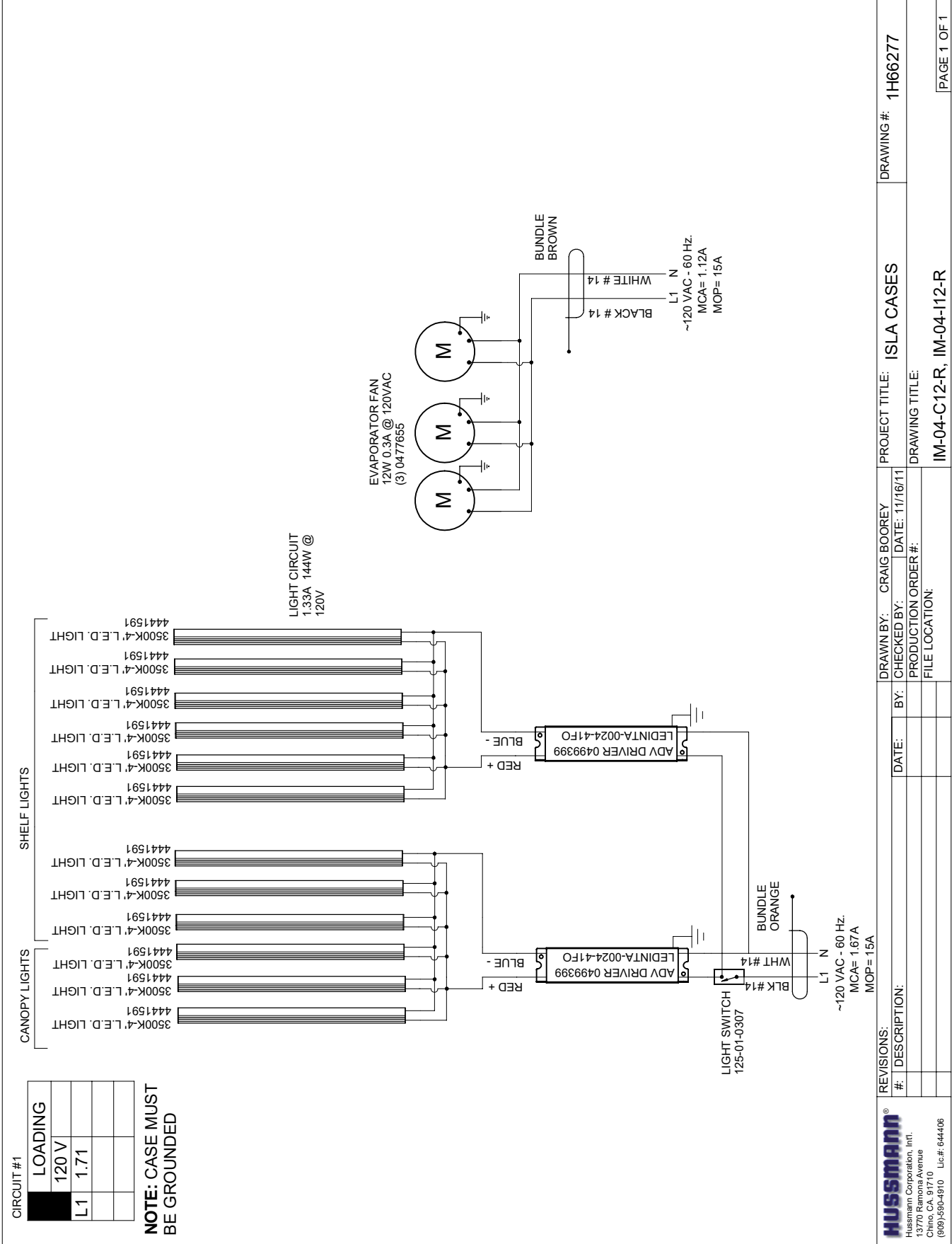

# Wiring Diagrams (Cont'd)

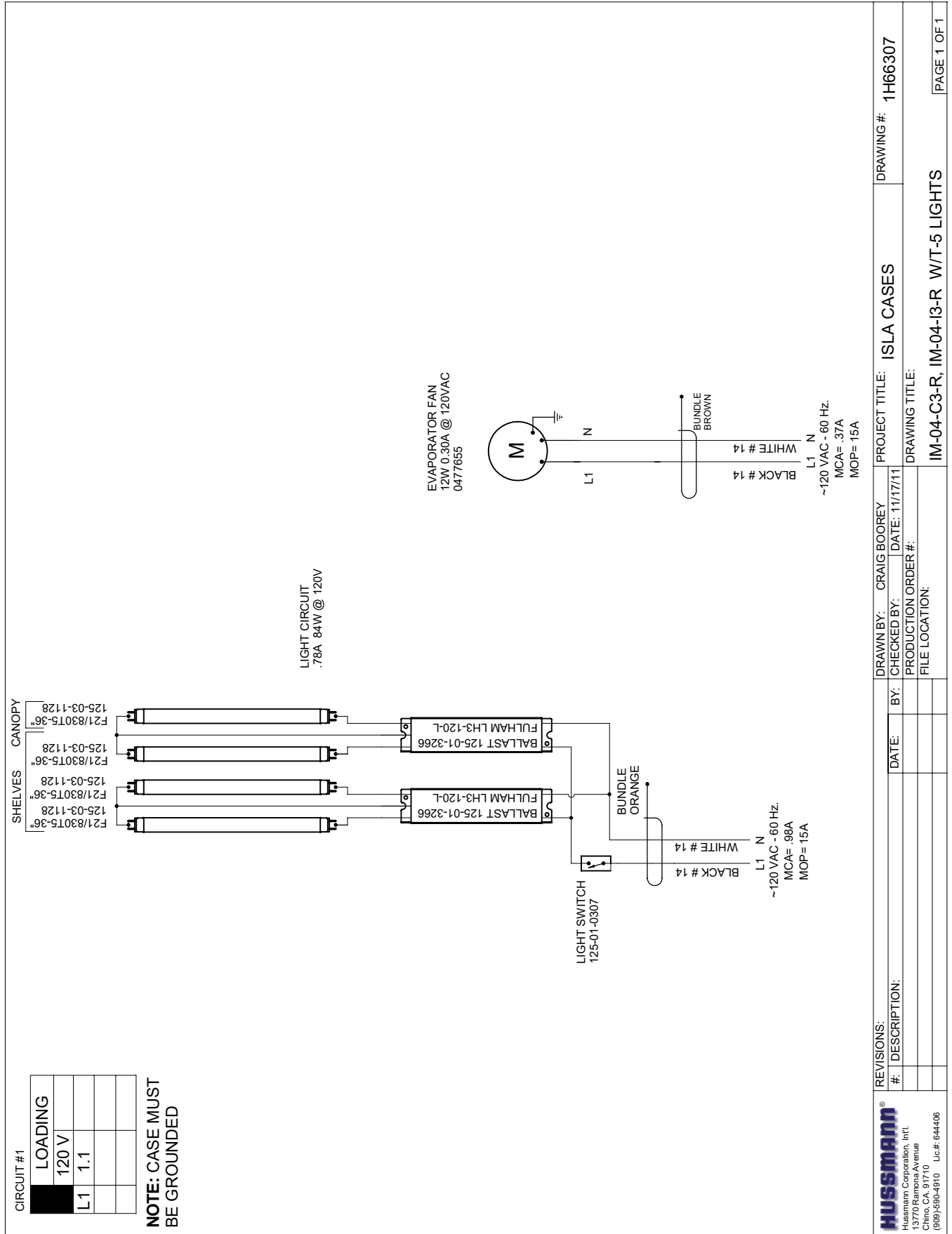

# Wiring Diagrams (Cont'd)

CIRCUIT #1	LOADING
	120 V
L1	1.2

**NOTE: CASE MUST BE GROUNDED**

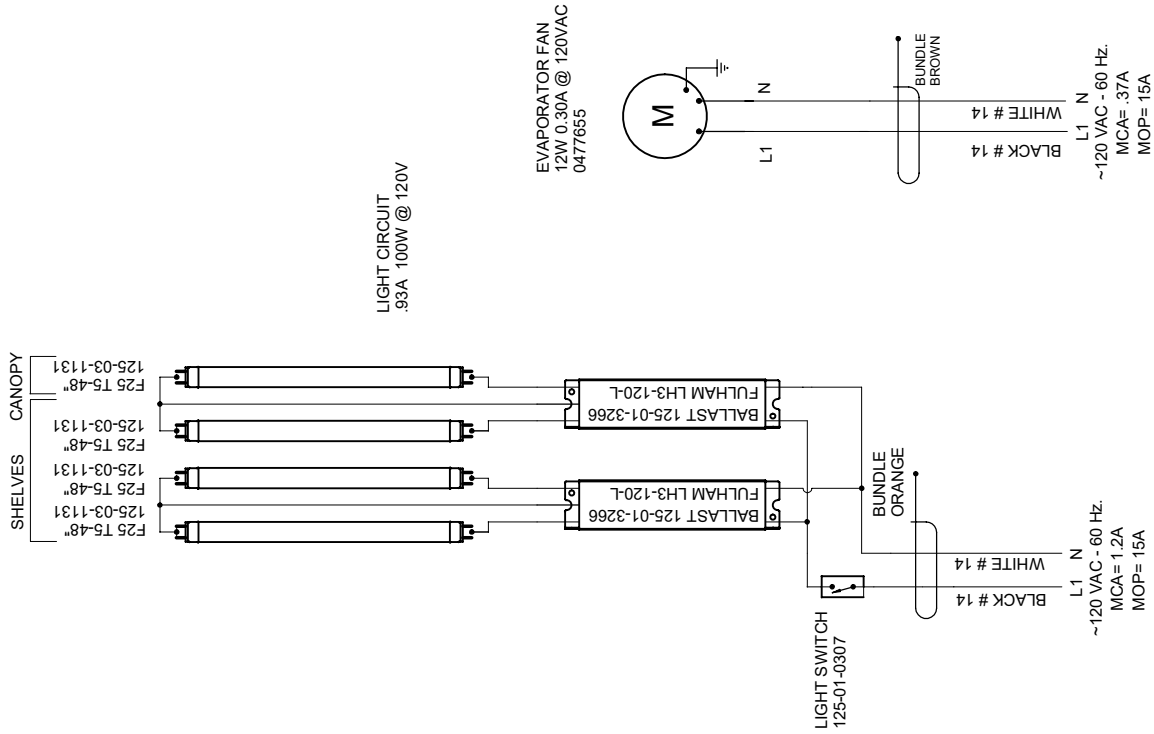

<b>HUSSMANN®</b> Hussmann Corporation, Int'l. 13770 Ramona Avenue Chino, CA 91710 (909) 590-4910 Lic #: 644406	REVISIONS:	DRAWN BY: CRAIG BOOREY	PROJECT TITLE: ISLA CASES	DRAWING #: 1H66308
	#	DATE:	CHECKED BY:	DATE: 11/17/11
	DESCRIPTION:	BY:	PRODUCTION ORDER #:	DRAWING TITLE:
			FILE LOCATION:	IM-04-C4-R, IM-04-I4-R W/T-5 LIGHTS
				PAGE 1 OF 1



# Wiring Diagrams (Cont'd)

CIRCUIT #1	LOADING
	120 V
L1	1.6

**NOTE: CASE MUST BE GROUNDED**

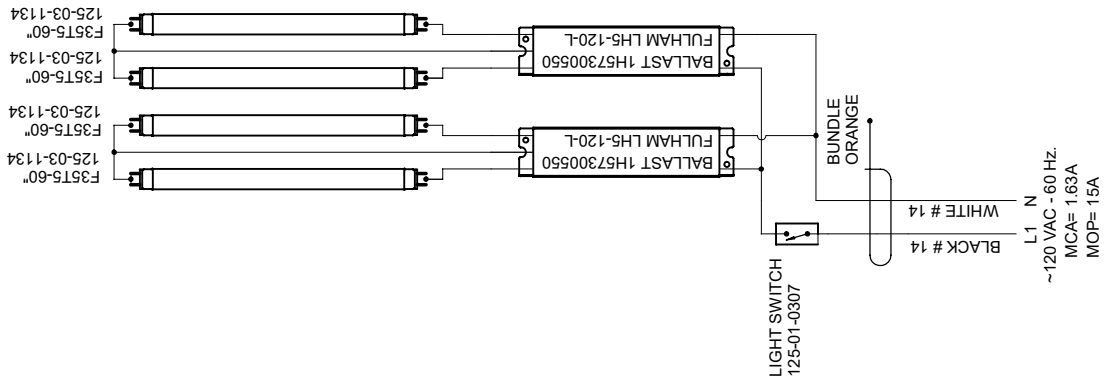

LIGHT CIRCUIT= 1.3A 140W

EVAPORATOR FAN  
12W 0.3A @ 120VAC  
0477655

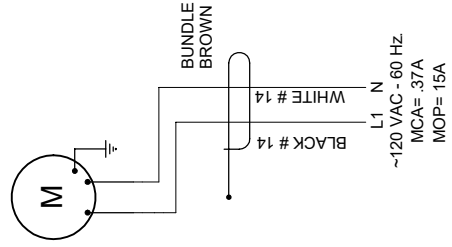

<p>Husmann Corporation, Int. 13770 Ramona Avenue Chino, CA. 91710 (909)-590-4910 Lc.#: 64406</p>	REVISIONS:	DRAWN BY: JESSE RIOS	PROJECT TITLE: ISLA CASES	DRAWING #: 1H19654	
	#	DATE:	CHECKED BY:	DATE: 2/25/09	
	C	6/7/10	JR	PRODUCTION ORDER #: 501398	
	D	8/5/11	CB	FILE LOCATION:	IM-04-C4-R, IM-04-E5-R W/T-5 LIGHTS
	E	11/18/11	CB		PAGE 1 OF 1

# Wiring Diagrams (Cont'd)

CIRCUIT #1	LOADING
	120 V
L1	1.6

**NOTE: CASE MUST BE GROUNDED**

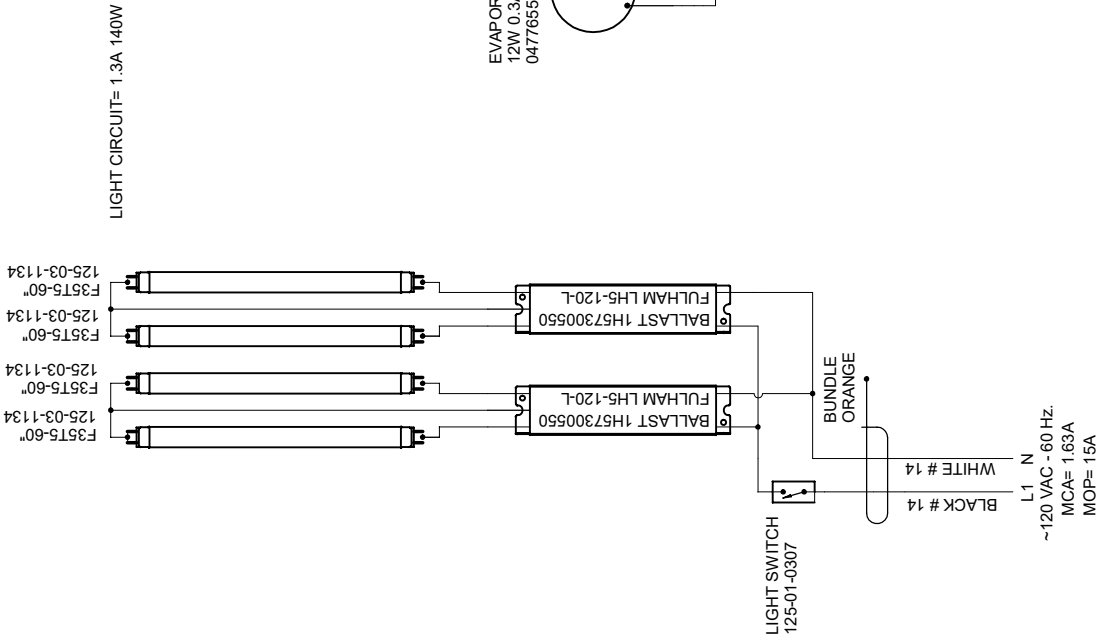

<b>HUSSMANN®</b> Hussmann Corporation, Int'l. 13770 Ramona Avenue Chino, CA 91710 (909) 590-4910 Lic.# 644406		REVISIONS:	DATE:	BY:	CHECKED BY:	DATE:	DRAWN BY:	PROJECT TITLE:	DRAWING #:
#	DESCRIPTION:	5/7/10	JR	PRODUCTION ORDER #:	501398	2/25/09	JESSE RIOS	ISLA CASES	1H19654
C	Made changes to reflect latest production models	8/5/11	CB	FILE LOCATION:					
D	Changed Ballast to Longhorse 5								
E	Changed Fan Motor	11/18/11	CB						

DRAWING TITLE:  
IM-04-C4-R, IM-04-15-R, IM-04-E5-R W/T-5 LIGHTS



# Wiring Diagrams (Cont'd)

CIRCUIT #1

LOADING
120 V
L1 2.7

**NOTE: CASE MUST BE GROUNDED**

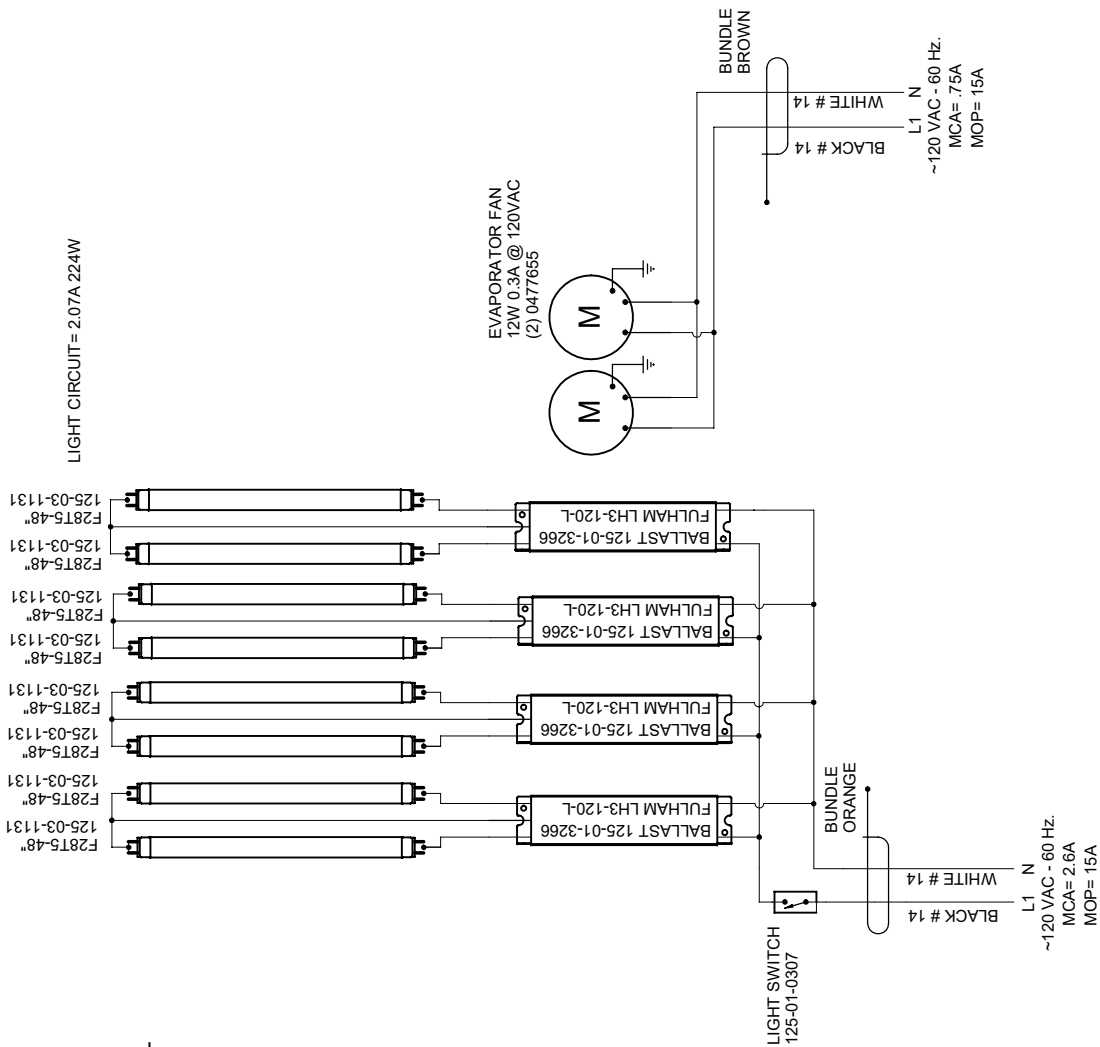

<b>REVISIONS:</b>		<b>DRAWN BY:</b> JESSE RIOS		<b>PROJECT TITLE:</b> ISLA CASES		<b>DRAWING #:</b> 1H21900	
#	DESCRIPTION:	DATE:	CHECKED BY:	DATE:	3/30/09		
B	Added optional heater tape	9/8/09	JR	PRODUCTION ORDER #:			
C	Removed Frostex	8/5/11	CB	FILE LOCATION:			
D	Changed Fan Motor	11/18/11	CB				
						<b>DRAWING TITLE:</b>	
						<b>IM-04-C8-R, IM-04-J8-R</b>	
<b>PAGE 1 OF 1</b>							



# Wiring Diagrams (Cont'd)

CIRCUIT #1

LOADING
120 V
L1 4.0

**NOTE: CASE MUST BE GROUNDED**

LIGHT CIRCUIT= 3.11A 336W

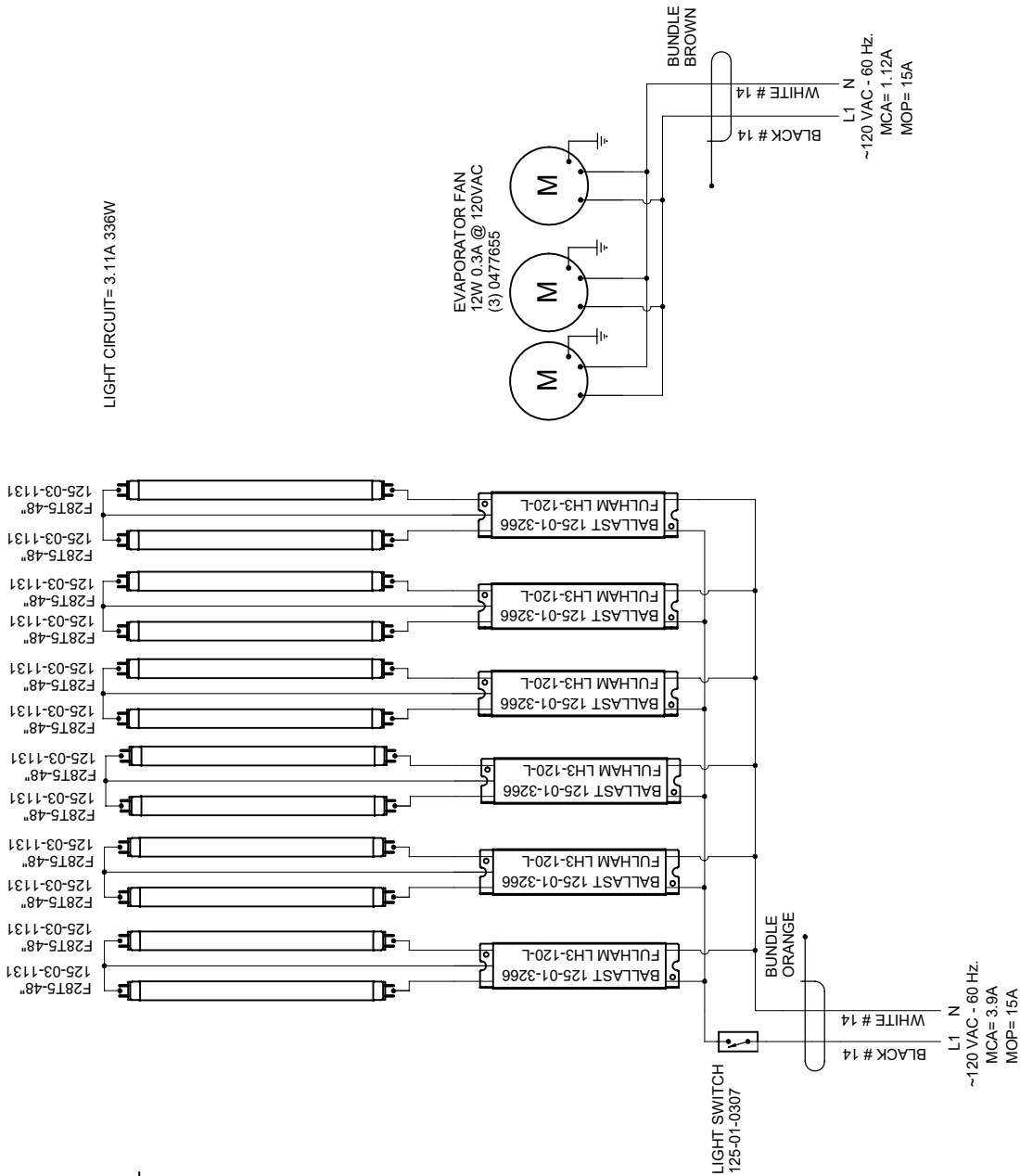

**HUSSMANN**  
 Hussmann Corporation, Int.  
 13770 Ramona Avenue  
 Chino, CA 91710  
 (909) 590-4910 Lic.#: 64406

REVISIONS:

#	DESCRIPTION:	DATE:	BY:	CHECKED BY:	DATE:
B	Dwg correction to ballast part numbers	2/27/09	JR	JESSE RIOS	2/25/09
C	Charliged Fan Motor	11/18/11	CB		

DRAWN BY: JESSE RIOS  
 CHECKED BY: JR  
 DATE: 11/18/11  
 PRODUCTION ORDER #: 501398  
 FILE LOCATION: CB

PROJECT TITLE: ISLA CASES  
 DRAWING TITLE: IM-04-C12-R, IM-04-112-R

DRAWING #: 1H19655

PAGE 1 OF 1

# Wiring Diagrams (Cont'd)

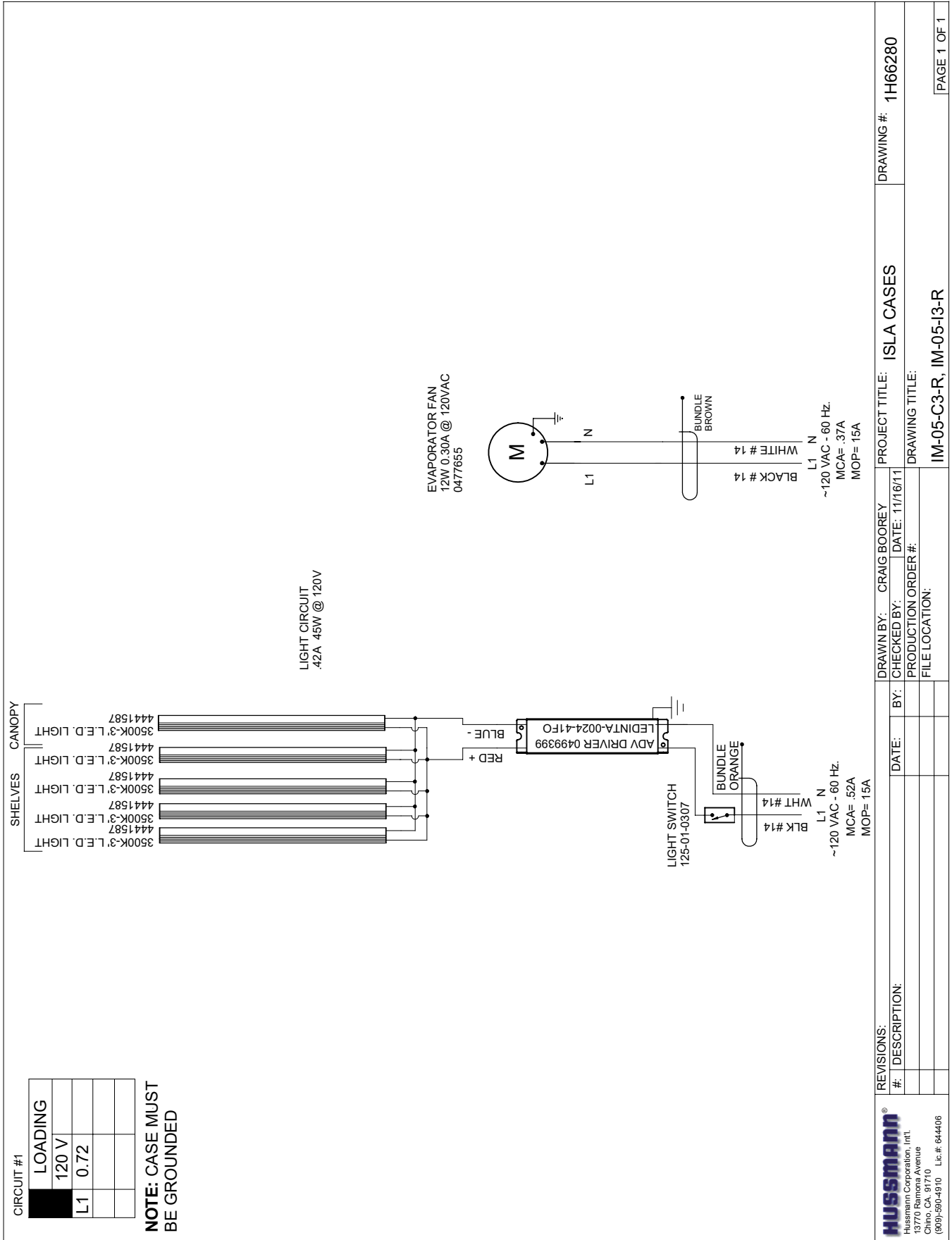

# Wiring Diagrams (Cont'd)

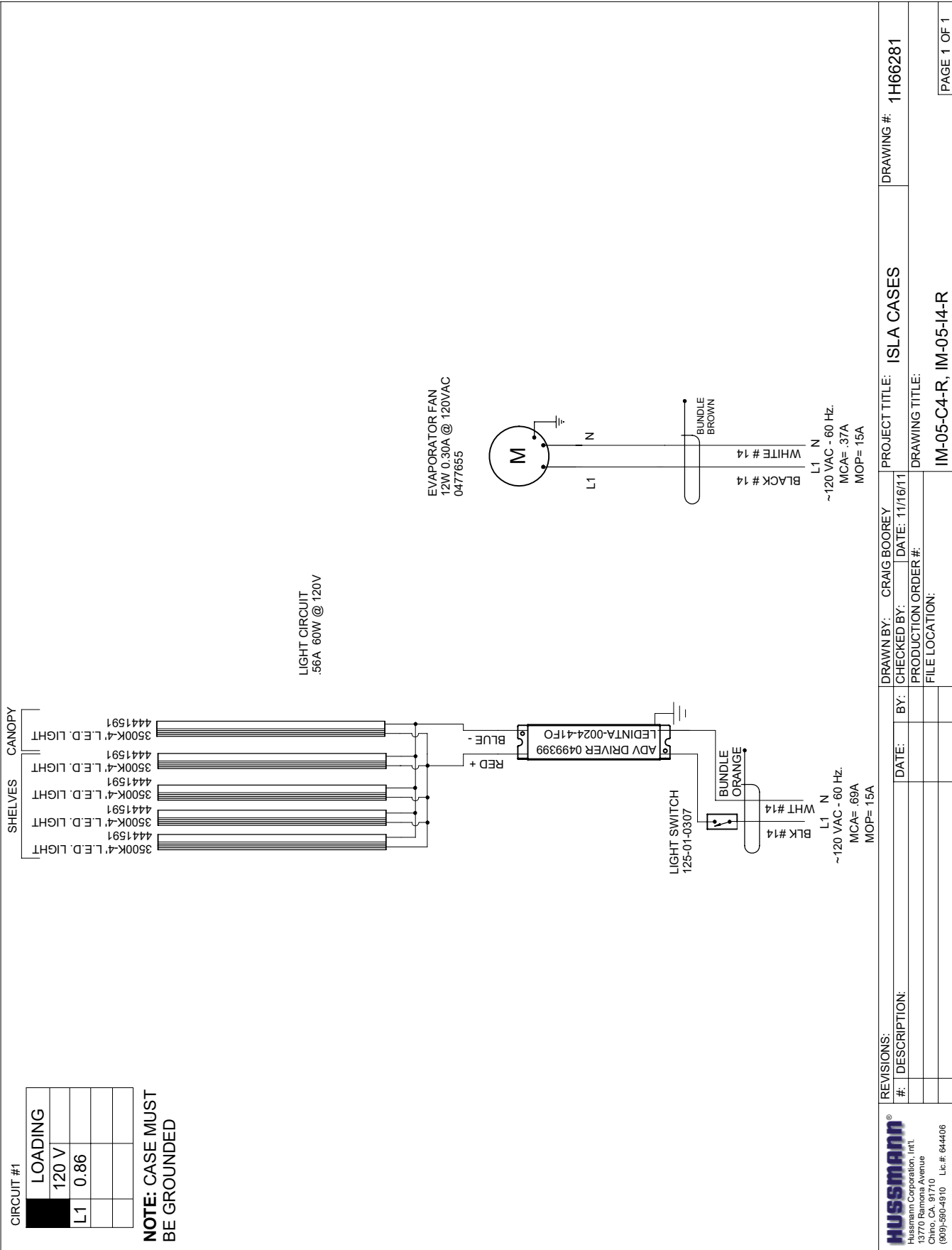



# Wiring Diagrams (Cont'd)

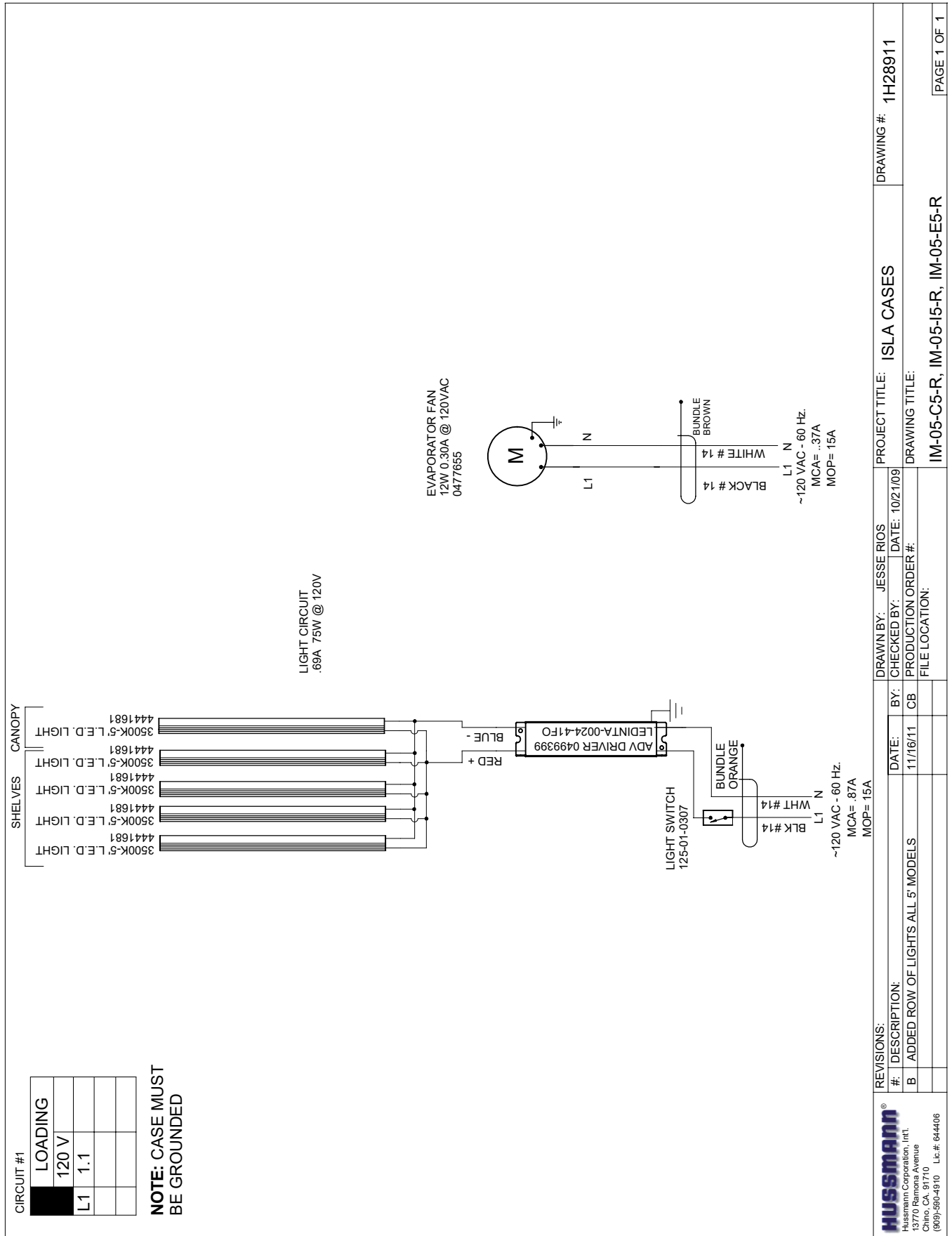

# Wiring Diagrams (Cont'd)

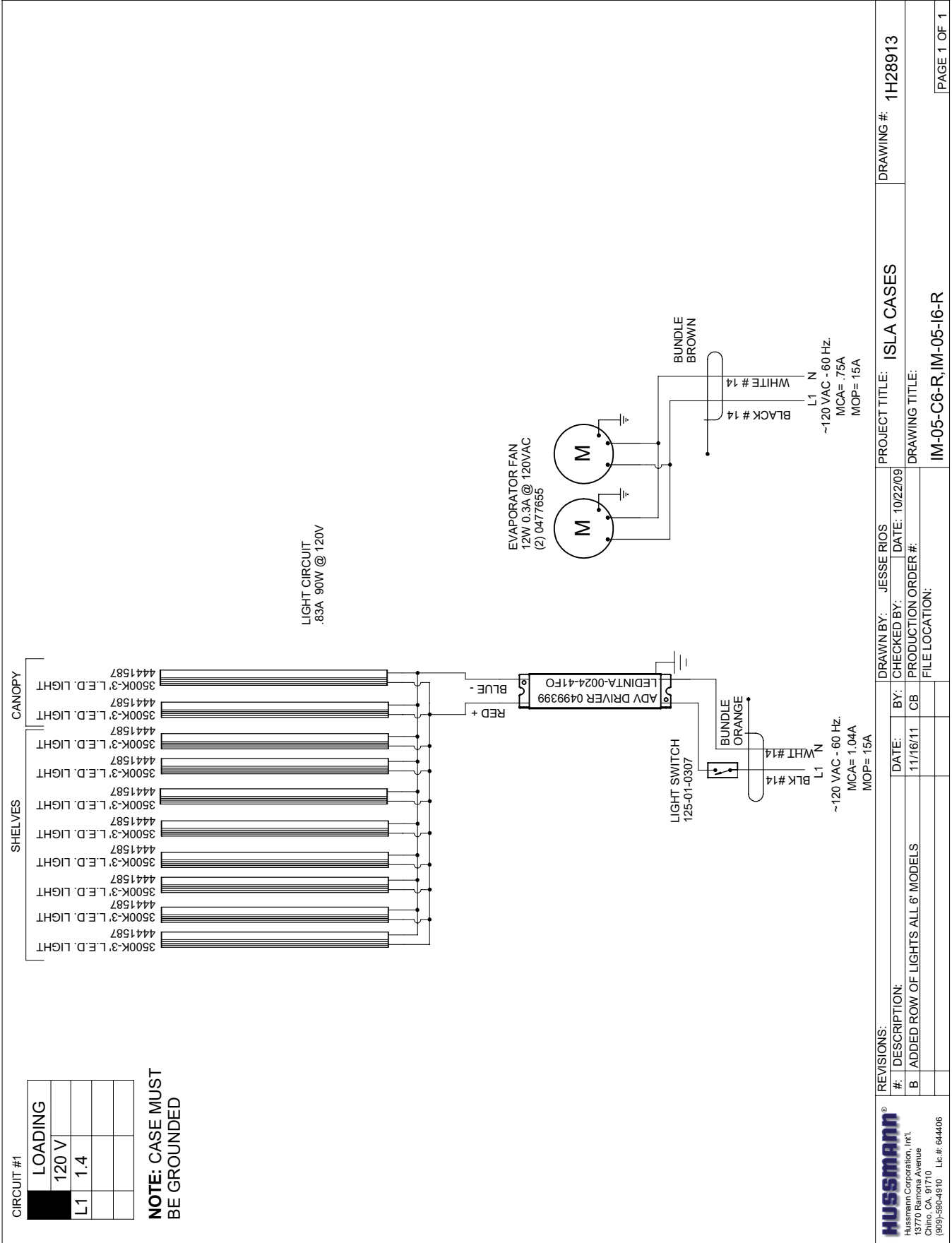

<b>REVISIONS:</b>		<b>PROJECT TITLE:</b> ISLA CASES	<b>DRAWING #:</b> 1H28913
#	DESCRIPTION:	<b>DRAWN BY:</b> JESSE RIOS	<b>DATE:</b> 10/22/09
B	ADDED ROW OF LIGHTS ALL 6 MODELS	<b>CHECKED BY:</b>	<b>DATE:</b> 11/16/11
		<b>PRODUCTION ORDER #:</b>	<b>FILE LOCATION:</b>
			IM-05-C6-R, IM-05-16-R
			PAGE 1 OF 1

**HUSSMANN**  
 Hussmann Corporation, Int'l.  
 13770 Ramona Avenue  
 Chino, CA 91710  
 (909) 590-4910 Lc.#: 64406

# Wiring Diagrams (Cont'd)

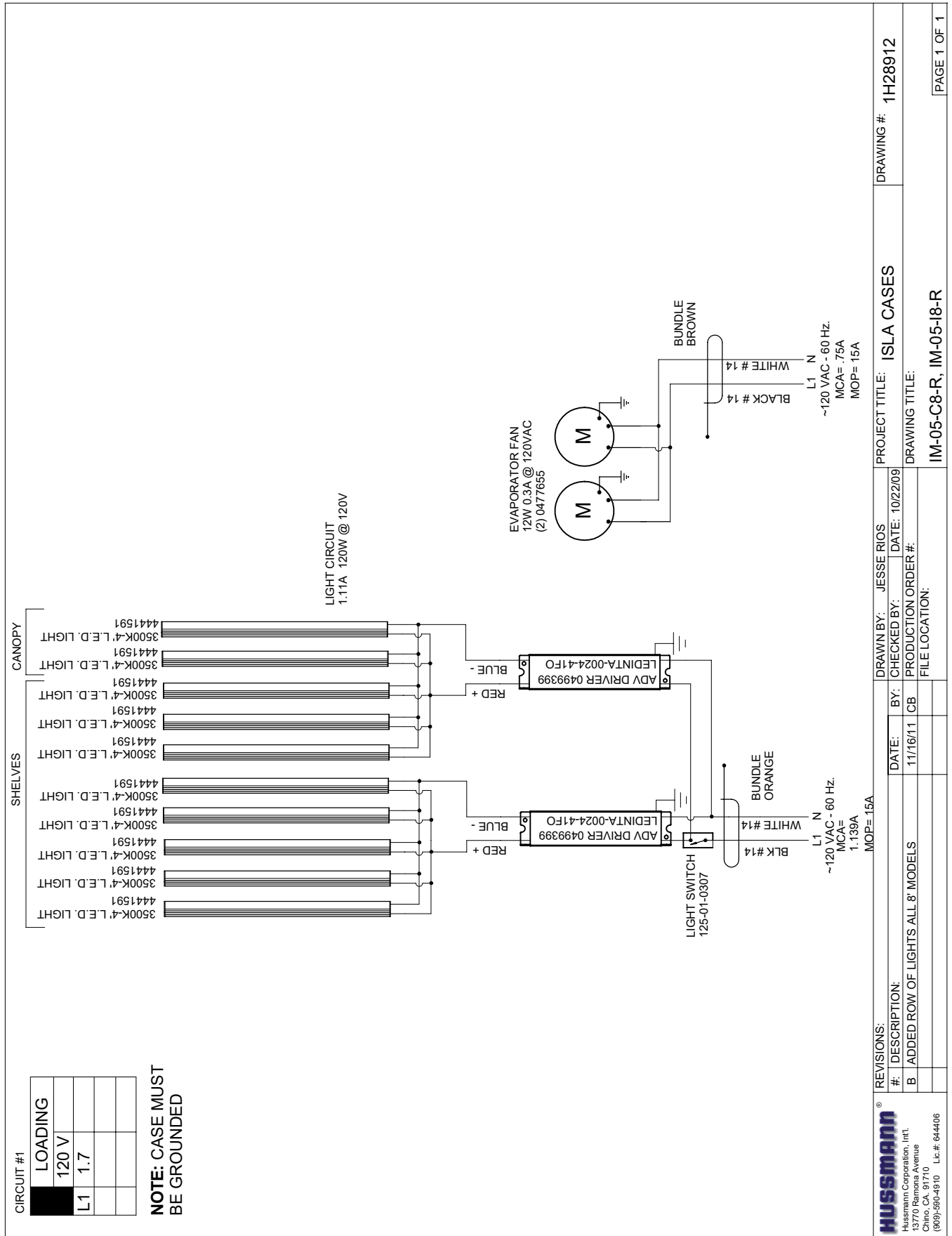

# Wiring Diagrams (Cont'd)

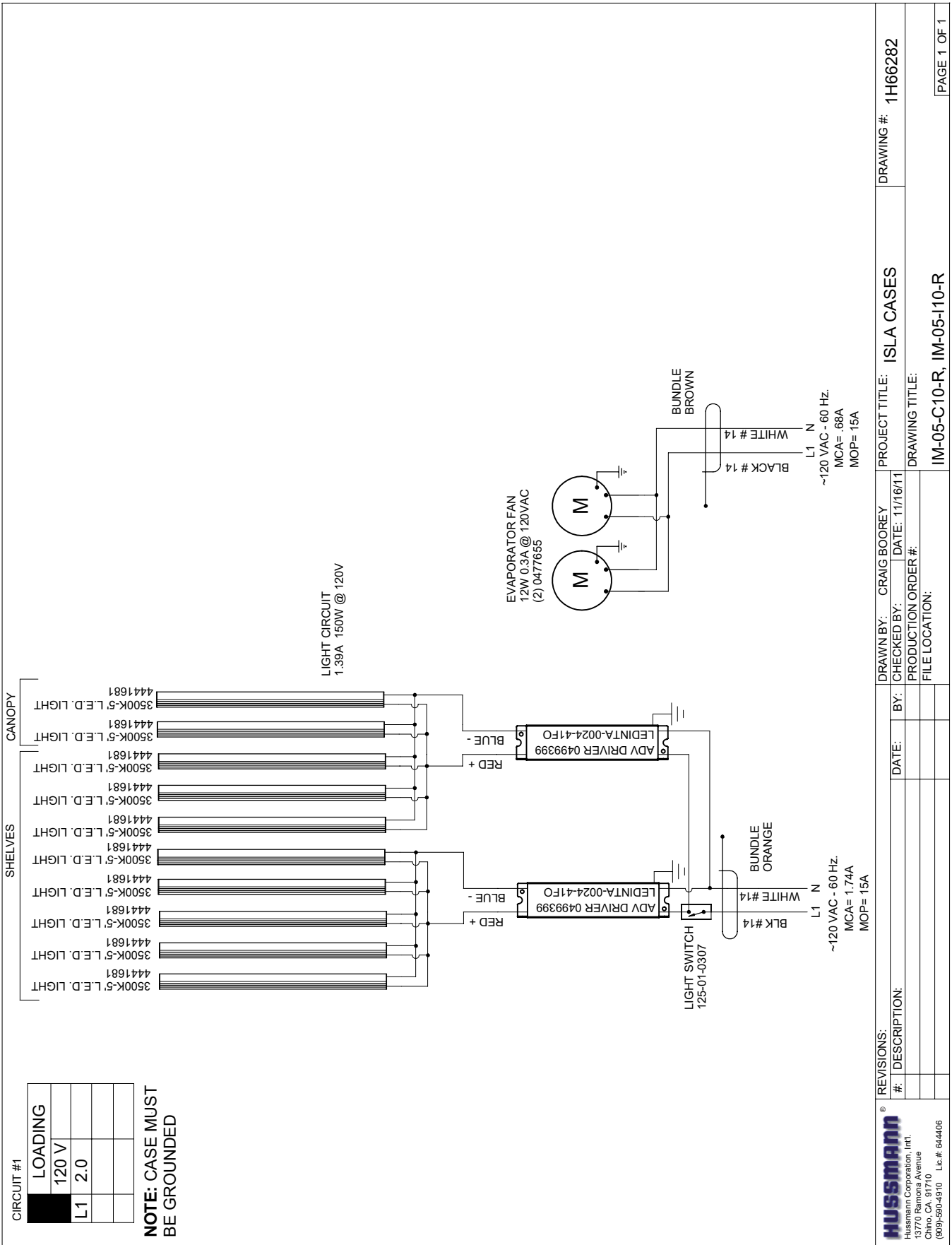

<b>REVISIONS:</b>	<b>DRAWN BY:</b> CRAIG BOOREY	<b>PROJECT TITLE:</b> ISLA CASES	<b>DRAWING #:</b> 1H66282
#	<b>DATE:</b>	<b>CHECKED BY:</b>	<b>DATE:</b> 11/16/11
		<b>PRODUCTION ORDER #:</b>	
		<b>FILE LOCATION:</b>	IM-05-C10-R, IM-05-110-R
			PAGE 1 OF 1

# Wiring Diagrams (Cont'd)

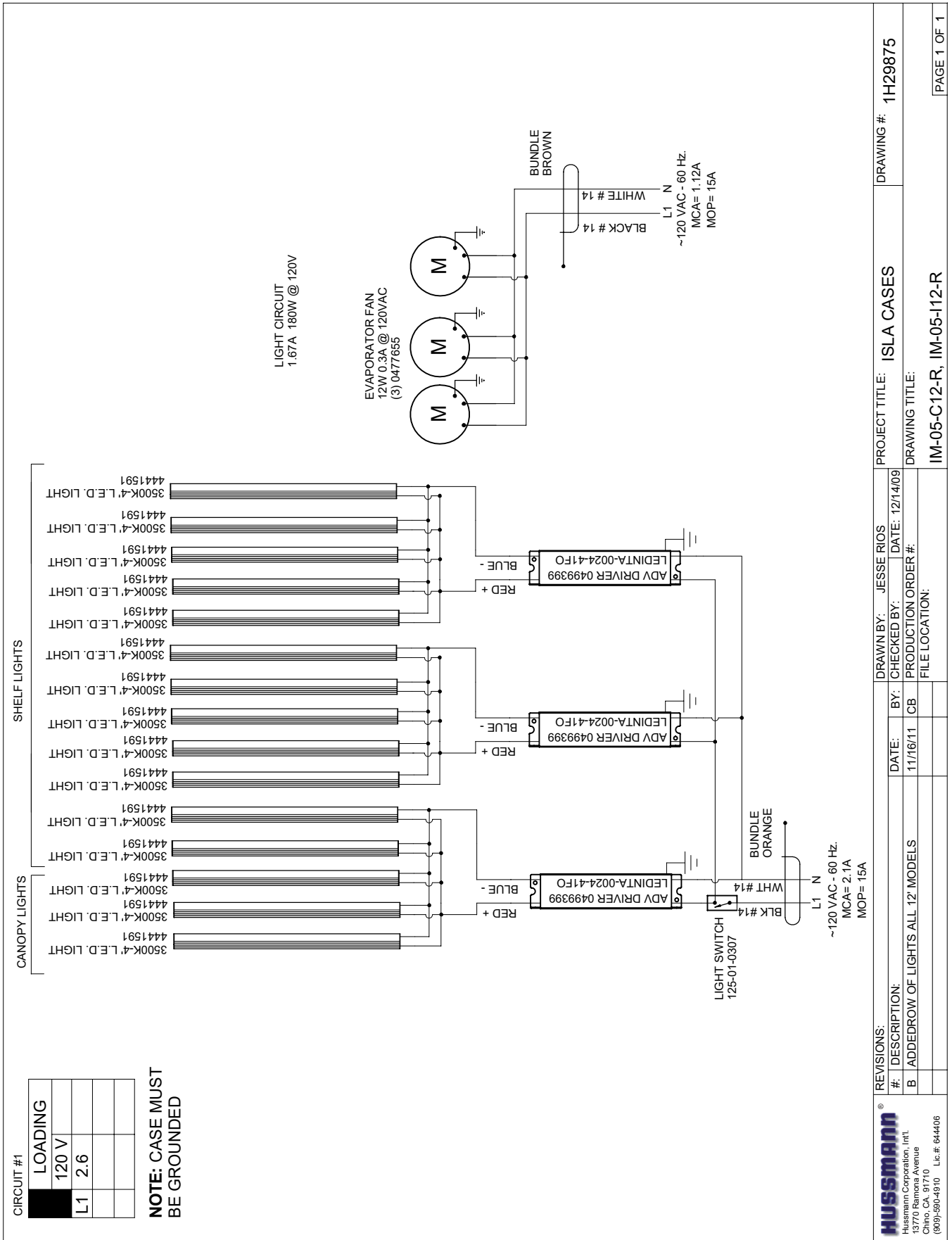



# Wiring Diagrams (Cont'd)

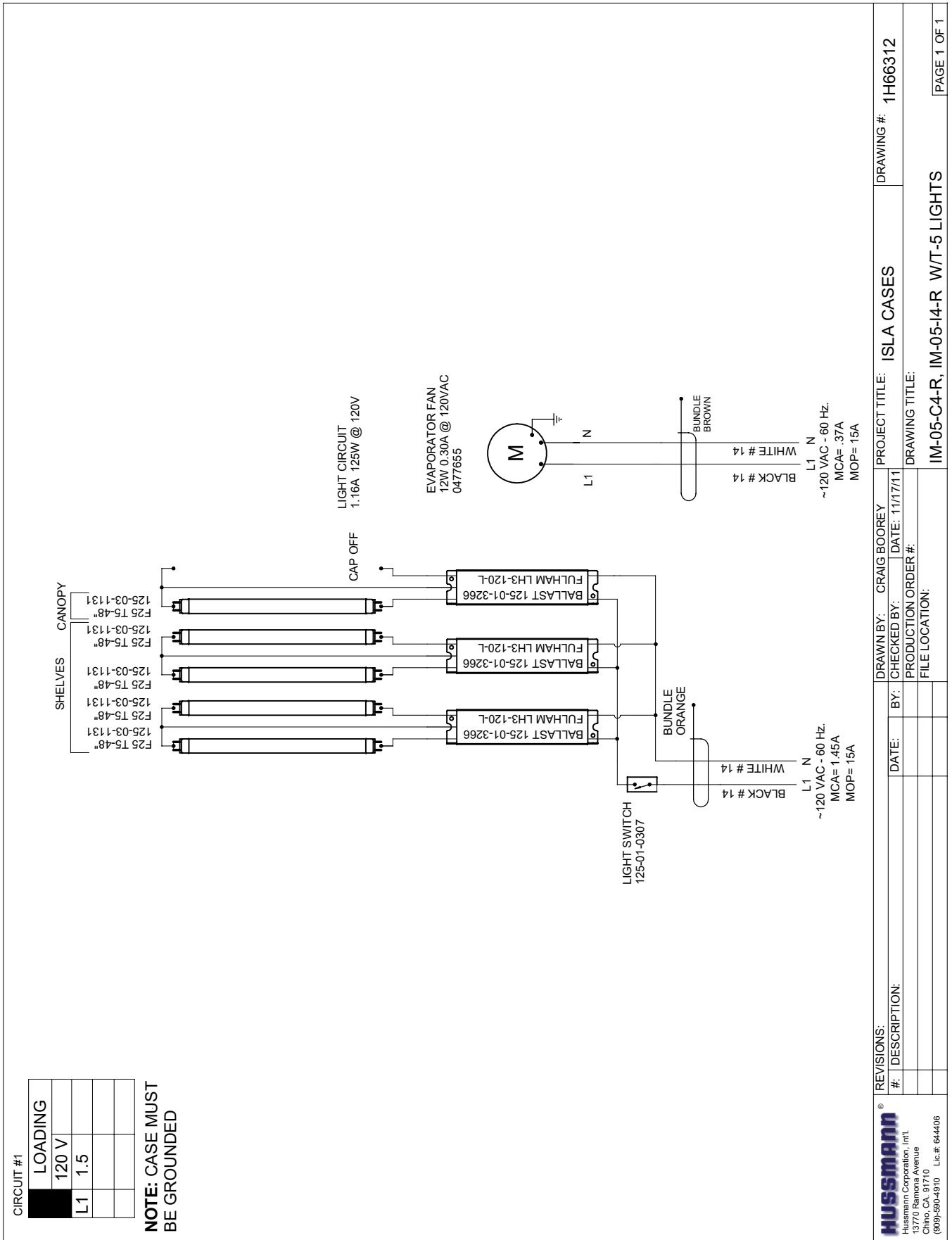





# Wiring Diagrams (Cont'd)

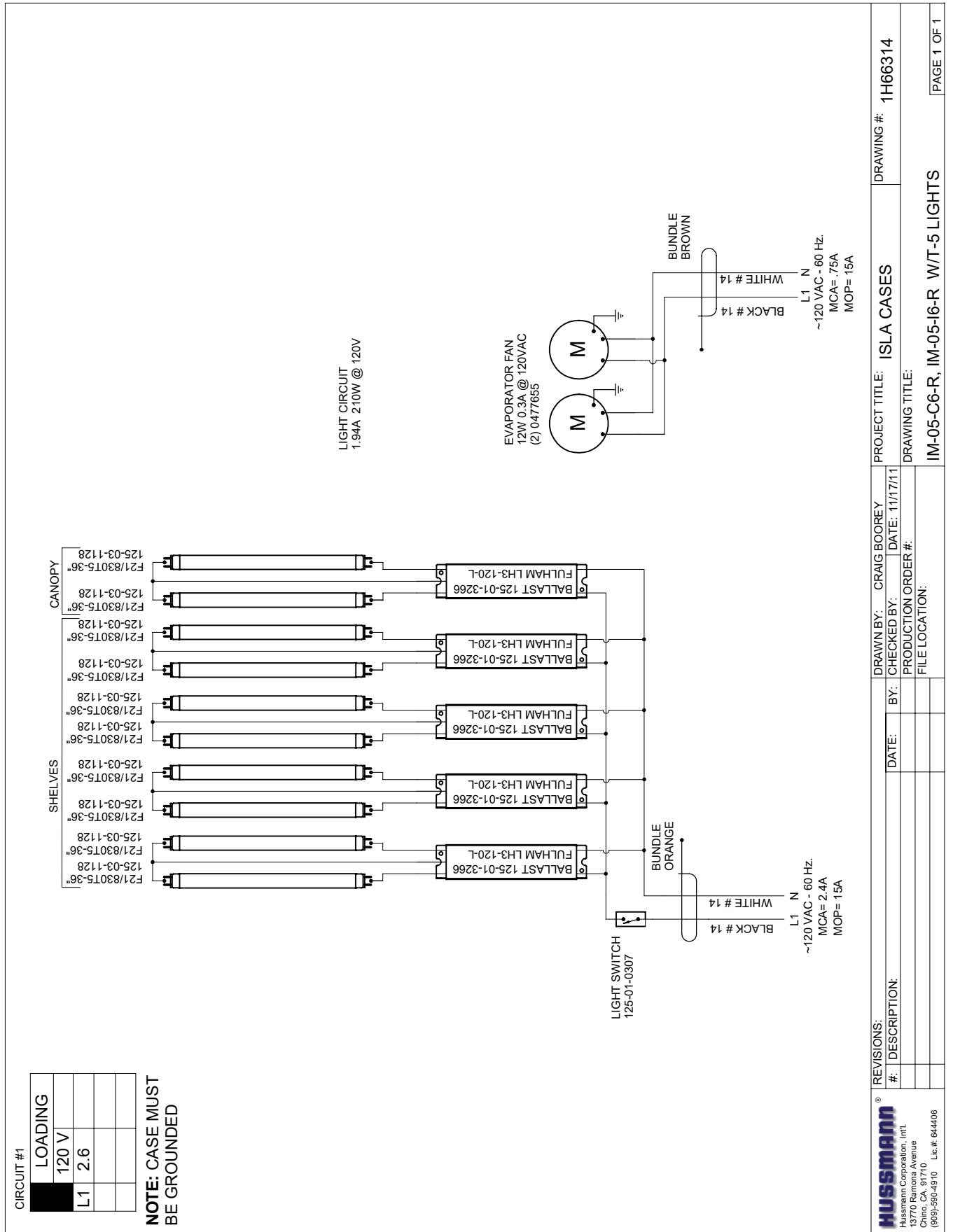



# Wiring Diagrams (Cont'd)

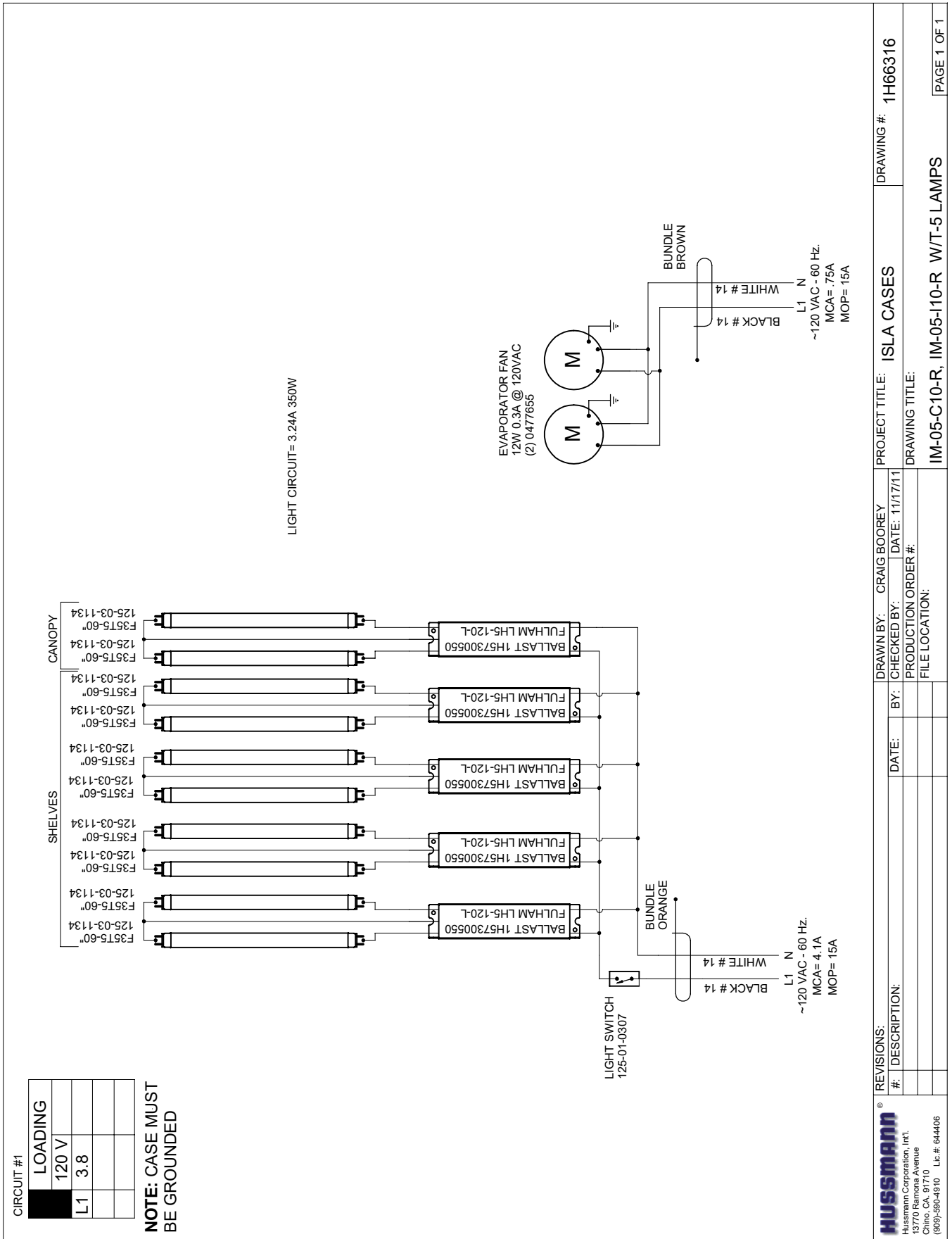

# Wiring Diagrams (Cont'd)

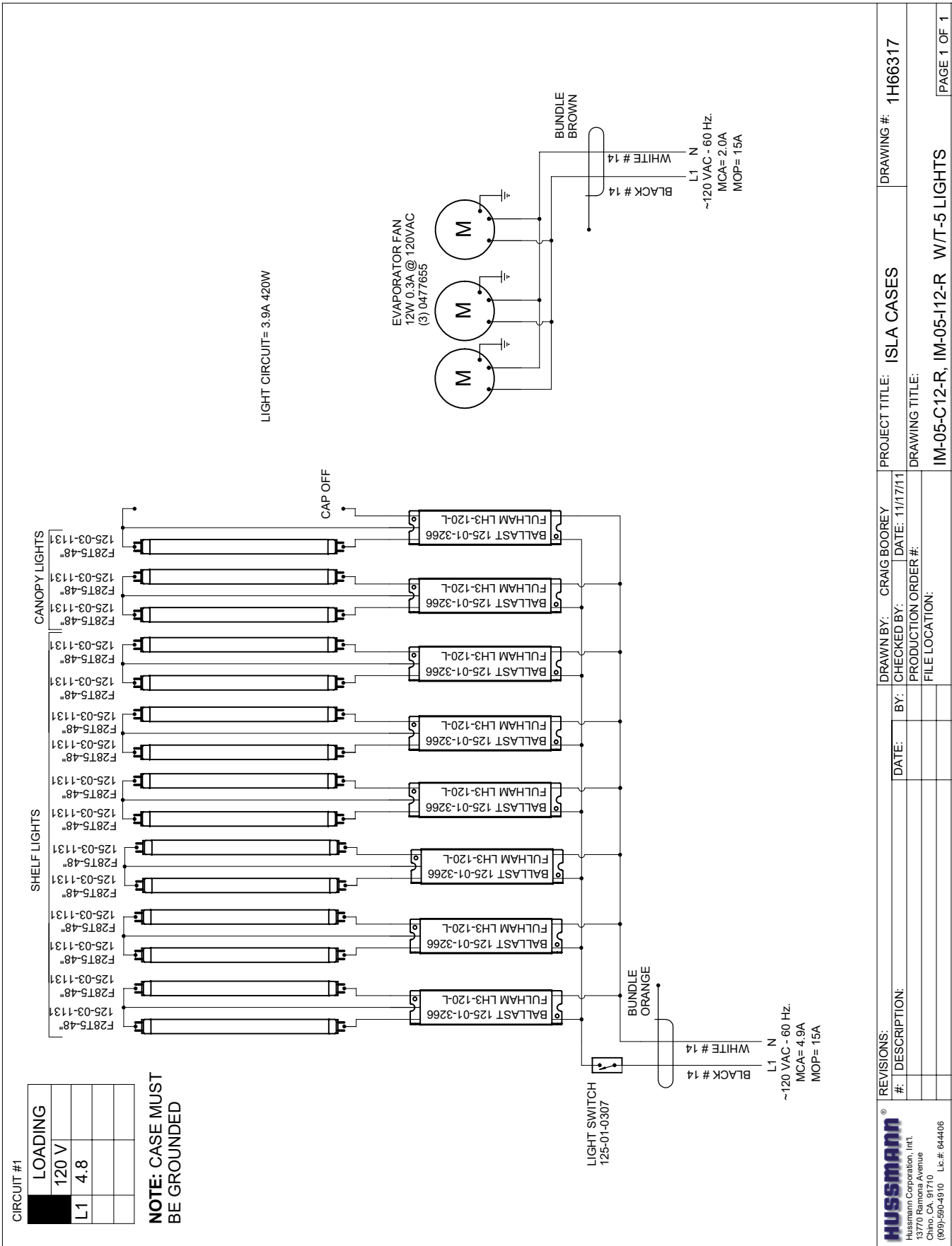

## 10. User Information

### Stocking

Improper temperature and lighting will cause serious product loss. Discoloration, dehydration and spoilage can be controlled with proper use of the equipment and handling of product. Product temperature should always be maintained at a constant and proper temperature. This means that from the time the product is received, through storage, preparation and display, the temperature of the product must be controlled to maximize life of the product. Hussmann cases were not designed to “heat up” or “cool down” product - but rather to maintain an item’s proper temperature for maximum shelf life. To achieve the protection required always:

1. Minimize processing time to avoid damaging temperature rise to the product. Product should be at proper temperature.
2. Keep the air in and around the case area free of foreign gasses and fumes or food will rapidly deteriorate.
3. Maintain the display merchandisers temperature controls as outlined in the refrigerator section of this manual.
4. Do not place any product into these refrigerators until all controls have been adjusted and they are operating at the proper temperature. Allow merchandiser to operate a minimum of 6 hours before stocking with any product.
5. When stocking, never allow the product to extend beyond the recommended load limit. Air discharge and return air flow must be unobstructed at all times to provide proper refrigeration.
6. Avoid the use of supplemental flood or spot lighting. Display light intensity has been designed for maximum visibility and product life at the factory. The use of higher output fluorescent lamps (H.O. and V.H.O.), will shorten the shelf life of the product.

### Important Steps

1. Do not set temperature too cold, as this causes product dehydration. Refer to the ISLA technical data sheet for proper settings.
2. Temperature control should be by means of a T-STAT and Suction Solenoid or equivalent for each case.

### Case Cleaning

Long life and satisfactory performance of any equipment are dependent upon the care given to it. To insure long life, proper sanitation and minimum maintenance costs, the refrigerator should be thoroughly cleaned frequently. SHUT OFF FAN DURING CLEANING PROCESS. It can be unplugged within the case, or shut off entire case at the source. The interior bottom may be cleaned with any domestic soap or detergent based cleaners. Sanitizing solutions will not harm the interior bottom, however, these solutions should always be used according to the Hussmann’s directions. It is essential to establish and regulate cleaning procedures. This will minimize bacteria causing discoloration which leads to degraded product appearance and significantly shortening product shelf life.

Soap and hot water are not enough to kill this bacteria. A sanitizing solution must be included with each cleaning process to eliminate this bacteria.

### Cases Without Sump Pumps

1. Scrub thoroughly, cleaning all surfaces, with soap and hot water.
2. Rinse with hot water, but do not flood.
3. Apply the sanitizing solution according to Hussmann’s directions.
4. Rinse thoroughly.
5. Dry completely before resuming operation.

### Cases With Sump Pumps



Do not rinse the interior of a case with sump pump drainage! Doing so will damage the pump, cause flooding and may result in serious personal injury

1. Scrub interior surface with a damp cleaning cloth rinsed in soapy water.
2. Use a sanitizing solution to scrub and clean all interior surfaces.
3. Wipe interior surfaces with a clean dry cloth.
4. Do not use a hose, high-pressure wash or running water.
5. Dry completely before resuming operation.

## User Information (Cont'd)

### Cleaning Glass and Mirrors

Only use a soft cloth and mild glass cleaner for cleaning any glass or mirrored components. Be sure to rinse and/or dry completely.

**Never use hot water on cold glass surfaces! It may shatter and cause serious injury! Allow glass surfaces to warm first.**

#### CAUTION

##### CLEANING PRECAUTIONS

When cleaning:

- Do not use high pressure water hoses
- Do not introduce water faster than waste outlet can drain
- NEVER INTRODUCE WATER ON SELF CONTAINED UNIT WITH AN EVAPORATOR FAN
- NEVER USE A CLEANING OR SANITIZING SOLUTION THAT HAS AN OIL BASE (these will dissolve the butyl sealants) or an AMMONIA BASE (this will corrode the copper components of the case)
- TO PRESERVE THE ATTRACTIVE FINISH:
- DO USE WATER AND A MILD DETERGENT FOR THE EXTERIOR ONLY
- DO NOT USE A CHLORINATED CLEANER ON ANY SURFACE
- DO NOT USE ABRASIVES OR STEEL WOOL SCOURING PADS (these will mar the finish)

### Plexiglass and Acrylic Care

#### Cleaning

Clean with plenty of nonabrasive soap (or detergent) and luke warm water, using the bare hand to feel and dislodge any caked-on dirt. A soft, grit-free cloth, sponge or chamois may be used, but only as a means of carrying the water to the plastic. Dry with a clean damp chamois or clean soft cloth such as cotton flannel. Hard, rough cloths or paper towels will scratch the acrylic and should not be used.

#### Waxing

If after removing dirt and grease, the acrylic can be waxed with a good grade commercial wax. This will improve the appearance of the surface by filling in most minor scratches. Wax should be applied in a thin even coat and brought to a high polish by rubbing lightly with a dry clean soft cloth, such as a cotton flannel. Excessive rubbing may cause scratching and/or buildup an electrostatic charge which attracts dust and dirt to the surface. Blotting with a clean damp cloth is recommended to remove charge.

#### Antistatic Coatings

For acrylic used indoors, antistatic coatings successfully prevent the accumulation of an electrostatic charge for periods of several months - if the surface is not washed or wiped down with a wet cloth. Between applications of the antistatic coatings, the parts need only be dusted with a soft clean cloth to maintain a good appearance. In use, liquid antistatic coatings should be applied in a very thin even coat. If beads appear as it is applied, the coat is too thick and the excess should be removed with another cloth. Allow the coating to dry, then bring to a high gloss with a soft cloth.

#### Cleaning Front Glass Channel

To clean the front-glass channel:

1. With two hands carefully lift the glass out of the channel,
2. Remove any debris from the channel,
3. Replace the glass.

Frequency: Monthly or as-required.

## 11. Shelf Weight Limits

Depth of Shelf	Maximum Load Limit
10 in (254 mm)	250 lb (113.4 kg)
12 in (305 mm)	250 lb (113.4 kg)
14 in (356 mm)	250 lb (113.4 kg)
16 in (407 mm)	250 lb (113.4 kg)
18 in (457 mm)	250 lb (113.4 kg)

\* Shelf load limits at 0° tilt

Husmann® merchandiser shelves are designed to support the maximum weight load limits as indicated in the table above. Exceeding these maximum weight load limits may cause damage to the shelf or shelves, damage to the merchandiser, damage to store products, and potentially create a hazardous condition for customers and staff. Exceeding the indicated maximum weight load limits constitutes misuse as described in the Husmann® Limited Warranty.

## 12. Maintenance

### Electrical Precautions



**DANGER**

BEFORE SERVICING  
ALWAYS DISCONNECT ELECTRICAL  
POWER AT THE MAIN DISCONNECT  
WHEN SERVICING OR REPLACING ANY  
ELECTRICAL COMPONENT.  
This includes (but not limited to) Fans, Heaters  
Thermostats, and Lights.

### **CAUTION**

Fluorescent Lamps contain mercury vapor. Mercury exposure at high levels can harm the brain, heart, kidneys, lungs and immune system of people of all ages. Do not break or puncture fluorescent lamps. Dispose of, or store, all fluorescent lamps in accordance with Federal (40 CFR 273), State and local hazardous waste requirements. Refer to <http://www.epa.gov/mercury/about.htm>

Fluorescent Lamp Disposal: The United States Environmental protection Agency has information regarding environmentally-safe fluorescent lamp waste management programs.

On the Net: EPA Web site:

<http://www.epa.gov/osw/hazard/wastetypes/universal/lamps/recycle.htm>

### Replacing Fluorescent Lamps

Fluorescent lamps are furnished with a shatterproof protective coating. The same type of lamp with protective coating must be used if replaced.

### Evaporator Fans

The evaporator fans are located at the center front of these merchandisers directly beneath the display pans. Should fans or blades need servicing, always replace fan blades with the raised embossed side of the blade TOWARD THE MOTOR.

### Tips and Troubleshooting

Before calling for service, check the following:

1. Check electrical power supply to the equipment for connection.
2. Check fixture loading. Overstocking case will affect its proper operation.
3. If frost is collecting on fixture and/or product, check that Humidity Control is working properly, and that no outside doors or windows are open - allowing moisture to enter store.



**IMPORTANT  
INFORMATION**

FOR PROMPT SERVICE  
When contacting the factory regarding problems, be sure to have the Case Model and Serial Number handy. This information is on a plate located on the case itself.

### Stainless Steel Cleaning and Care

There are three basic things, which can break down your stainless steel's passivity layer and allow corrosion.

#### 1. Mechanical Abrasion

Mechanical Abrasion means those things that will scratch the steel's surface. Steel Pads, wire Brushes, and Scrapers are prime examples.

#### 2. Water

Water comes out of our tap in varying degrees of hardness. Depending on what part of the country you live in, you may have hard or soft water. Hard water may leave spots. Also, when heated, hard water leaves deposits behind that if left to sit, will break down the passive layer and rust your stainless steel. Other deposits from food preparation and service must be properly removed.

#### 3. Chlorides

Chlorides are found nearly everywhere. They are in water, food and table salt. One of the worst perpetrators of chlorides can come from household and industrial cleaners.

Don't Despair! Here are a few steps that can help prevent stainless steel rust.

#### 1. Use the Proper Tools

When cleaning your stainless steel products, take care to use non-abrasive tools. Soft Clothes and plastic scouring pads will NOT harm the steel's passive layer. Stainless steel pads can also be used but the scrubbing motion must be in the same direction of the manufacturer's polishing marks.

#### 2. Clean With the Polish Lines

Some stainless steels come with visible polishing lines or "grain". When visible lines are present, you

## Maintenance (Cont'd)

should ALWAYS scrub in a motion that is parallel to them. When the grain cannot be seen, play it safe and use a soft cloth or plastic scouring pad.

### 3. Use Alkaline, Alkaline Chlorinated or Non-chloride Containing Cleaners

While many traditional cleaners are loaded with chlorides, the industry is providing an ever increasing choice of non-chloride cleaners. If you are not sure of your cleaner's chloride content contact your cleaner supplier. If they tell you that your present cleaner contains chlorides, ask for an alternative. Also, avoid cleaners containing quaternary salts as they also can attack stainless steel & cause pitting and rusting.

### 4. Treat your Water

Though this is not always practical, softening hard water can do much to reduce deposits. There are certain filters that can be installed to remove distasteful and corrosive elements. Salts in a properly maintained water softener are your friends. If you are not sure of the proper water treatment, call a treatment specialist.

### 5. Keep your Food Equipment Clean

Use alkaline, alkaline chlorinated or non-chlorinated cleaners at recommended strength. Clean frequently to avoid build-up of hard, stubborn stains. If you boil water in your stainless steel equipment, remember the single most likely cause of damage is chlorides in the water. Heating cleaners that contain chlorides has a similar effect.

### 6. RINSE, RINSE, RINSE

If chlorinated cleaners are used you must rinse, rinse, rinse and wipe dry immediately. The sooner you wipe off standing water, especially when sit contains cleaning agents, the better. After wiping the equipment down, allow it to air dry for the oxygen helps maintain the stainless steel's passivity film.

### 7. Never Use Hydrochloric Acid (Muriatic Acid) on Stainless Steel

### 8. Regularly Restore/Passivate Stainless Steel

---

## CLEANING COILS

Never use sharp objects around coils. Use a soft brush or vacuum brush to clean debris from coils. Do not puncture coils! Do not bend fins. Contact an authorized service technician if a coil is punctured, cracked, or otherwise damaged.

**Do NOT use chlorine or ammonia-based cleaners to clean aluminum coils.**

ICE in or on the coil indicates the refrigeration and defrost cycle is not operating properly. Contact an authorized service technician to determine the cause of icing, and to make adjustments as necessary. To maintain product integrity, move all product to a cooler until the unit has returned to normal operating temperatures.





HUSSMANN Tech Support: 866-785-8499

## Troubleshooting Guide (Cold Case)

Problem	Possible Cause	Possible Solution
<b>Case temperature is too warm.</b>	Ambient conditions may be affecting the case operation.	Check case position in store. Is the case located near an open door, window, electric fan or air conditioning vent that may cause air currents? Case must be located minimum 15 Ft away from doors or windows. Cases are designed to operate at 55% Relative humidity and a temperature of 75°F.
	Discharge air temp is out of spec.	Check evaporator fan operation. Check electrical connections and input voltage.
		Fans are installed backwards. Check airflow direction.
		Fan blades are installed incorrectly. Make sure fan blades have correct pitch and are per specification.
		Check to see that fan plenum is installed correctly. It should not have any gaps.
		Check suction pressure and insure that it meets factory specifications.
	Place prepackaged hot food in case.	
	Case is in defrost.	Check defrost settings. See Technical Specifications section.
	Product load may be over its limits blocking airflow.	Redistribute product so it does not exceed load level. There is a sticker on the inside of the case indicating what the maximum load line is.
Coil is freezing over.	Return air is blocked, make sure debris is not blocking the intake section.	
	Coil close-offs are not installed. Inspect coil to make sure these parts are on the case.	
Condensing coil or evaporator coil is clogged or dirty.	Clean coil. Do NOT use chlorine or ammonia-based cleaners to clean aluminum coils.	
<b>Case temperature is too cold.</b>	The t-stat temp is set too low.	Check settings. See Technical Specifications section.
	Ambient conditions may be affecting the case operation.	Check case position in store. Is the case located near an open door, window, electric fan or air conditioning vent that may cause air currents? Case must be located minimum 15 Ft away from doors or windows. Cases are designed to operate at 55% Relative humidity and a temperature of 75°F.
	Inadequate air circulation.	Check if air sweep fans are functioning, check electrical connections.
	There is not enough heat provided in the airflow.	Check if air sweep heater is functioning, check electrical connections.
	There are glass gaps on the side of the case.	See glass adjustment section.
	Glass is not completely shut.	Close glass correctly.

## Troubleshooting (Cont'd)

Problem	Possible Cause	Possible Solution
<b>Water has pooled under case.</b>	Case drain is clogged.	Clear drain.
	PVC drains under case may have a leak.	Repair as needed.
	Case tub has unsealed opening.	Seal as needed.
	If the case is in a line-up, case to case joint is missing or unsealed.	Install case to case joint and seal as needed.
	Evaporator pan is overflowing (if applicable).	Check electrical connection to evaporator pan. Check float assembly, it should move freely up and down the support stem. Clear any debris.
<b>Case is not draining properly.</b>	Case is not level.	Level the case.
	Drain screen is plugged.	Clean drain screen and remove any debris.
	Drain or P-trap is clogged.	Clear any debris.
<b>Frost or ice on evaporator coil.</b>	Evaporator fans are not functioning.	Check electrical connections.
	Defrost clock is not functioning.	Case should be serviced by a qualified service technician.
	Coil is freezing over.	Return air is blocked, make sure debris is not blocking the intake section. Coil close-offs are not installed. Inspect coil to make sure these parts are on the case.
<b>Large gap is visible on bottom of front glass or glass can't be opened because it is too low.</b>	Glass Height adjusters need to be adjusted.	See Glass Adjustment section.
<b>Large gaps are visible in between glass panels or glass rubs against end panel.</b>	Glass/glass clamp assembly needs to be adjusted.	See Glass Adjustment section.
<b>Front glass does not stay open and falls closed.</b>	Glass shock/piston may need to be replaced.	Case should be serviced by a qualified service technician.
<b>Lights do not come on.</b>	Ballast/light socket wiring.	Check electrical connections. See Electrical Section and check wiring diagram.
	Ballast needs to be replaced.	Case should be serviced by a qualified service technician. See Electrical Section.
	Lamp socket needs to be replaced.	Case should be serviced by a qualified service technician.
	Lamp needs to be replaced.	See Maintenance Section.
	Light Switch needs to be replaced.	Case should be serviced by a qualified service technician.

# 14. Appendices

## Appendix A. - Temperature Guidelines

The refrigerators should be operated according to the manufacturer's published engineering specifications for entering air temperatures for specific equipment applications. Table 1 shows the typical temperature of the air entering the food zone one hour before the start of defrost and one hour after defrost for various categories of refrigerators. Refer to Appendix C for Field Evaluation Guidelines.

Type of Refrigerator	Typical Entering Air Temperature
<b>I. OPEN DISPLAY</b>	
A. Non frozen:	
1) Meat	28°F
2) Dairy/Deli	32°F
3) Produce	
a. Processed	36°F
b. Unprocessed	45°F
B. Frozen	0°F
C. Ice Cream	-5°F
<b>II. CLOSED DISPLAY</b>	
A. Non frozen:	
1) Meat	34°F
2) Dairy/Deli	34°F
3) Produce	
a. Processed	36°F
b. Unprocessed	45°F
B. Frozen	0°F
C. Ice Cream	-5°F

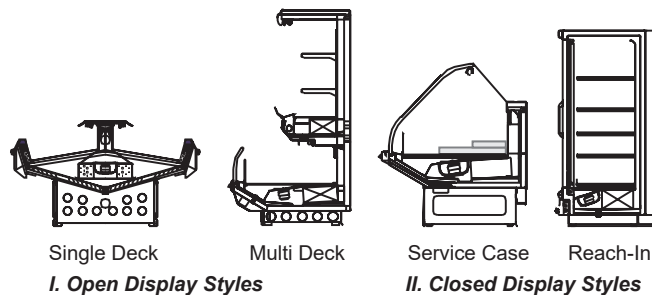

## Appendix B. - Application Recommendations

- 1.0 Temperature performance is critical for controlling bacteria growth. Therefore, the following recommendations are included in the standard. They are based on confirmed field experience over many years.
- 1.1 The installer is responsible for following the installation instructions and recommendations provided by Hussmann for the installation of each individual type refrigerator.
- 1.2 Refrigeration piping should be sized according to

the equipment manufacturer's recommendations and installed in accordance with normal refrigeration practices. Refrigeration piping should be insulated according to Hussmann's recommendations.

- 1.3 A clogged waste outlet blocks refrigeration. The installer is responsible for the proper installation of the system which dispenses condensate waste through an air gap into the building indirect waste system.
- 1.4 The installer should perform a complete start-up evaluation prior to the loading of food into the refrigerator, which includes such items as:
  - a) Initial temperature performance, Coils should be properly fed with a refrigerant according to manufacturer's recommendations.
  - b) Observation of outside influences such as drafts, radiant heating from the ceiling and from lamps. Such influence should be properly corrected or compensated for.
  - c) At the same time, checks should be made of the store dry-bulb and wet-bulb temperatures to ascertain that they are within the limits prescribed by Hussmann.
  - d) Complete start-up procedures should include checking through a defrost to make certain of its adequate frequency and length without substantially exceeding the actual needs. This should include checking the electrical or refrigerant circuits to make sure that defrosts are correctly programmed for all the refrigerators connected to each refrigeration system.
  - e) Recording instruments should be used to check performance.

## Appendix C. - Field Recommendations

### Recommendations for field evaluating the performance of retail food refrigerators and hot cases

- 1.0 The most consistent indicator of display refrigerator performance is temperature of the air entering the product zone (see Appendix A). In practical use, the precise determination of return air temperature is extremely difficult. Readings of return air temperatures will be variable and results will be inconsistent. The product temperature alone is not an indicator of refrigerator performance.

## Appendices (Cont'd)

**NOTE:** Public Health will use the temperature of the product in determining if the refrigerator will be allowed to display potentially hazardous food. For the purpose of this evaluation, product temperature above the FDA Food Code 1993 temperature for potentially hazardous food will be the first indication that an evaluation should be performed. It is expected that all refrigerators will keep food at the FDA Food Code 1993 temperature for potentially hazardous food.

- 1.1 The following recommendations are made for the purpose of arriving at easily taken and understood data which, coupled with other observations, may be used to determine whether a display refrigerator is working as intended:
- a) **INSTRUMENT** - A stainless steel stem-type thermometer is recommended and it should have a dial a minimum of 1 inch internal diameter. A test thermometer scaled only in Celsius or dually scaled in Celsius and Fahrenheit shall be accurate to 1°C (1.8°F). Temperature measuring devices that are scaled only in Fahrenheit shall be accurate to 2°F. The thermometer should be checked for proper calibration. (It should read 32°F when the stem is immersed in an ice water bath).
  - b) **LOCATION** - The probe or sensing element of the thermometer should be located in the airstream where the air first enters the display or storage area, and not more than 1 inch away from the surface and in the center of the discharge opening.
  - c) **READING** - It should first be determined that the refrigerator is refrigerating and has operated at least one hour since the end of the last defrost period. The thermometer reading should be made only after it has been allowed to stabilize, i.e., maintain a constant reading.
  - d) **OTHER OBSERVATIONS** - Other observations should be made which may indicate operating problems, such as unsatisfactory product, feel/appearance.
  - e) **CONCLUSIONS** - In the absence of any apparent undesirable conditions, the refrigerator should be judged to be operating properly. If it is determined that such condition is undesirable, i.e., the product is above proper temperature, checks should be made for the following:
    1. Has the refrigerator been loaded with warm product?
    2. Is the product loaded beyond the "Safe Load Line" markers?

3. Are the return air ducts blocked?
4. Are the entering air ducts blocked?
5. Is a dumped display causing turbulent air flow and mixing with room air?
6. Are spotlights or other high intensity lighting directed onto the product?
7. Are there unusual draft conditions (from heating/air-conditioning ducts, open doors, etc.)?
8. Is there exposure to direct sunlight?
9. Are display signs blocking or diverting airflow?
10. Are the coils of the refrigerator iced up?
11. Is the store ambient over 75°F, 55% RH as set forth in ASHRAE Standard 72 and ASHRAE Standard 117?
12. Are the shelf positions, number, and size other than recommended by Hussmann?
13. Is there an improper application or control system?
14. Is the evaporator fan motor/blade inoperative?
15. Is the defrost time excessive?
16. Is the defrost termination, thermostat (if used) set too high?
17. Are the refrigerant controls incorrectly adjusted?
18. Is the air entering the condenser above design conditions? Are the condenser fins clear of dirt, dust, etc.?
19. Is there a shortage of refrigerant?
20. Has the equipment been modified to use replacements for CFC-12, CFC-502 or other refrigerant? If so, have the modifications been made in accordance with the recommendations of the equipment manufacturer? Is the refrigerator charged with the proper refrigerant and lubricant? Does the system use the recommended compressor?

### Appendix D. - Recommendations to User

- 1.0 Hussmann Corporation provides instructions and recommendations for proper periodic cleaning. The user will be responsible for such cleaning, including the cleaning of low temperature equipment within the compartment and the cooling coil area(s). Cleaning practices, particularly with respect to proper refrigerator unloading and warm-up, must be in accordance with applicable recommendations.
- 1.1 Cleaning of non frozen food equipment should include a weekly cleaning of the food compartment as a minimum to prevent bacteria growth from accumulating. Actual use and products may dictate more frequent cleaning. Circumstances of use and equipment design must also dictate the frequency

## Appendices (Cont'd)

of cleaning the display areas. Weekly washing down of the storage compartment is also recommended, especially for equipment subject to drippage of milk or other liquids, or the collection of vegetable, meat, crumbs, etc. or other debris or litter. Daily cleaning of the external areas surrounding the storage or display compartments with detergent and water will keep the equipment presentable and prevent grime buildup.

- 1.2 Load levels as defined by the manufacturer must be observed.
- 1.3 The best preservation is achieved by following these rules:
  - a) Buy quality products.
  - b) Receive perishables from transit equipment at the ideal temperature for the particular product.
  - c) Expedite perishables to the store's storage equipment to avoid unnecessary warm-up and prolonged temperature recovery. Food store refrigerators are not food chillers nor can they reclaim quality lost through previous mishandling.
  - d) Care must be taken when cross merchandising products to ensure that potentially hazardous vegetable products are not placed in non refrigerated areas.

- e) Display and storage equipment doors should be kept closed during periods of inactivity.
- f) Minimize the transfer time of perishables from storage to display.
- g) Keep meat under refrigeration in meat cutting and processing area except for the few moments it is being handled in processing. When a cut or tray of meat is not to be worked on immediately, the procedure should call for returning it to refrigeration.
- h) Keep tools clean and sanitized. Since mechanical equipment is used for fresh meat processing, all such equipment should be cleaned at least daily and each time a different kind of meat product comes in contact with the tool or equipment.
- i) Make sure that all refrigeration equipment is installed and adjusted in strict accordance with the manufacturer's recommendations.
- j) See that all storage and refrigeration equipment is kept in proper working order by routine maintenance.

For further technical information, please log on to <http://www.husmann.com/products/ISLA.htm>

---

## 10. Service Record

Last service date: By:

_____	_____
_____	_____
_____	_____
_____	_____
_____	_____
_____	_____
_____	_____

---

### **HUSSMANN®**

Additional copies of this publication may be obtained by contacting:  
Hussmann® Chino or going to our website

13770 Ramona Avenue • Chino, California 91710  
(909) 628-8942 FAX  
(909) 590-4910  
(800) 395-9229

Hussmann Corporation  
12999 St. Charles Rock Road  
Bridgeton, MO 63044-2483  
(800) 922-1919

[www.hussmann.com](http://www.hussmann.com)

The *MODEL NAME* and *SERIAL NUMBER* is required in order to provide you with the correct parts and information for your particular unit.

They can be found on a small metal plate on the unit. Please note them below for future reference.

**MODEL:**

**SERIAL NUMBER:**

**HATCO SERIAL No:**