

Portion of parts removed for clarity.

5 door merchandiser shown.



NSF Certification

This merchandiser model is manufactured to meet NSF/ANSI (National Sanitation Foundation) Standard #7 requirements for construction, materials and cleanability.

Performance Data	Page 2	Estimated Shipping Weights	Page 6
Product Data (AHRI Statistics)	Page 2	Shelf Options	Page 6
Cross Section	Page 3	Wiring Diagrams	Page 7
Plan View	Page 4	Computing Refrigeration and Electrical Load	Page 8
Electrical Loads	Page 5	QR Code for Parts and Product Information	Page 8
		Revision History	Page 8

We reserve the right to change or revise specifications and product design in connection with any feature of our products. Such changes do not entitle the buyer to corresponding changes, improvements, additions or replacements for equipment previously sold or shipped.

Data sheet-Insight IRMN

Refrigeration Data ¹

IRMN		Optimal Shelf Life	Energy Comparison
Application		Medium Temperature	AHRI 1200 Rating Point ³
Lit Mullions	Discharge Air °F (°C)	36 (2.2)	37 (2.8)
	Average Evaporator °F (°C) ²	28 (-2.2)	29 (-1.7)
	Unit Sizing °F (°C)	26 (-3.3)	27 (-2.8)
	Parallel Btu/hr/dr (Watts/dr)	487 (143)	468 (137)
	Conventional Btu/hr/dr (Watts/dr)	505 (148)	485 (142)

Notes:

1. All data based on store temperature and humidity that does not exceed NSF Type 1 ambient conditions of 75°F and 55% relative humidity unless otherwise noted.
2. Average evaporator temperature shown. Use dew point for high glide refrigerants for unit sizing. Care should be taken to use the dew point in PT tables for measuring and adjusting superheat. Adjust evaporator pressure as needed to maintain discharge air temperature shown.
3. AHRI 1200 Rating Point for energy comparison only.

Defrost Data

Frequency (hours between defrost)	24
Offtime Time (minutes)	60
Electric Temp Term (°F)	N/A
Failsafe (minutes)	N/A
Gas Duration (minutes)	N/A
Defrost Water ⁴	0.4 lb/dr/day (0.18 kg/dr)

⁴ (± 15% based on case configuration and product loading).

Conventional Controls

Low Pressure Backup Control CI/CO ⁵

+20°F/+10°F

Indoor Unit Only, Pressure Defrost Termination ⁵

Not Recommended

⁵ Use a Temperature Pressure Chart to determine PSIG conversions.

Estimated Charge ⁶

2 dr	1.8 lb	29 oz	0.8 kg
3 dr	2.7 lb	43 oz	1.2 kg
4 dr	3.6 lb	58 oz	1.6 kg
5 dr	4.6 lb	74 oz	2.1 kg

⁶ This is an average for all refrigerant types. Actual refrigerant charge may vary by approximately half a pound.

Product Data

Gross Refrigerated Volume ⁷ (Cu Ft/Dr)	27.93 ft ³ /dr (0.79 m ³ /dr)
AHRI Total Display Area ⁸ (Sq Ft/Dr)	14.30 ft ² /dr (1.33 m ² /dr)
Shelf Area ⁹ (Sq Ft/Dr)	28.68 ft ² /dr (2.66 m ² /dr)

⁷ AHRI Gross Refrigerated Volume: Refrigerated Volume/Unit of Length, ft³/ft [m³/m]

⁸ Computed using AHRI 1200 standard methodology: Total Display Area, ft² [m²]/Unit of Length, ft [m]

⁹ Shelf surface area is composed of bottom deck plus standard shelf complement for this model: (5) rows of 22-in. shelves

Insight Reach-in Multideck Merchandiser,
2, 3, 4 and 5 Door Models



DOE 2017
Energy Efficiency
Compliant

Hussmann refrigerated merchandisers configured for sale for use in the United States meet or surpass the requirements of the DOE 2017 energy efficiency standards.

Typical shelf complement shown:

Five rows of 22-in. shelves spaced equally between bottom display pan and interior top panel.

Optional kits (such as vent fans) add to the overall case height.

4-in. air gap is required between back of case and wall.

Dimensions shown as in. and (mm).

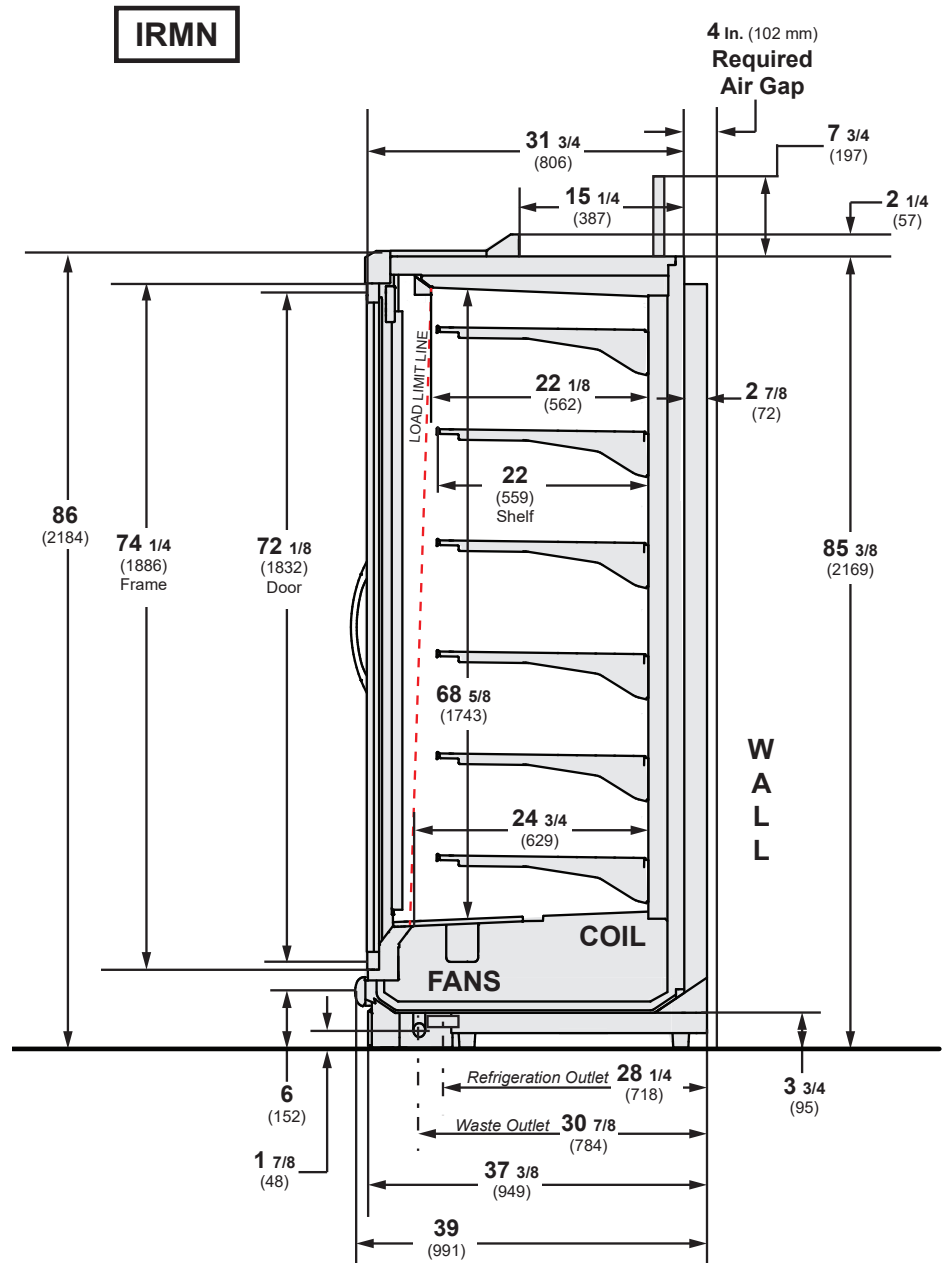

Engineering Plan View

Dimensions shown as in. and (mm).

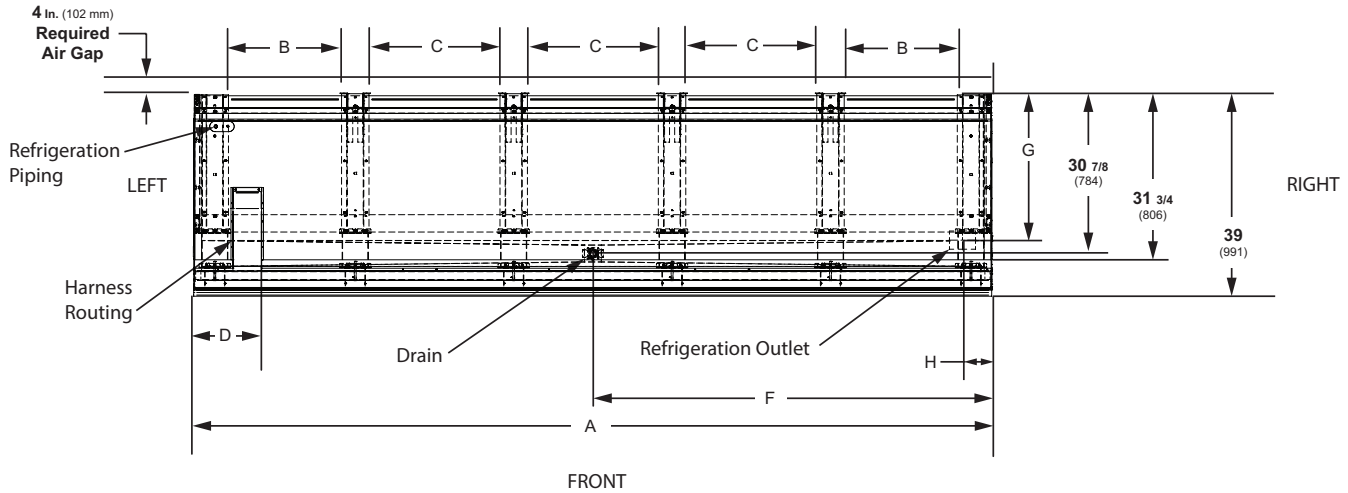

(5 Door Model shown above)

	2 Door	3 Door	4 Door	5 Door
General				
(A) Case Length (without ends or partitions) (Each end and insulated partition adds 2 in. (51 mm) to case line up.)	61 ³ / ₄ (1568)	92 ¹ / ₈ (2340)	122 ⁵ / ₈ (3115)	153 ³ / ₈ (3896)
Maximum O/S dimension of case back to front (includes 2 ⁷ / ₈ for removable electric panel)	39 (991)	39 (991)	39 (991)	39 (991)
Back of case to front of splashguard	37 ³ / ₈ (949)	37 ³ / ₈ (949)	37 ³ / ₈ (949)	37 ³ / ₈ (949)
Width of Skid rail	1 ¹ / ₂ (38)	1 ¹ / ₂ (38)	1 ¹ / ₂ (38)	1 ¹ / ₂ (38)
(B) Distance between edges of external legs and center legs	21 ³ / ₄ (552)	21 ³ / ₄ (552)	21 ³ / ₄ (552)	21 ³ / ₄ (552)
(C) Distance between edges of center legs	N/A	25 ¹ / ₈ (638)	25 ¹ / ₈ (638)	25 ¹ / ₈ (638)
Distance between front legs and splashguard	2 ¹ / ₄ (57)	2 ¹ / ₄ (57)	2 ¹ / ₄ (57)	2 ¹ / ₄ (57)
Electrical Service (Field Electrical Wiring Connection)				
(D) LH End of case to RH of Field Electrical/Control Panel	13 ³ / ₈ (340)	13 ³ / ₈ (340)	13 ³ / ₈ (340)	13 ³ / ₈ (340)
Length of electrical/control panel	61 ³ / ₄ (1568)	92 (2337)	122 ⁵ / ₈ (3115)	153 (3886)
(E) RH end of case to LH end of electrical/Control Panel	145 ⁷ / ₈ (3705)	145 ⁷ / ₈ (3705)	145 ⁷ / ₈ (3705)	145 ⁷ / ₈ (3705)
Waste Outlets				
(F) RH End of case to the center of waste outlet	23 ³ / ₈ (594)	54 ¹ / ₈ (1375)	46 ¹ / ₈ (1172)	76 ⁵ / ₈ (1946)
Back O/S of case to center of waste outlet(s)	30 ⁷ / ₈ (784)	30 ⁷ / ₈ (784)	30 ⁷ / ₈ (784)	30 ⁷ / ₈ (784)
Schedule 40 PVC drip pipe	1 ³ / ₈ (35)	1 ³ / ₈ (35)	1 ³ / ₈ (35)	1 ³ / ₈ (35)
Refrigeration Outlet				
(G) Back of case to center of refrigeration outlet	28 ¹ / ₄ (718)	28 ¹ / ₄ (718)	28 ¹ / ₄ (718)	28 ¹ / ₄ (718)
(H) End of case to center of refrigeration outlet	5 ⁵ / ₈ (143)	5 ⁵ / ₈ (143)	5 ⁵ / ₈ (143)	5 ⁵ / ₈ (143)

Electrical Data

Number of Fans		2 dr	3 dr	4 dr	5 dr				
8-in (200 mm).		2	3	4	5				
						Amperes			
		2 dr	3 dr	4 dr	5 dr	2 dr	3 dr	4 dr	5 dr
Evaporator Fan									
120V 50/60Hz Energy Efficient		0.60	0.90	1.20	1.50	36	54	72	90
240V 50/60Hz Energy Efficient Export		0.30	0.45	0.60	0.75	36	54	72	90
Frame Anti-Sweat Heaters (on fan circuit)									
120V 50/60Hz		0.20	0.30	0.40	0.50	24.1	36.1	48.1	60.2
240V 50/60Hz Export		0.10	0.15	0.20	0.25	24.1	36.1	48.1	60.2

Lighting

Only lighting configurations that are compliant with the U.S. Dept. of Energy (DOE) 2017 regulation are available for sale for use in the U.S.A.

		Amperes				Watts			
		2 dr	3 dr	4 dr	5 dr	2 dr	3 dr	4 dr	5 dr
LED LIGHTING									
Standard Vertical LED Lighting (24V)									
120V		0.35	0.53	0.71	0.89	42.5	63.8	85.1	106.4
220V		0.19	0.29	0.39	0.48	42.5	63.8	85.1	106.4
Minimum Circuit Ampacity (fans, lights & A.S.)									
120V 50/60Hz		1.44	2.16	2.95	3.61				
240V 50/60Hz Export		0.74	1.11	1.49	1.54				
Maximum Over Current Protection 120V		20	20	20	20				
Maximum Over Current Protection 240V		15	15	15	15				

ENDS or PARTITIONS

Each standard end and each insulated partition adds 1 1/2 in. (38 mm) to case line up. Optional view end with end bumper adds 3 3/4 in. (95 mm).

PHYSICAL DATA

Merchandiser Drip Pipe (in.)	1 1/4
Schedule 40 PVC	
Merchandiser Liquid Line (in.)	3/8
Merchandiser Suction Line (in.)	5/8

ESTIMATED SHIPPING WEIGHT †

Case	2 Door	3 Door	4 Door	5 Door	Solid End (each)
lb (kg)	1026 (465)	1440 (653)	1837 (833)	2256 (1023)	60 (27)

† Actual weights will vary according to optional kits included.

Shelf Options

Approved shelf sizes for standard (horizontal, 2-3 position brackets) displays:

- 18-inch
- 20-inch
- 22-inch
- 24-inch

Contact engineering for non-standard (4 position brackets or other) display recommendations.

Minimum number of Shelves: 4

Optimal number of Shelves: 5

Maximum number of Shelves: 8

Maximum number of Lighted Shelves: 0

Standard shelf complement for test purposes: (5) rows of 22-in. shelves evenly distributed vertically.

COMPLETE CASE WIRING

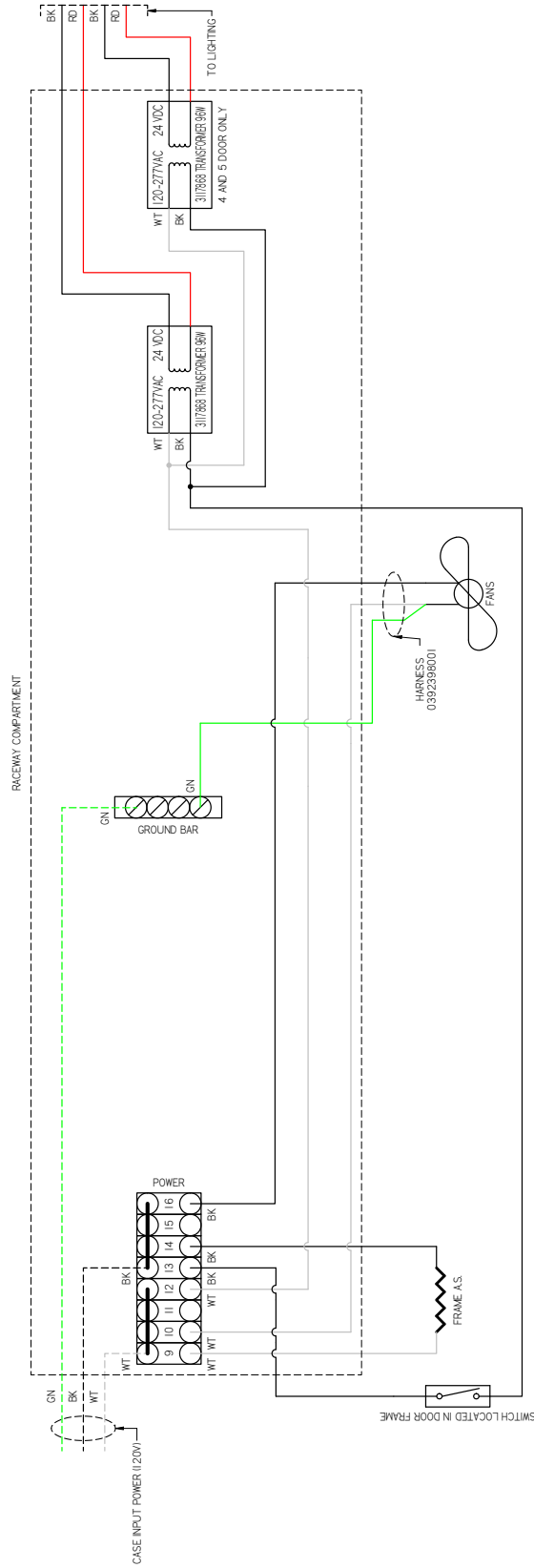

3159488_B

UL COLOR CODES / ABBREVIATIONS

RED - RD	WHITE - WT
BLACK - BK	GREEN - GN
BLUE - BL	BROWN - BN
YELLOW - YL	ORANGE - OR
GRAY - GR	VIOLET - VT

FACTORY / KGA WIRE

FACTORY LOGGA WIRE
FIELD WIRE

- NOTES:
1. PRINTED DOCUMENT REQUIRED. SETTING ALL COLORS BLACK & WHITE
 2. ALL WIRES 18 AWG UNLESS OTHERWISE NOTED
 3. IRI - ABBREVIATION FOR INSIGHT REACH IN
 4. DARK BLACK LINES IN TERMINAL BLOCKS REPRESENT REMOVABLE JUMPERS
 5. LED POWER SUPPLIES ARE LOCATED ON SEPARATE COMPONENT TRAY IN RACEWAY
 - 5.1. LED POWER SUPPLY TRAY IS LOCATED ON SEPARATE DOOR MODULE BOM
 - 5.2. LED POWER SUPPLY TRAY IS TO BE INSTALLED IN DOOR FRAME AREA
 - 5.3. FINAL ELECTRICAL CONNECTIONS TO BE MADE AFTER DOOR FRAME IS ATTACHED TO CASE

Estimating Refrigeration and Electrical Load (for comparison purposes only)

Case Btu

To determine Btu for a case, refer to the performance data chart on Page 2. Select the type of remote refrigeration system (parallel or conventional), which will give Btu/hr/dr. Multiply this number by the total number of doors to determine Btu per hour.

Case Electrical

Refer to store legend to determine number of circuits. Lighting should be specified in store legend.

Fan electrical load for a case is computed by selecting the case model and fan voltage on Page 5. For example, a 4 door case uses 4 fans. In this instance, fans use 1.20 Amps, lights use 0.71 Amps and the anti-sweat heaters use 0.4 Amps. The MCA listed on page 5 includes the fans, lights and anti-sweat heaters.

Line Sizing — Refer to store legend.

Hussmann Line Sizing Charts are engineered for use with Hussmann refrigeration equipment.



Scan the QR code with your mobile device to access additional product information or order parts.

Parts may also be ordered at:

parts.hussmann.com

Call toll free: 1.855.487.7778

Revision History

Revision A: April 2023: Original Issue

Revision B: May 2023: Updated revision letter.

Revision C: February 2024: Updated circuit ampacity

Revision D: May 2024: Updated Defrost Data