

HUSSMANN®

FNGSC-A

SELF-CONTAINED MERCHANDISER

EVOLVE™

R-290



FNGSC-A

DUAL TEMPERATURE SELF-CONTAINED MERCHANDISER



ADVANTAGES

- Environmentally-friendly R-290 natural refrigerant that has a low Global Warming Potential (GWP) of 3
- Set-point change allows for low or medium temperature operation for maximum flexibility
- Self-service design with 7" straight glass sides drastically increase product visibility and shopability



KEY FEATURES

- Plug and play design for easy installation and movement in the event of planogram changes
- Easy to service with slide out air-cooled condensing unit
- Available in 4, 6, and 8-foot lengths



FNGSC6A



1.800.592.2060



www.husmann.com

FNGSC-A Self-Contained Merchandiser

SPECIFICATIONS

Model	FNGSC4A, FNGSC6A, FNGSC8A
Defrost	hot gas
Power Connection	5-20P (one plug on 4' and 6' and two plugs on 8')
Refrigerant	R-290 (propane)
Supply Power	120 VAC / 1 phase / 60 Hz

Model	Approx. Weight
FNGSC4A	582 lb (264 kg)
FNGSC6A	746 lb (338 kg)
FNGSC8A	918 lb (416 kg)

AVAILABLE OPTIONS

- Exterior color
- Bumper color
- Casters

TECHNICAL INFORMATION



Scan or click QR to access additional resources at hussmann.com

Available in 4, 6, and 8-foot lengths.

DIMENSIONS

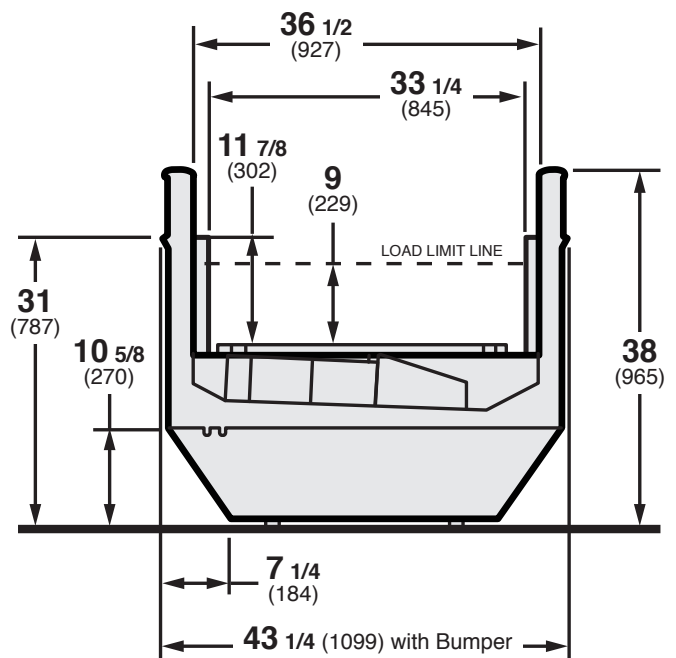

Model	FNGSC4A	FNGSC6A	FNGSC8A
Length	52 7/8 (1,343)	78 7/8 (2,003)	102 7/8 (2,613)

NOTE Dimensions are in Inches (millimeters)

NOTE: Use Hussmann's technical data sheets to get dimensions for all store layout purposes.

NOTE: These merchandisers are designed for use in stores when temperature and humidity do not exceed 75° F (23.9° C) and 55% R.H.

We reserve the right to change or revise specifications and product design in connection with any feature of our products. Such changes do not entitle the buyer to corresponding changes, improvements, additions, or replacements for equipment previously sold or shipped. For additional resources, contact your representative or visit www.hussmann.com.

©2024 Hussmann Corporation

HUSSMANN®

Hussmann Corporation
12999 St. Charles Rock Rd.
Bridgeton, MO 63044-2483
Ph: 1.800.592.2060

www.hussmann.com

PS_FNGSC-A_0000313_C_EN