

8-foot merchandiser shown. Portion of parts removed for clarity.

*Coils, fans and condensing units are modular with one per 3 or 4 foot section.

Certifications



UL EPH Certification

This merchandiser model is manufactured to meet ANSI/SCC Standards requirements for construction, materials, and cleanability.

This case is intended for NSF 2 ambient applications (80°F / 55% RH).

⚠ WARNING

Component parts shall be replaced with like components, and servicing shall be done by factory authorized service personnel only, so as to minimize the risk of possible ignition due to incorrect parts or improper service.

Technical Data Sheet

ID6SU-W

Self-Contained Water-Cooled R-290 Merchandiser, Doored

Applications

Beverage, Dairy, Deli, Meat, Produce

P/N 3080594 Rev L

October 2024

Models Covered:

ID6SU4W, ID6SU6W,
ID6SU8W, ID6SU12W

Table of Contents

Performance Data	2
Cross-Section View	3
Plan View	4
Electrical Specifications	6
Shipping Weight	7
Wiring Diagram(s)	8

IMPORTANT

**DRAIN EXTENSION KIT
REQUIRED TO PIPE MULTIPLE
CASES TO ONE DRAIN OR TO
USE A RAISED HUB DRAIN**

Insight standard field electrical connections are at the top left of the merchandiser

We reserve the right to change or revise specifications and product design in connection with any feature of our products. Such changes do not entitle the buyer to corresponding changes, improvements, additions or replacements for equipment previously sold or shipped.

Insight ID6SU-W
Dairy / Deli / Beverage /
Produce / Meat

Refrigeration Data ^{1}**

ID6SU-W		Optimal Shelf Life 4,8,12 ft		Optimal Shelf Life 6 ft	
Application		Dairy/Deli/ Beverage/ Produce	Convertible / Meat	Dairy/Deli/ Beverage/ Produce	Convertible / Meat
Unlit Shelves	Discharge Air °F (°C)	30 (-1.11)	28 (-2.22)	30 (-1.11)	30 (-1.11)
	Deadband	8	8	8	8
Lit Shelves	Discharge Air °F (°C)	30 (-1.11)	28 (-2.22)	30 (-1.11)	30 (-1.11)
	Deadband	8	8	8	8
Fan Speed ²		1500	1500	1600	1600

Notes:

1. All data based on store temperature and humidity that does not exceed NSF Type 1 ambient conditions of 75°F and 55% relative humidity except where noted.
2. Some lengths and/or applications require optional fan motor kits applied by the Hussmann Product Configurator (HPC) .
3. Water supply design conditions are 41°F to 118°F (5°C to 48°C).
4. Reduce refrigeration load by 15%, if fitted with CaseShieldPTM.

Compressor Data

Total Heat of Rejection⁵

	BTU/Hr
4 ft	13,150
6 ft	20,584
8 ft	26,300
12 ft	39,449

⁵ THR listed for maximum design conditions. Normal operating loads may be lower

Cooling Water

Pressure Drop ⁷

	PSI
4 Ft	3.0
6 Ft	9.0
8 Ft	9.0
12 Ft	10.0

Cooling Water Design TD

10°F

⁷ Auto-Balancing Valve requires a minimum of 2 PSI to operate. Subtract 2 PSI if the Auto-Balancing Valve is not supplied.

Glycol/Water Flow Rate ⁸

	GPM	LPM
4 ft	3.0	7.6
6 ft	6.0	15.1
8 ft	6.0	15.1
12 ft	8.0	22.7

⁸ Use a pre-mixed inhibited glycol solution. If the mixing is to be done on site, use only distilled or de-ionized water (do not use city water).

Defrost Data

Frequency (hours between defrost)	4
Defrost Water ⁶	10.3 lb/ft/day (15.3 kg/m)

⁶ (± 15% based on case configuration and product loading).

OFFTIME	ID6SU-W
Time (minutes)	20

ELECTRIC OR GAS Not Available

Charge per unit ⁹

4 ft	0.33 lb	5.3 oz	150 g
6 ft	0.33 lb	5.3 oz	150 g
8 ft	0.33 lb	5.3 oz	150 g
12 ft	0.33 lb	5.3 oz	150 g

⁹ Maximum R-290 charge per condensing unit = 150 g.

Product Data

Gross Refrigerated Volume ¹⁰ (Cu Ft/Ft)	13.2 ft ³ /ft (1.23 m ³ /m)
AHRI Total Display Area ¹¹ (Sq Ft/Ft)	5.55 ft ² /ft (1.69 m ² /m)
Shelf Area ¹² (Sq Ft/Ft)	11.69 ft ² /ft (3.56 m ² /m)

¹⁰ AHRI Gross Refrigerated Volume: Refrigerated Volume/Unit of Length, ft³/ft [m³/m]

¹¹ Computed using AHRI 1200 standard methodology: Total Display Area, ft² [m²]/Unit of Length, ft [m]

¹² Shelf surface area is composed of bottom deck plus standard shelf complement for this model: (5) rows of 22-in. shelves

Insight Multideck Merchandiser, 6 Display Levels,
Standard Bottom, Ultra Low Front, Water-cooled,
Self-Contained R-290 Propane

Insight ID6SU-W
Dairy / Deli / Beverage /
Produce / Meat

DOE 2017
Energy Efficiency
Compliant

Hussmann refrigerated merchandisers configured for sale for use in the United States meet or surpass the requirements of the DOE 2017 energy efficiency standards.

Dimensions shown as in. and (mm).

Other optional kits may add to the overall case height.

A minimum 1 1/2-in. clearance required to remove raceway cover, 6 1/2-in. for full access. See the Installation manual for instructions.

4-in. between back to back cases.

Shelf complement shown as tested:
Five rows of 22-in. shelves spaced equally between bottom display pan and interior top panel.

Shown with Ellipse Option Canopy and Bumper.

ID6SU-W

2 In. (51 mm)
Required
Air Gap

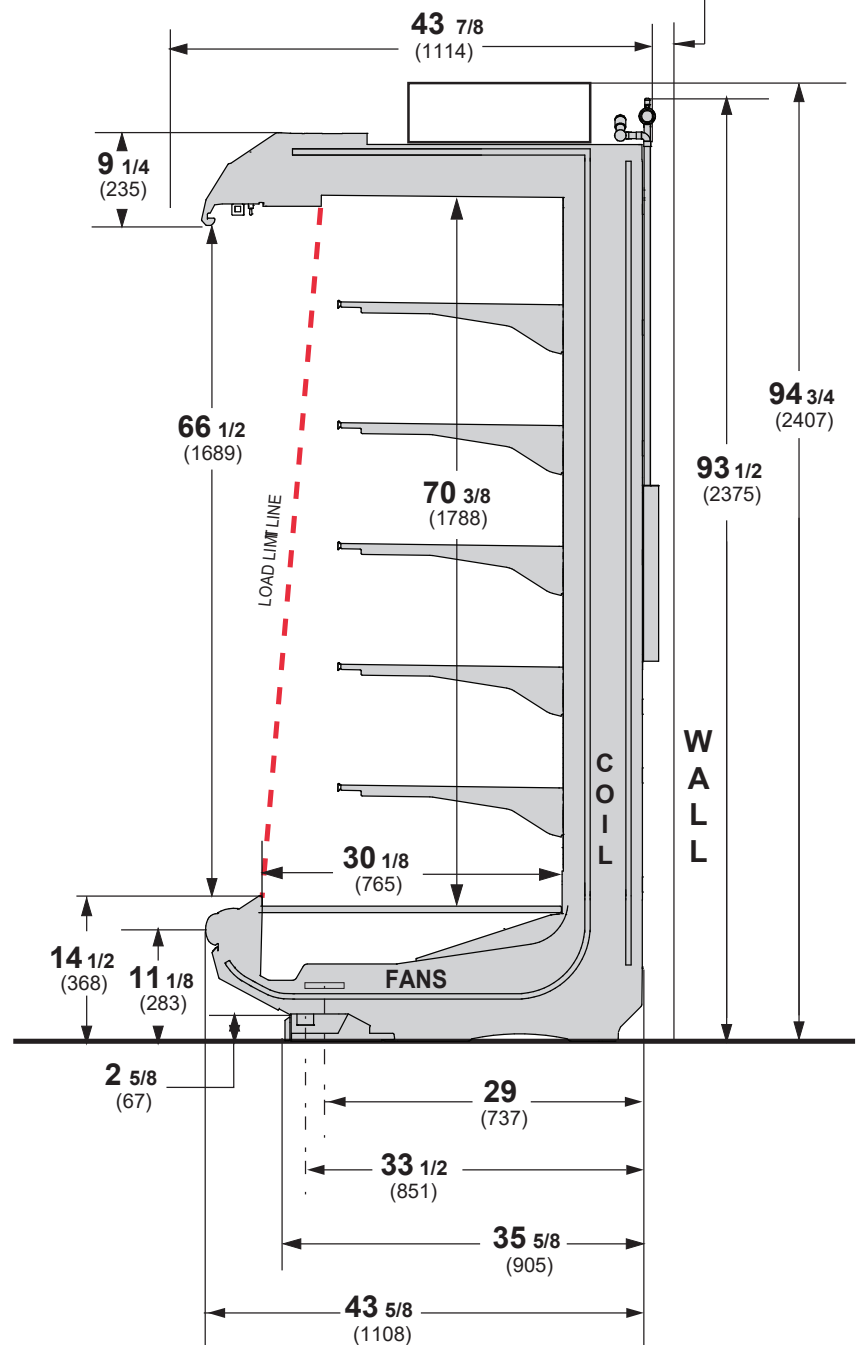

Engineering Plan View

**WARNING: Floor Drain must be located within 24 inches of Waste Outlet.
See page 5 for Drain Extension Option
(must be used with hub-style floor drains).**

Dimensions shown as in. and (mm).

ID6SU-W

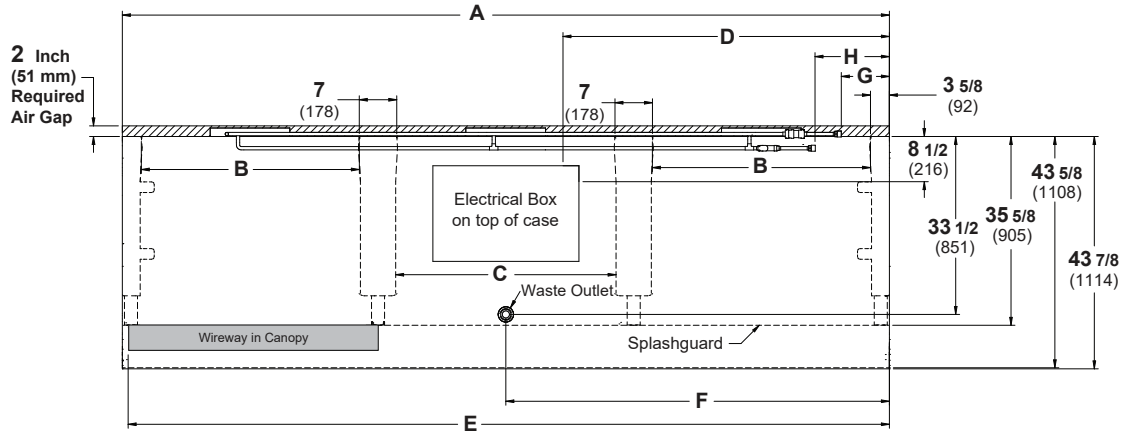

FRONT

(12 Foot Model shown above)

	4 ft	6 ft	8 ft	12 ft
General				
(A) Case Length (without ends or partitions) (Each end and insulated partition adds 1 1/2 in. (38 mm) to case line up.)	48 1/8 (1222)	72 1/4 (1835)	96 1/4 (2445)	144 3/8 (3668)
Maximum O/S dimension of case back to front (includes bumper)	43 1/2 (1105)	43 1/2 (1105)	43 1/2 (1105)	43 1/2 (1105)
Back of case to front of splashguard	35 1/2 (902)	35 1/2 (902)	35 1/2 (902)	35 1/2 (902)
(B) Distance between edges of external legs and center legs	NA	29 (737)	41 (1041)	41 (1041)
(C) Distance between edges of center legs	41 1/8 (1045)	NA	NA	41 1/8 (1045)
Distance between front legs and splashguard	8 (203)	8 (203)	8 (203)	8 (203)
Electrical Service (Field Electrical Wiring Connection)				
(D) RH End of case to center of Field Electrical Wiring Connection (top of case)	11 (279)	9 (229)	13 1/2 (343)	61 1/2 (1562)
Back of case to center of Field Electrical Wiring Connection	8 1/2 (216)	8 1/2 (216)	8 1/2 (216)	8 1/2 (216)
Length of electrical wireway	44 5/8 (1133)	33 1/2 (851)	45 7/8 (1165)	45 7/8 (1165)
(E) RH end of case to LH end of electrical wireway (top of case)	46 1/2 (1181)	70 1/2 (1791)	94 1/2 (2400)	142 5/8 (3630)
Waste Outlets (see page 5 for drain extension option)				
(F) RH End of case to the center of waste outlet	24 1/8 (613)	24 1/8 (613)	24 1/8 (613)	72 1/4 (1835)
Back O/S of case to center of waste outlet(s)	33 1/2 (851)	33 1/2 (851)	33 1/2 (851)	33 1/2 (851)
Schedule 40 PVC drip pipe	1 1/4 (32)	1 1/4 (32)	1 1/4 (32)	1 1/4 (32)
<i>Floor Drain must be located within 24 inches of Waste Outlet.</i>				
Refrigeration Outlet				
(G) RH End of case to glycol/water outlet	4 3/8 (111)	3 1/4 (83)	9 (229)	9 (229)
(H) RH End of case to glycol/water inlet	9 (229)	7 7/8 (200)	14 (356)	14 (356)

Engineering Plan View

Insight ID6SU-W
Dairy / Deli / Beverage /
Produce / Meat

Waste Outlet Drain Extension Option

Dimensions shown as in. and (mm).

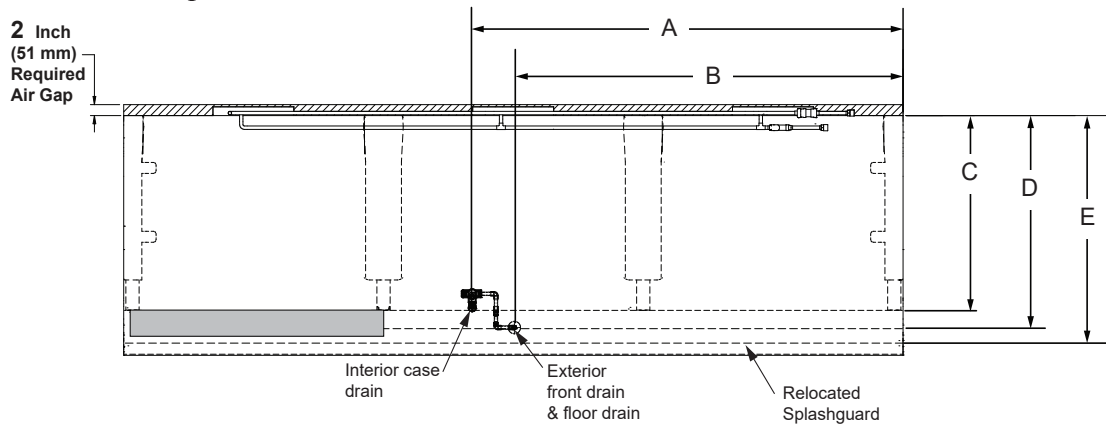

FRONT

(12 Foot Model shown above)

	4 ft	6 ft	8 ft	12 ft
Waste Outlet Drain Option				
(A) RH of case to center of interior case drain	24 1/8 (613)	24 1/8 (613)	24 1/8 (613)	72 1/4 (1835)
(B) RH of case to center of exterior front drain and floor drain* *Drain extension shown piped to the right but may be either direction	13 3/4 (349)	13 3/4 (349)	13 3/4 (349)	61 7/8 (1572)
(C) Back of case to center of original waste outlet	33 1/2 (851)	33 1/2 (851)	33 1/2 (851)	33 1/2 (851)
(D) Back of case to center of relocated waste outlet (with drain extension kit)	38 1/4 (972)	38 1/4 (972)	38 1/4 (972)	38 1/4 (972)
(E) Back of case to the back of the relocated splashguard (with drain extension kit)	41 (1041)	41 (1041)	41 (1041)	41 (1041)

Partial End View

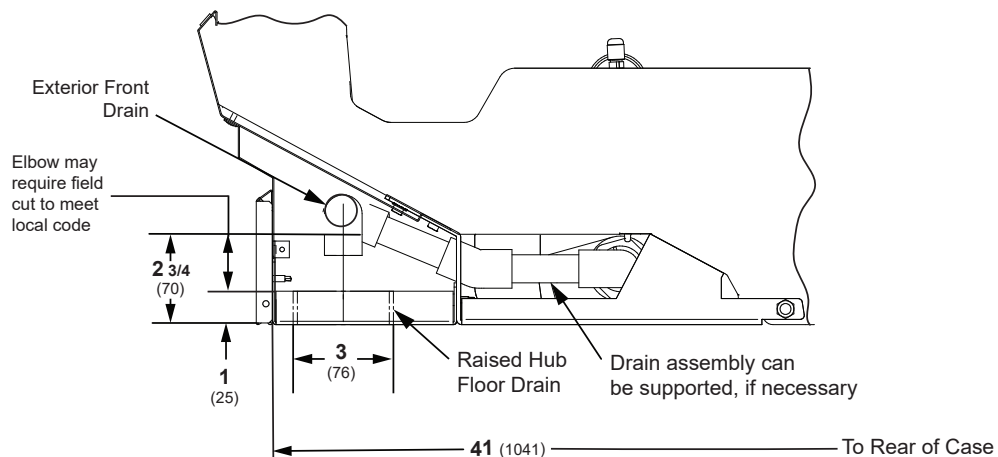

IMPORTANT:
DRAIN EXTENSION KIT REQUIRED TO PIPE MULTIPLE CASES TO ONE DRAIN OR TO USE A RAISED HUB DRAIN

IMPORTANT: If the hub drain is used instead of a flush floor sink, a drain extension kit must be installed. Hub drains must be located in front of the waste outlet because of the required air gap.

Insight ID6SU-W
 Dairy / Deli / Beverage /
 Produce / Meat

Electrical Data

Number of Fans	4 ft	6 ft	8 ft	12 ft
10.3-in.	1	2	2	3

Evaporator Fan	Amperes				Watts			
	4 ft	6 ft	8 ft	12 ft	4 ft	6 ft	8 ft	12 ft
120V 60Hz Energy Efficient	0.40	0.80	0.80	1.20	24	48	48	72

Condensing Unit (208V, 3 Ph, 60Hz) Standard

NOTE: One compressor can start at a time.

Compressor RLA	4.5	9.0	9.0	13.5
Compressor LRA	58/unit	58/unit	58/unit	58/unit

Merchandiser Circuit Requirements (208V, 3 Ph, 60 Hz)

Total Amps	5.3	10.2	10.6	15.9
MCA	6.6	12.7	13.2	19.9
Maximum Over Current Protection	20	20	20	20



NEMA Plug L21-20 (All lengths)

Lighting

ONLY LIGHTING CONFIGURATIONS THAT ARE COMPLIANT WITH THE U.S. DEPT. OF ENERGY (DOE) 2017 REGULATION ARE AVAILABLE FOR SALE FOR USE IN THE U.S.A.

	Amperes				Watts			
	4 ft	6 ft	8 ft	12 ft	4 ft	6 ft	8 ft	12 ft
STANDARD LED LIGHTING								
LED Canopy Lights								
1 Row	0.16	0.22	0.31	0.47	19	27	38	57
OPTIONAL LED LIGHTING								
2 Rows of Canopy Lights	0.32	0.44	0.62	0.94	38	54	76	114
LED SHELF LIGHTING								
1 Row of Shelves	0.06	0.07	0.11	0.17	7	9	13	20
2 Rows of Shelves	0.11	0.15	0.22	0.33	13	18	27	40
3 Rows of Shelves	0.17	0.22	0.33	0.50	20	27	40	60
4 Rows of Shelves	0.22	0.30	0.44	0.67	27	36	53	80
5 Rows of Shelves	0.28	0.37	0.56	0.83	33	44	67	100
6 Rows of Shelves	0.33	0.44	0.67	1.00	40	53	80	120
7 Rows of Shelves	0.39	0.51	0.78	1.17	47	62	93	140
LED Rail Light								
1 Row	0.06	0.07	0.11	0.17	7	9	13	20

120V Lighting Circuit Total = Standard Lighting + Total Optional Lighting + Optional Shelf Lighting
 230V Lighting Circuit Total = Multiply 120V Lighting Circuit Total by 0.52

ENDS or PARTITIONS

Each standard end and each insulated partition adds 1 1/2 in. (38 mm) to case line up. Optional view end with end bumper adds 3 3/4 in. (95 mm).

PHYSICAL DATA

Merchandiser Drip Pipe (in.) 1 1/4
 Schedule 40 PVC

ESTIMATED SHIPPING WEIGHT †

Case					Solid End
	4 ft	6 ft	8 ft	12 ft	(each)
lb (kg)	950 (431)	1200 (544)	1400 (635)	1850 (839)	100 (45)

† Actual weights will vary according to optional kits included.

Shelf Options

Approved shelf sizes for standard (horizontal, 2-3 position brackets) displays:

- 18-inch
- 20-inch
- 22-inch
- 24-inch

Contact engineering for non-standard (4 position brackets or other) display recommendations.

Minimum number of Shelves: 4

Optimal number of Shelves: 5

Maximum number of Shelves: 7

Maximum number of Lighted Shelves: 7

Standard shelf complement for test purposes: (5) rows of 22-in. shelves evenly distributed vertically.

Insight ID6SU-W
 Dairy / Deli / Beverage /
 Produce / Meat

Fan Wiring
Offtime Defrost

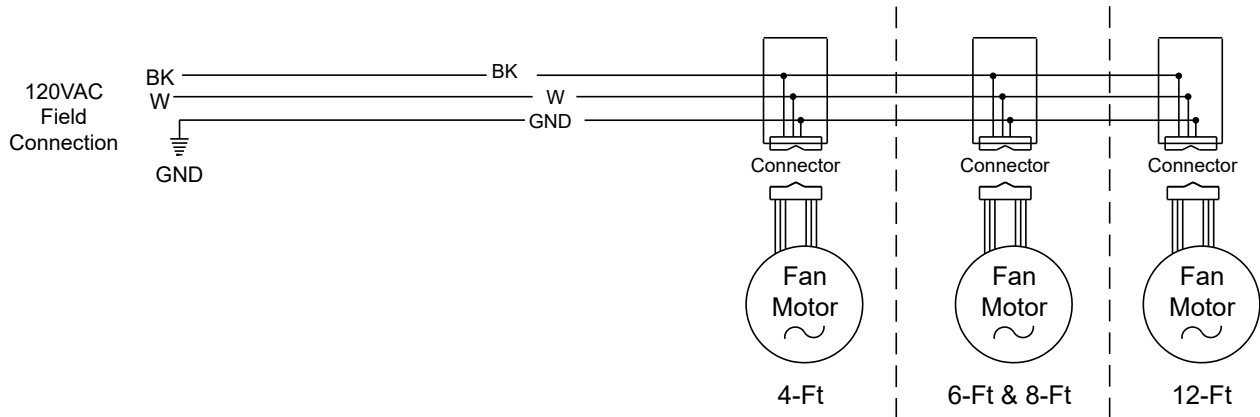

LED Canopy Light Circuits

LED Canopy Lighting - 2 Rows

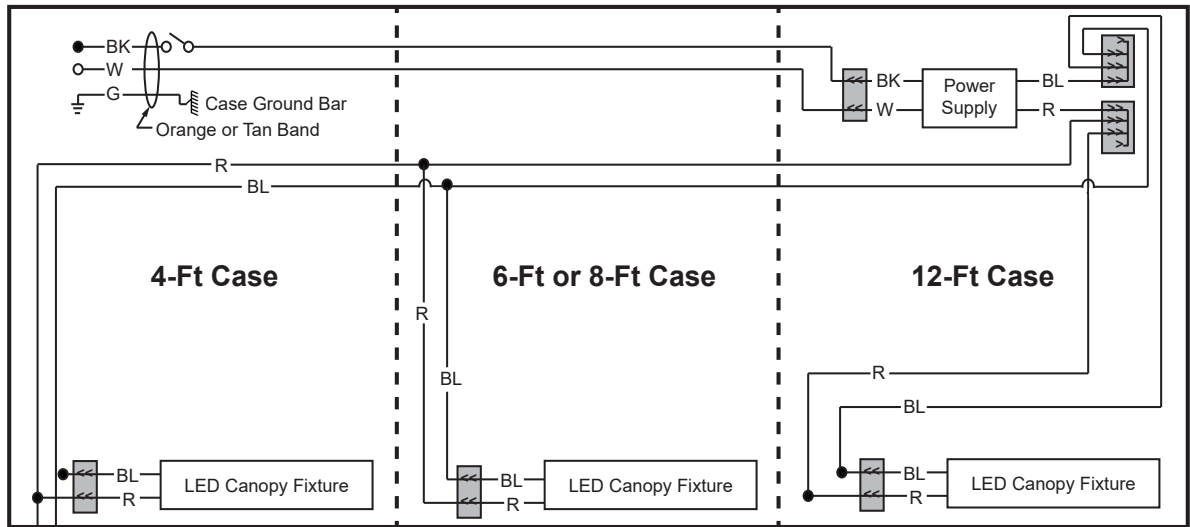

Optional LED Lighting - LED Rail - 1 Row

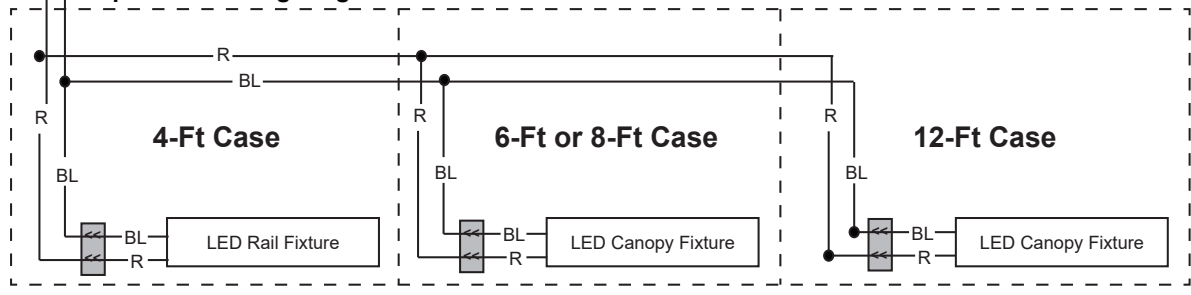

WARNING

All components must have mechanical ground, and the merchandiser must be grounded.

R = Red Y = Yellow G = Green BL = Blue BK = Black W = White
 ● = 120V POWER ○ = 120V NEUTRAL ⚡ = FIELD GROUND ⏏ = CASE GROUND

Optional LED Shelf Lighting

Insight ID6SU-W
Dairy / Deli / Beverage /
Produce / Meat

Shelf Harness and LED Light Circuits for 4 or 5 Rows of Shelves

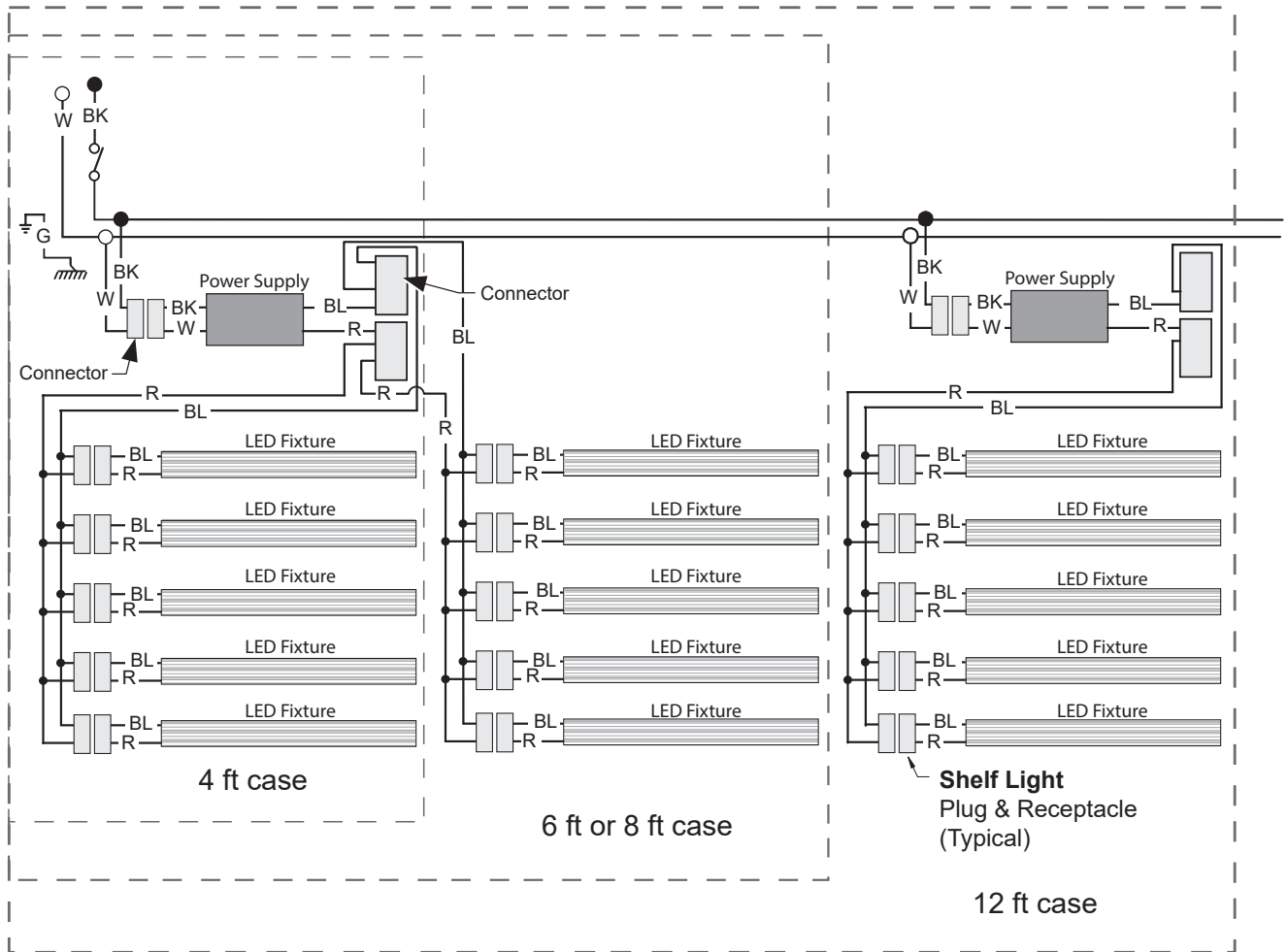

WARNING

All components must have mechanical ground, and the merchandiser must be grounded.

R = Red Y = Yellow G = Green BL = Blue BK = Black W = White
 ● = 120V POWER ○ = 120V NEUTRAL ⊥ = FIELD GROUND ≡ = CASE GROUND

Shelf Harness and LED Light Circuits for 6 or 7 Rows of Shelves

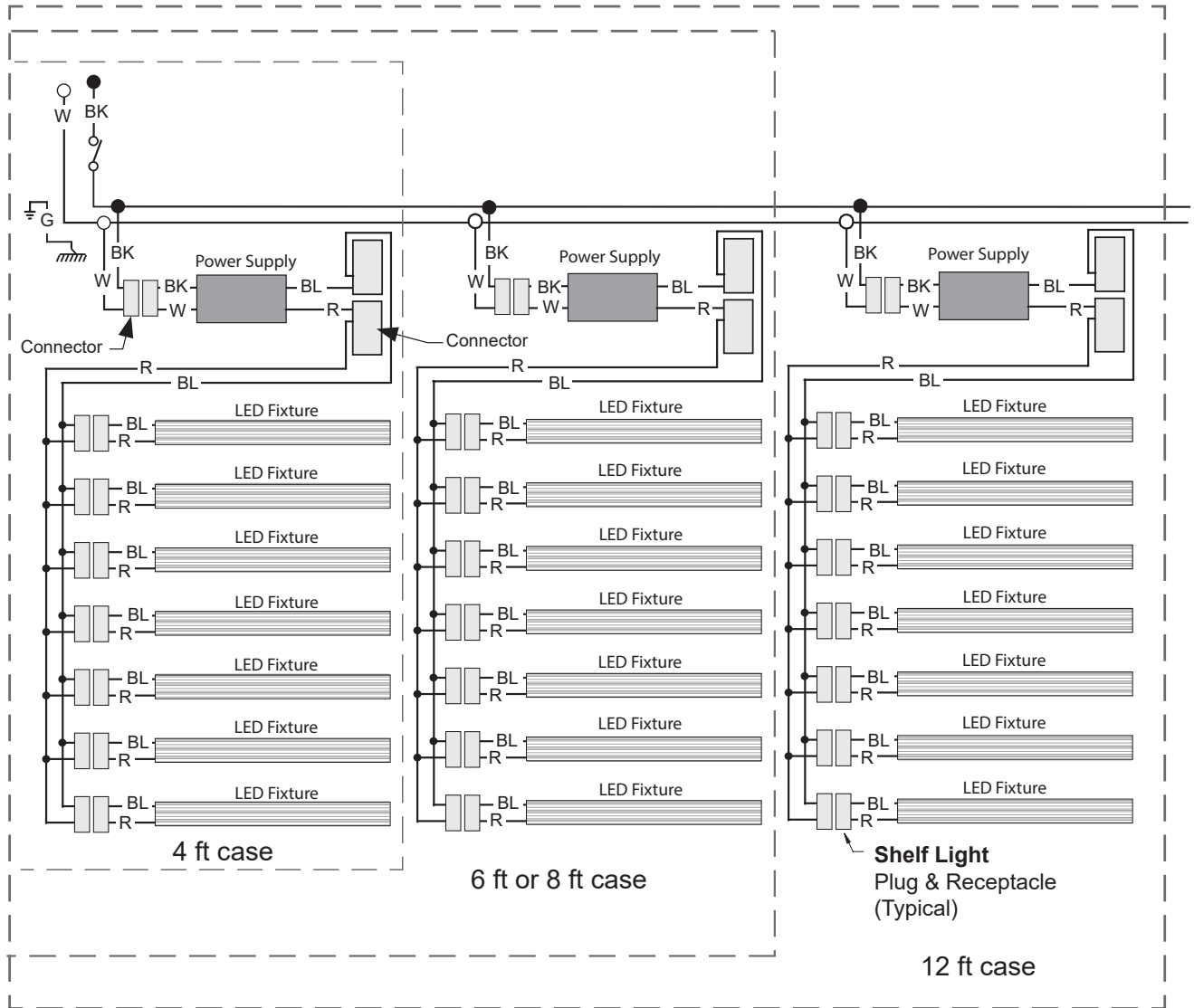

WARNING

All components must have mechanical ground, and the merchandiser must be grounded.

- R = Red Y = Yellow G = Green BL = Blue BK = Black W = White
- = 120V POWER ○ = 120V NEUTRAL ⊥ = FIELD GROUND ≡ = CASE GROUND

CoreLink Propane Wiring Diagram

Insight **ID6SU-W**
Dairy / Deli / Beverage /
Produce / Meat

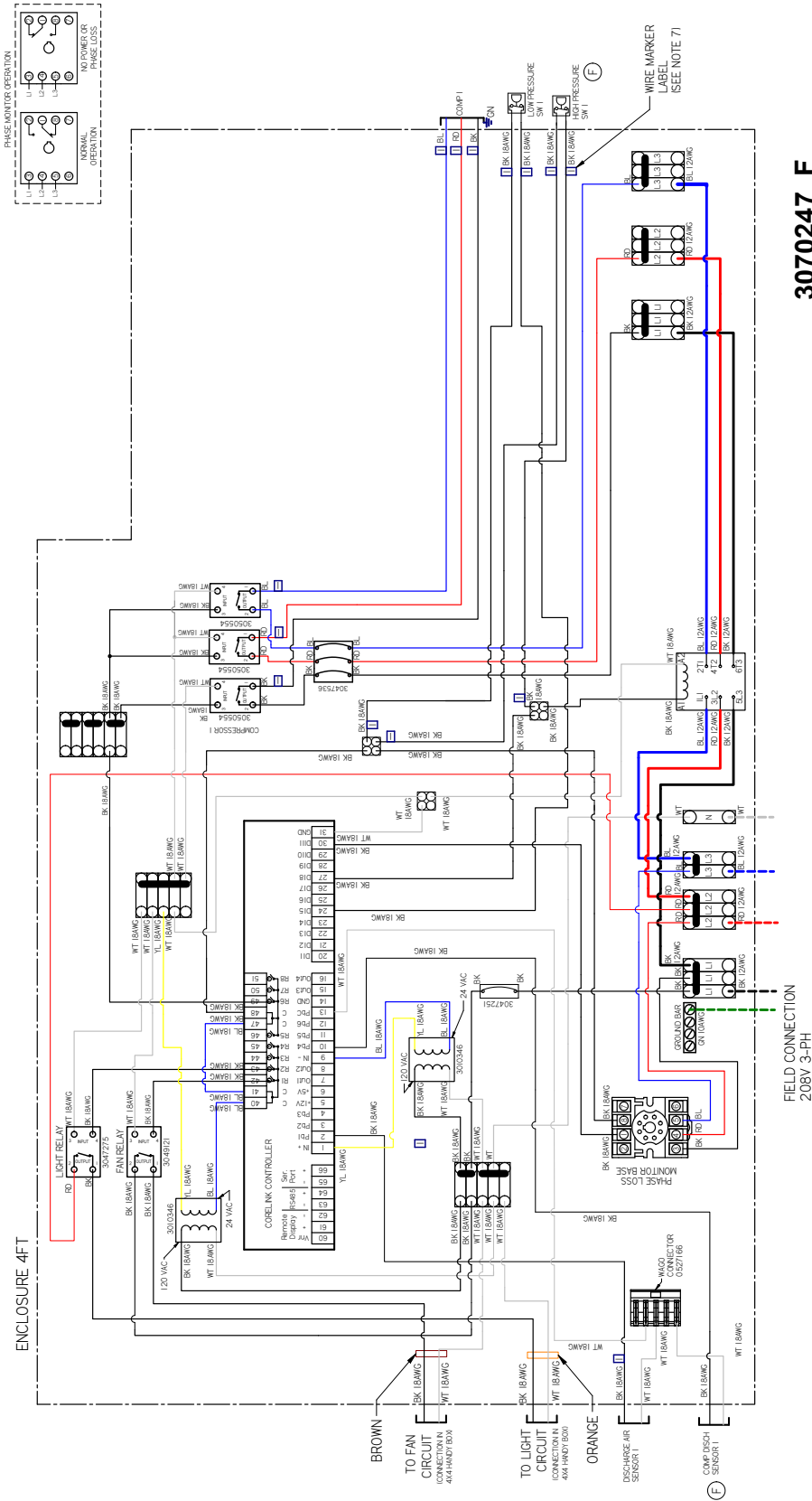

3070247_F

- UL COLOR CODES / ABBREVIATIONS**
- WHITE = WT
 - BLACK = BK
 - RED = RD
 - BLUE = BL
 - YELLOW = YL
 - GRAY = GT
 - GREEN = GN
 - ORANGE = OR
 - VIOLET = VT

- FACTORY 14GA WIRE**
- FACTORY 12GA WIRE**
- FIELD WIRE**

- NOTES**
1. APPLICABLE STANDARDS / SPECIFICATIONS
ASME Y14.5M-1994. DIMENSIONS AND TOLERANCES
 2. KEY PRODUCT CHARACTERISTICS PER EPR-0006 & IDENTIFIED WITH SYMBOL
 3. FAN AND LIGHT CIRCUITS TO BE FACTORY MADE CONNECTIONS.
 4. ALL WIRE 14G UNLESS OTHERWISE NOTED.
 5. MATERIAL - N/A
 6. REF 3047407
 7. APPLY WIRE MARKER LABELS TO BOTH END OF SENSOR AND COMPRESSOR WIRES THROUGH WIRES.
 8. PRINTED DOCUMENT REQUIRED SETTING. ALL COLORS BLACK & WHITE.

CoreLink Propane Wiring Diagram

Insight ID6SU-W
Dairy / Deli / Beverage /
Produce / Meat

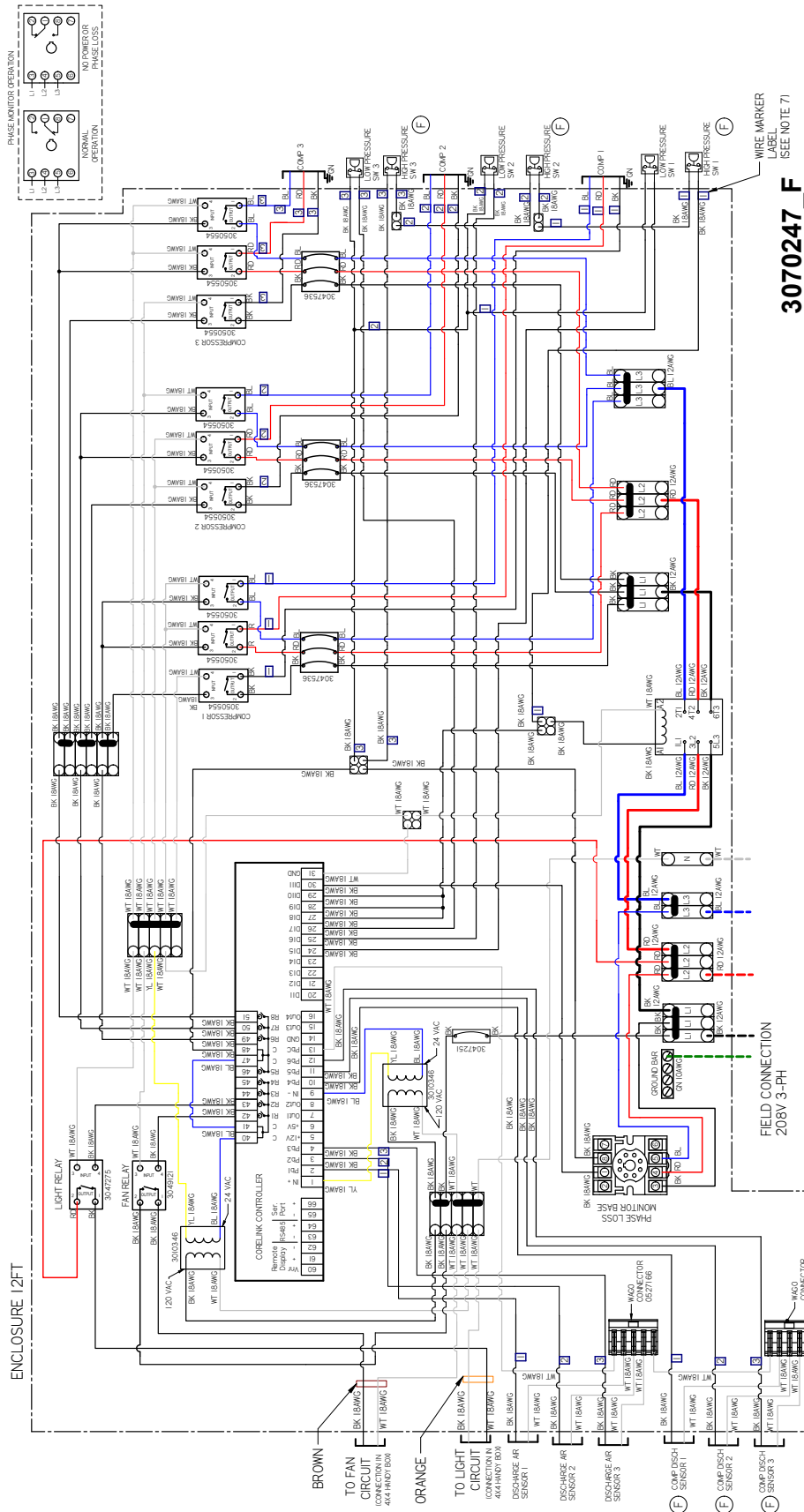

Insight ID6SU-W
Dairy / Deli / Beverage /
Produce / Meat



Scan the QR code with your mobile device to access additional product information or order parts.

Parts may also be ordered at:

parts.husmann.com

Call toll free: 1.855.487.7778

Revision History

Revision A: November 2018: Original Issue

Revision B: February 2019: Added MicroDS logo

Revision C: April 2019: Added 6ft shelf data, updated BTU/HR and GPM

Revision D: June 2019: Updated certification on cover

Revision E: July 2019: Updated parts list, lighting, CaseShieldPTM, refrigeration data and wiring diagrams.

Revision F: August 2020: Removed optional rail lights; updated electrical information and wiring diagrams.

Revision G: October 2020: Updated water supply conditions.

Revision H: May 2021: Updated estimated charge and wiring diagram.

Revision J: April 2022: Updated performance data, electrical data and wiring diagrams.

Revision K: November 2023: Updated fan and lighting information.

Revision L: October 2024: Updated cover page